

# All-Electric Ship Design: From Electrical Propulsion to Integrated Electrical and Electronic Power Systems

Giorgio Sulligoi, *Senior Member, IEEE*, Andrea Vicenzutti, *Student Member, IEEE*,  
 and Roberto Menis, *Member, IEEE*

**Abstract**—Electrical propulsion is not a novel concept in marine systems. However, the availability of power electronic converters has proved to be the Key Enabling Technology for electrification of large ships. This paper starts with a summary of EP drives, which led to the birth of all-electric ships. Electric power generation and control systems are then presented, which make it possible to exploit the integrated electrical power system. To ease comprehension of the issues in designing such a system, its conventional design process is given. Then, the reasons that are pushing ahead the research in the shipboard power systems sector are discussed. The need for research in the design methods area is demonstrated through an overview of the latest results of technological research. Finally, a summary of the most significant results on the design tools research is given, including early stage design, dependable-oriented design, and the improvements achievable through software simulators and hardware-in-the-loop are discussed. The goal of this paper is to demonstrate why research on design methods is as important as a technological one, on the basis of the needs concerning the design, integration, and management of future “integrated electrical and electronic power systems” (power systems with power conversion quota approaching 100%).

**Index Terms**—All-electric ships (AESs), design tools, electric power generation and control, electric propulsion, hardware-in-the-loop (HIL), integrated electrical and electronic power systems (IEEPSs), ship design, shipboard power systems, simulator, technological research.

## I. INTRODUCTION

GENERALLY speaking, the mission of a ship is to maximize the quota of payload and to minimize the acquisition and operating costs for the shipowner. Besides this, the history of marine constructions is recurrently pervaded by the intervention of Key Enabling Technologies (KETs). A proof of this regards the transition from the employment of steam engines to reciprocating engines in propulsion and power generation systems onboard. This transition, which happened around the middle of the 20th century, has made it possible to reduce internal spaces dedicated to engines, on the one hand, and to improve efficiency and reliability on the other. Later in the 20th century (around 1990), another

Manuscript accepted July 24, 2016.

The authors are with the Department of Engineering and Architecture, University of Trieste, 34127 Trieste, Italy (e-mail: gsulligoi@units.it; avicenzutti@units.it; menis@units.it).

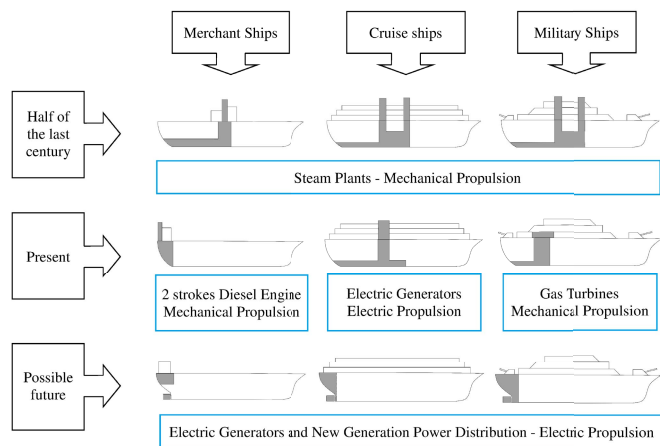

Fig. 1. Ship configuration [2].

relevant example has been given by cruise liners, for which a massive introduction of electric technologies has made it possible to install new large electric propulsion (EP) drives. The availability for marine systems of new electric technologies, coming from different industrial fields (steel industry, rolling mills, railways, petroleum and chemical plants, and so on), was made possible by the developments brought, in those years, by power electronics. The introduction of power electronic devices and converters has made it possible to redesign the whole architecture of shipboard power generation, distribution, and utilization, completely from scratch. This fact has brought relevant changes in the entire ship design, allowing room saving, fuel efficiency, and increased flexibility without impairing reliability, so that, nowadays, 100% of new-built cruise liners are electrically propelled (and many older ships have been already retrofitted in the same way) [1]. In this way, large cruise liners have become all-electric ships (AESs), in the sense that onboard, thermal engines (diesel and/or gas turbines) are used exclusively as prime movers of the synchronous generators. Such an evolutionary process is shown in Fig. 1 in an extremely simplified form [2], while an example of the most salient characteristics of a new-built large all-electric cruise liner is given in Table I. AESs are endowed with a power station that generates the electrical power that feeds all shipboard loads (propulsion, hotel, and auxiliaries) through the so-called

TABLE I  
ALL-ELECTRIC CRUISE SHIP (FINCANTIERI ROYAL PRINCESS),  
MOST SALIENT CHARACTERISTICS

Gross tonnage [GRT]	142.000
Life Saving Appliances	Up to 5600 people
Passenger Cabins	1780
Public areas [sqm]	40000
Length overall [m]	330
Breadth at Waterline [m]	38,4
Maximum Draft [m]	8,55
Contractual Service Speed [knots]	22
Propulsion system	4 LCI converters (48 pulse reaction) on two propellers
Continuous Propellers Output [MW]	2 x 18
Main Generators output [MW]	2 x 21 + 2 x 18
Main switchboards voltage [kV]	11
Total aggregated cable length [km]	4000
Total aggregated cableways length [km]	65
Secondary distribution switchboards	460
Installed circuit breakers	23000

integrated electrical power system (IEPS). In AESs, the power grid results weak, in the sense that, besides being islanded, there are single loads or single generators whose rated power is of the same order of magnitude as the total installed power.

Due to this, assuring the quality of service (QoS) [3] is more difficult in an AES than in land power grids. In fact, on the one hand, the likelihood and magnitude of perturbations are greater, on the other the requirements are more severe, due to both reliability and safety targets imposed by rules and regulations (stated by the International Maritime Organization and the classification societies). Besides cruise liners and other passenger vessels (ferries), a similar evolution happened for other classes of ships as offshore vessels (supply vessels, drillers, platforms, pipe-/cable-layers), icebreakers, mega yachts, and naval vessels. In this paper, after a brief examination of current EP systems (Section II), electric power generation and control systems are discussed in Section III. In particular, their peculiarities are shown, followed by an overview of both their state of the art and their conventional design methodology. The section is concluded with a discussion of the reasons that are pushing ahead the research in the shipboard power systems sector. Then, in Section IV an overview of the latest results of the technological research in this area is given, to explain the need for pushing forward the research in the area of systems design methodologies. Finally, Section V summarizes the most significant results of the research currently in progress on innovative tools for AESs design, ranging from early stage design tools to dependable-oriented design, without forgetting the contribution that can be given by simulators and hardware-in-the-loop (HIL) tests.

## II. ELECTRIC PROPULSION SYSTEM

EP systems are created by installing one or more electrical drives for each propeller. EP motors functionally replace the conventional slow-running diesel propulsion motors (or geared gas turbines), and are fed through power electronic converters. Moving some considerations from the cruise liner case (Fig. 2), which have marked a demarcation line in the sizing of such converters, the order of magnitude is about 15–20 MW per single propeller. Normally, all electric cruise liners are



Fig. 2. Typical cruise ship: Fincantieri Royal Princess.

equipped with two propellers (so a total of 30–40 MW), with some exceptions (remarkable is the record-case of Queen Mary II, equipped with four propellers and a total installed propulsion power of about 86 MW). Electrical propulsion brings a series of well-proven advantages both to the marine architect and to the shipowner:

- 1) superior dynamics (start, arrest, speed variation) offered by electric motors over the conventional diesel motors (or gas turbines);
- 2) possibility of accommodating electrical motors with more flexibility, installing shorter shaft lines, or even outer rotating pods (thus eliminating the rudder and improving maneuverability);
- 3) reduced fuel consumption due to the modulation of thermal engines running (the number of generators on duty is adjusted in order to keep them working at their minimum specific fuel oil consumption);
- 4) higher comfort due to vibration reduction (thermal engines run at constant speed, therefore vibrations filtering is much efficient);
- 5) high level of automation of the engine rooms and related reduced technical crew manning.

The largest propulsion drives commonly use synchronous motors. Historical, reliability, and efficiency reasons are related to such a choice. Among these reasons, not least is the fact that the largest power electronics converters available for marine EP have been, for many years, load commutated inverters. Large power applications, as in cruise liners, can also be achieved through multiphase motors (with related increase in converter numbers). Speed bandwidth requirements of the propeller are completely negligible with respect to even electromechanic transients, therefore a conventional V/Hz speed control is normally implemented. A different solution, still employing thyristor bridges, is the use of cycloconverters, making it possible to generate high torque values at almost zero speed. In the last 10 years, more conventional pulsewidth modulation voltage-source converters have become mature for propulsion system applications, so that the employment of both conventional and advanced motor types has begun (e.g., induction motors and permanent magnet synchronous motors). Diode front ends or active front ends (AFE) can be used on the network side in this case. Some high-performance applications (mainly naval vessels, such as FREMM frigates) already employ AFEs, thus being able to exploit the bidirectional power flow from and to propulsion systems (allowing regenerative braking operation), and improving the IEPS power quality (both by reducing the current harmonics injected during operation and by acting as active filters if needed). It is worth to emphasize that induction motors, after the experiences in the last one/two decades with large power high-voltage (HV) electric drives, are starting to be used

for marine propulsion, especially when high-torque density and shock resistance are required (e.g., in Royal Navy’s Type 45 vessels and U.S. Navy DDG-1000 series). In this case, both acquisition and maintenance costs are expected to reduce (in particular due to the absence of excitation systems and related auxiliaries and control systems).

### III. SHIPBOARD ELECTRIC POWER GENERATION AND CONTROL

#### A. Specific Properties of Power Systems Onboard AESs

The power system onboard AESs must satisfy requirements that are different from the conventional ones (where “conventional” refers to both land power systems and mechanically propelled ship systems). A first difference regards the distinction between essential and nonessential users. Essential users are loads whose supply and correct service must be assured, also in the case of a major system fault (defined by rules and regulations), as their functionalities are essential for the ship’s safe operation. These traditionally include propulsion systems, rudder motors, thruster system, fire suppression systems, communication systems, emergency lights, and navigation systems. Nowadays, also air conditioning, ventilation, toilets, and sanitization systems are starting to be considered as significant services in some classes of ships (e.g., in cruise ships following safe return to port regulation, such systems have to be considered essential in certain areas, called safe areas). In fact, although they are not essential, they assure the onboard living standards. A second aspect regards the absence of an infinite power bus onboard a ship (the IEPS is a weak system). Therefore, the insertion or disconnection of both large loads and generators can result in electromechanic perturbations, larger in magnitude and longer in recovery times in comparison with the conventional power grids (i.e., the EP can absorb more than 50% of the total installed power, therefore strongly affecting the IEPS management, both in steady state and during transients). According to these premises, the IEPS design requires a strong systemic approach, with a particular attention to the functional integration of the different subsystems. Conventional power plants knowledge is not enough, because the IEPS of a large AES includes almost all the possible electrical engineering subsystems: a large power station with generators working in HV (intended as voltage above 1 kV in shipboard applications); a main HV distribution system; a secondary distribution system working in low voltage (LV); almost each kind of electrical machinery used in industrial applications (both in HV and LV, either direct-on-line or supplied by a variable-speed drive). A modern IEPS exploits also an extended use of power electronics, real-time control systems (lower automation layers), and distributed automation systems (higher automation layers), each built and installed by different suppliers, which have to be fully integrated, representing the core of the so-called power management system. In a word that on land would be defined as a “microgrid,” the large power levels and the degree of ICT applications dedicated to power control make the AESs’ IEPS a natural-born multi-megawatt smart grid. Therefore, its design requires the application of the best practices available,

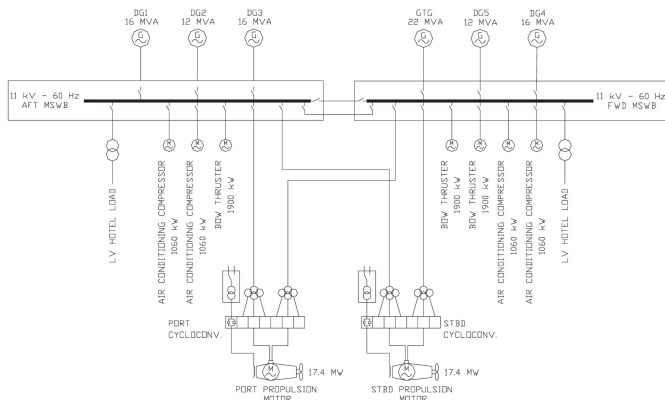

Fig. 3. Common cruise AES IEPS (simplified) [4].

also because no series production is foreseen: each ship is different, so each time a different, fully customized IEPS has to be designed. Finally, it has to be remarked that in an AES, almost all the loads are powered by the IEPS, making it a system with high levels of QoS requirements. In fact, it is clear that a total blackout must be avoided at any case, because it results in both the total loss of the ship’s maneuverability and in the loss of the life support systems. Due to this, the electrical engineer acts not only as a traditional plant designer, but also as a real system integrator, of both the IEPS’s electromechanic and the ICT components.

#### B. Electric Power Generation and Control: State of the Art

As abovementioned, the IEPS is required to provide the capabilities of power generation, distribution, and control to feed all the shipboard loads. In order to comply with such requirements, an IEPS is equipped with a main onboard power station that accommodates the main generators (i.e., all generators except emergency ones). The main generators are directly connected to the main switchboard (HV for large power applications, LV for low power ones), which feeds all the shipboard loads (Fig. 3). Common HV loads are the EP (through propulsion transformers and converters), heating, ventilation and air conditioning (HVAC) system compressors, and thrusters (conventionally direct-on-line asynchronous motors), while all the remaining users (hotel loads, electronics, communications, entertainment, galleys, engine rooms, auxiliaries, etc.) are usually supplied by LV switchboards.

The IEPS is the main system on an AES, and the power station is its “core.” Generating sets are built using synchronous generators that are run at constant speed (corresponding to 60 or 50 Hz, according to U.S. or EU frequency standards) by their prime movers. The latter are normally diesel engines, while high power density applications (or even low emission requirements) call for gas turbines installation. Fig. 3 shows the one-line diagram of the HV section of the IEPS of an all-electric cruise liner, in a peculiar case in which a mix of prime movers have been installed (5 diesel engines, DG1÷5, and 1 gas turbine, GTG). The power station is divided into two sections (AFT and FWD), as well as the main switchboard, and the alternators are connected to the switchboards without the use of transformers. Frequency is regulated through prime movers’ speed governors (SGs),

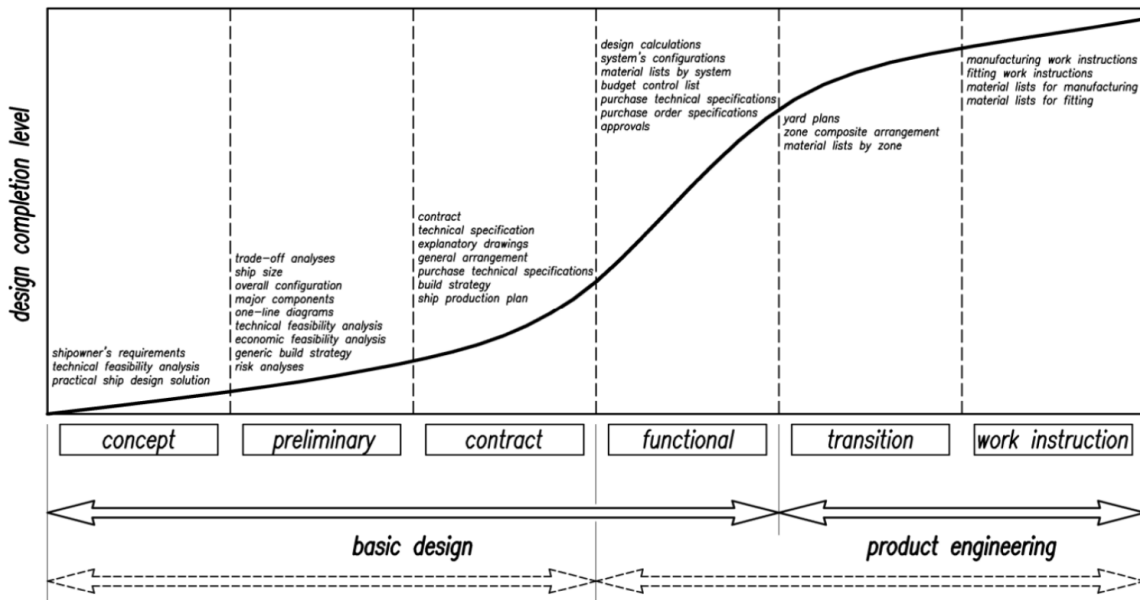

Fig. 4. Ship design process [14].

while the alternators' automatic voltage regulators (AVRs) control voltage (in droop mode) [5]. On some ships, a further AVR is used as a Master, which has the task of eliminating the bus voltage error at steady state due to droop mode regulation. Both SGs and AVRs are real-time control systems, whose choice and tuning is fundamental for the regulation of the shipboard grid electromechanic quantities (frequency, voltage). Their control action is critical during given perturbations, such as in the case of transients due to EP power variations, starting of large induction motors (compressors, thrusters), connection/disconnection of harmonic filters, sudden disconnections of generators, network faults, and reconfigurations. System integration is critical: weaknesses in the design, from this point of view, can bring power quality problems, degradation of the electric service, perturbations, outages, and even the generalized blackout [5], [6].

It should be noted that all IEPS components/subsystems are often designed, built, tested/accepted in factories, then installed and commissioned by different companies, according to the acquisition order prepared by the shipyard. The only real moment for a whole system commissioning is during sea trials (STs), where possible problems are hard to fix (and costly). For this reason, in some classes of ships (such as naval vessels and offshore units), tests using software simulators or even HIL testbeds are requested by the shipowners [7]–[9] and/or by rules [10]. From the QoS point of view, in an IEPS the crucial point is to keep well-regulated both frequency and voltage at the main switchboard. If this is accomplished, then all the remaining sections of the power system are expected to operate correctly. AVRs are the control systems belonging to the electrical engineer's competence, being also the ones involved in the fastest dynamics (excluding protections intervention). The typical assumption is to achieve voltage control by using a set of independent/standalone AVRs. However, the IEPS has to be considered as a single complex system, exploiting a multiple-input-multiple-output architecture.

Due to this, the independent voltage control loops of the AVRs are in fact interacting each other, requiring droop mode regulation in order to achieve stable parallel operation in the steady-state condition. During transients, no control action is foreseen as regards possible dynamic interactions between parallel control loops. It has been shown that, in the case of asymmetrical perturbations, cross-coupled dynamics can arise (even uncontrolled) leading to possible harmful conditions [11]. Another very specific issue regarding IEPS control systems interaction is the possible underdamping of electromechanic oscillations between paralleled generators. This situation has been studied in [12], in the case of a naval vessel in which high-bandwidth SGs were employed. In such a case, frequency and voltage control bandwidth resulted not dynamically decoupled (as usually happens in conventional power systems), leading to underdamped electromechanical oscillations (which can possibly lead to instability and consequent blackout due to protections intervention). Besides conventionally employing radial distribution, in some very specific cases, IEPS with ring bus distribution have been built and are currently operated [13]. However, the abovementioned discussion remains valid. In addition to their core function, auxiliary functions can be implemented in the AVRs, such as redundancy (dual-channel regulators), and diagnostic and data-logging functions (useful to analyze fault events *a posteriori*). Moreover, a certain degree of adaptive control functions should be specified as well, as ship grid configurations change during operations (in both normal and fault conditions).

### C. All Electric Ship Design

The peculiarities of AES's design are related to EP and IEPS design phases, while the rest of the ship design can be considered similar to mechanical propelled ones. Due to this, it is possible to define a series of generic design phases, aimed at obtaining a complete ship from the initial design requirements (Fig. 4) [14]. The IEPS design overlaps different phases,

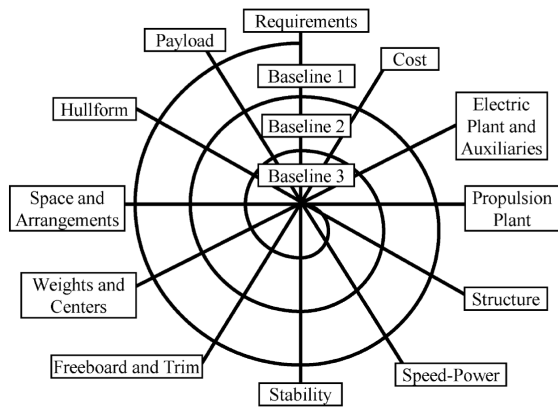

Fig. 5. Spiral ship design process [15].

starting from concept design (where the possible layouts and solutions of the onboard IEPS are conceived) up to the functional design (where the single IEPS components to be acquired by the shipyard are defined). Throughout these phases, the IEPS design proceeds as a partially independent activity. However, such an activity retains interrelations with the others, thus being necessary to consider the overall ship design during its definition. Indeed, due to the peculiar constraints of ships, each subsystem is both significant for operation and in competition with the others in terms of space and weight (dedicating more space to a subsystem implies reducing the available space for another one). Due to this, a balance between costs, space occupied, and achievable performance has to be reached, at the same time assuring the compliancy with requirements. As a result, each subsystem's design process is correlated to the others and the optimal solution is not apparent, making it difficult to correctly design the IEPS without considering the whole ship design. Moreover, in complex systems the overall optimal design solution is rarely the composition of the optimal solutions of the sub-design processes, making it necessary to develop a design methodology that is able to balance the IEPS design with the other subsystems. Several design methodologies can be found in the literature [15]–[21], but the most relevant three are the design spiral, the collaborative concurrent design, and the design space exploration. Among these, the simplest one is the former, which implies performing sequentially all the design activities moving from the most general detail level (achieved during concept design) to more detailed design levels (Fig. 5). Doing this, information resulting from previous design cycles can be used to revise the current iteration, developing more detail at each round and improving the design [15]. In the spiral ship design process in Fig. 5, no reference is made to the IEPS design, because it has been generalized to being applicable to the design of each kind of ship. However, when considering an AES, the IEPS design can be included in the two steps “Propulsion Plant” and “Electric Plant and Auxiliaries,” together with the definition of all power system subsystems. Therefore, it is important to briefly analyze the IEPS design subprocess in order to understand how a system of such an importance is conceived. Similar to what

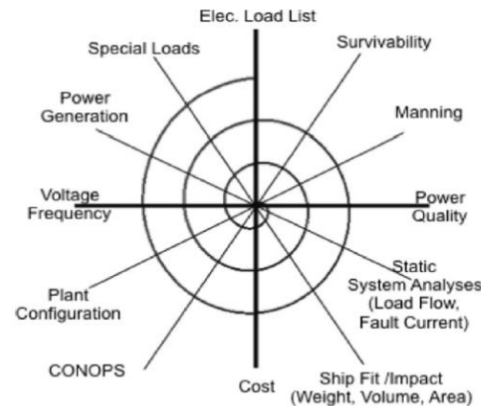

Fig. 6. IEPS design spiral process [22].

happens for the overall ship design, also the IEPS design can be done applying different methodologies, starting from the simple spiral design to complex automated optimization processes.

An explanation of how IEPS design is achieved can be found in [22], while here, some considerations about the relevant steps are made referring to the traditional IEPS design spiral process shown in Fig. 6. The design process begins with the estimation of the so-called “electric loads balance,” which is a list of all the electric loads to be installed onboard. Their power is weighted using appropriate load factors, to account for both the ship's operating and environmental conditions. The result is a matrix depicting the expected amount of electric load to be supplied by generators for each possible ship's operative and environmental conditions, propulsion included. Electric load balance is then used, along with other impacting requirements (such as classification societies regulations), to define rating and the number of generators to be installed onboard. Commonly, these two parameters are selected trying to achieve the maximum efficiency in all the operative conditions of the ship, while maintaining compliance with the requirements. Obviously, installation costs and occupied onboard space have to be taken into account as well, and have to be reduced as much as possible.

The total electric power generation capability installed onboard drives the main bus voltage selection, while frequency is usually defined by the ship's area of operation. Voltage is kept as low as possible to limit the electric machines costs and volumes (which depends on the insulation level), while keeping the fault current levels within the limits of commercially available protection devices. The selection of the plant configuration is the following step, which is the design of the power system to be installed onboard. Such a design has to take into account requirements from rules and regulations, applicable laws, and owner's needs. Due to this, the IEPS architecture generally is chosen between some configurations already validated in the past, depending on the scope of the vessel to be built. This is done in order to decrease the design effort. In this regard, it has to be remarked that complex distribution systems are applied only when the eventuality of a blackout (due to internal or external causes) is to be avoided as much as possible (such as in naval

vessels or dynamic positioned ships). Otherwise, simple radial configurations are preferably used. Apart from the presence of high-power propulsion converters and generators, the IEPS detailed design is similar to the industrial power plants design, therefore little attention will be given to it in this paper. After the power system's design, other activities are done depending on the ship's scope of work. The activities dedicated to cost and ship fit impact evaluations allows assessing the impact of the designed IEPS, respectively, on the project budget and on the rest of the ship. Results from these activities are used to adapt the ship to the designed power system if possible, or to start a redesign activity if the results are not compliant with the constraints and/or the requirements. When an acceptable compromise is achieved, the IEPS design can be considered concluded. However, other activities are done beyond such a step. A concise but complete overview of common studies and analyses performed on the onboard electrical system can be found in [23]. Such analyses are mainly used as verification and to obtain data used to set system control systems and protections, thus being not used to achieve results able to aid in designing the IEPS. This happens because the power system design is done already taking into account the expected results of these analyses (thanks to the experience given by prior IEPS designs), so failing in meeting the required results that commonly happen only in the case of a totally wrong design. Obviously, a failure in meeting one or more requirements can happen in the real world, but if the design is well done, the analysis results are only slightly outside the imposed limits and the issue can be solved with limited effort.

#### *D. Need for Innovation in Shipboard Power Systems Sector*

Modern shipboard IEPSs are complex systems, whose design and management are difficult tasks. Such complexity comes from the need to comply with the strict requirements modern vessels have, on both the system performance level and QoS. Moreover, special applications, such as naval or dynamic positioning (DP) vessels, have ever-higher requirements than common commercial ships, leading to an increase in both overall system's complexity and technology level of installed subsystems. In fact, the QoS can be considered as a new design driver, recently added to the conventional ones that include: 1) reduction of volumes/weights; 2) efficiency improvement; 3) maximization of payload; and 4) cost reduction. Most of the complexity of modern IEPSs comes from such a driver, whose impact on the power system structure and layout (and on the other drivers) is significant. The struggle to reach ever-higher performance levels for the common design drivers, which is pushed forward by owners, and to comply with the QoS requirement set by classification societies and regulations (in commercial sector) or by the client (in the military sector), is leading to fervid research activity on marine power systems. Indeed, in both the commercial and military sectors, a large amount of competitors are present, whose commitment to overcome the others is significant. Nowadays, commercial vessels with low technology content can be designed and constructed by almost every shipyard across the world, making it difficult to overcome the competitors relying solely on the vessel building cost. Conversely, on the military side,

the power play is now based on the units' technological supremacy. Due to this, it is evident that the competition in both the commercial and military sectors imposes to change the current IEPSs in order to keep the leading position. As previously mentioned, research in the shipboard power systems area is fervid, mostly regarding technological aspects. In fact, the U.S. Navy, whose funding commitment is the largest among all the western navies, mainly drives such a research. Research topics promoted by the navies have a broad spectrum, covering almost each aspect of shipbuilding, while in the commercial area, technological research is mainly dedicated to efficiency and cost reduction. The technological research in course is leading toward a shift from the IEPSs to integrated electrical and electronic power systems (IEEPS) concepts. Indeed, the only way to achieve the required improvements in design drivers seems to be the pervasive adoption of power electronics, being integrated in single innovative subsystems to be installed onboard conventional designed vessels [such as energy storage systems (ESSs) to be integrated to improve the overall efficiency], or being used to deploy a completely new power system architecture [such as the novel medium voltage direct current (MVDC) distribution]. However, in order to exploit the maximum possible advantages from the results of technological research, another kind of research activity has to be done, focused on the design activity. In fact, research on design methods is significant, for both conventional and innovative power systems. This is because such a research allows not only defining design procedures able to optimize the system, but also integrating the results of technological research in such a way to as exploit their maximum possible benefits. Due to this, it can be affirmed that research on design methods is as important as the technological research, and can lead to significant improvements in both vessels' capital expenditure (CAPEX) and operational expenditure (OPEX). Finally, it has to be remarked that the entry into force of the safe return to port regulation [24], applicable to passenger ships, is a major concern for ship designers. In fact, such regulation implies the need for redesigning the overall ship arrangements, power system included, in order to achieve the required safety levels. The regulation sets some basic requirements, but lets the designer free to define an alternative design, provided that such a design meets the same intent of the regulation's requirements and provide an equivalent level of safety. In this regard, research on new design methods and tools is relevant, as it allows not only proving the correctness of a new design with respect to rules and requirements, but also lowering the effort required to achieve the correct design.

## IV. TECHNOLOGICAL RESEARCH IN SHIPBOARD POWER SYSTEMS AREA

### *A. Innovative Distribution Systems*

In recent times, the most advanced navies in the world are adopting the AES concept for their new vessels through the installation of HV alternating current IEEPSs. To successfully design such ships, navy designers have drawn largely from the knowledge gained in the merchant field. Due to this,

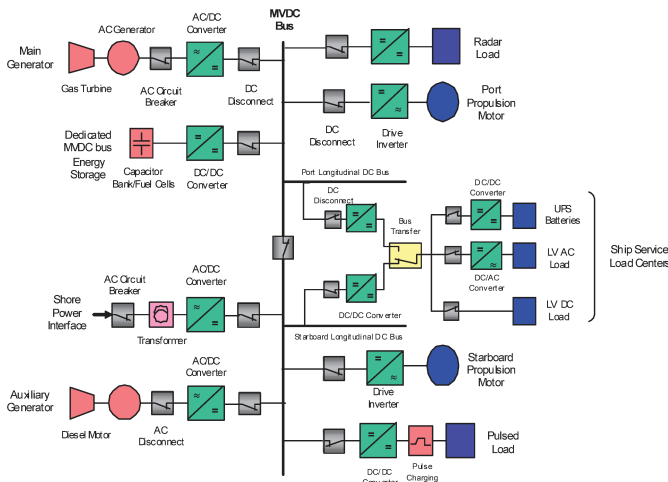

Fig. 7. MVDC radial distribution [25].

in such ships the design effort has been put mainly on achieving high levels of reliability and to improve mission capabilities, starting from a well-known design base. Examples of the most recent naval vessels built using AES concept are the U.K. Navy Type 45 series and the aircraft carrier HMS Queen Elizabeth. Moreover, the increasing use of hybrid propulsion (achieved through a combination of both mechanical and electrical propulsion systems) in lieu of a purely mechanical one is foreseen by most navies, exploiting their interest in the AES concept. However, the current adoption of HV ac IEPS is only a starting point for navies, because the struggle in achieving ever-higher performance is pushing the research on ship's power systems toward new concepts, such as the MVDC distribution system (here the term medium voltage is taken from land standard, as it is done in the IEEE Std. 1709, thus referring to voltages in the range of 1–35 kV). A notional MVDC power system with a radial architecture is shown in Fig. 7, taken from the IEEE Std. 1709 [25]. The interest in MVDC technology is major, due to the advantages that it can give to shipboard power systems (significant mainly for naval vessels, but commercial applications are promising as well). Yet, some relevant issues are still present, whose solving requires both academic and industrial research effort. The pros and cons of dc distribution are well known, and are summarized in [25], and thus will not be repeated here.

Most of the MVDC distribution advantages are related to the high amount of electronic power conversion systems needed in dc power systems to allow their proper operation. However, such a pervasive electronic power conversion presence leads to the main technical issue of MVDC power systems: the constant power loads voltage instability issue. Several research activities are aimed at solving such issues, applying different approaches [4]. In addition, MVDC systems present other relevant issues, which need to be solved prior to their common adoption as onboard systems. Among them, one of the most significant obstacles to the adoption of such power systems is the lack of an established industrial base, being MVDC systems an insignificant commercial market nowadays. In fact, the absence of industrial partners able to supply validated and derisked MVDC components leads designers to generally

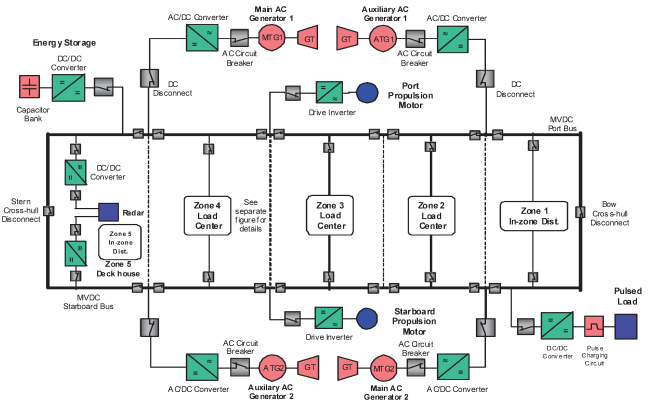

Fig. 8. MVDC zonal distribution [25].

ignore such a solution for onboard distribution, which in turn discourages suppliers' investments in this sector. Luckily, nowadays some major power component suppliers are starting to invest in industrial research related to MVDC application, with the aim of opening new business opportunities [26]. Besides conventional radial distribution, which is the standard in shipboard applications, and ring distribution, which is scarcely used onboard ships (dynamic positioned vessels have a ring power distribution in order to achieve high reconfigurability, but are commonly operated with open buses), another distribution topology that has emerged recently is the zonal distribution. Zonal electrical distribution systems (ZEDSs) are conceived to maximize the QoS, ensuring at least two different and independent power supply inputs for each load. In fact, IEEE Std. 1709 depicts also a zonal version of its notional MVDC power system, shown in Fig. 8. In this regard, IEEE Std. 1826 [27] collects the standard practice for power electronics open system interfaces in ZEDS, and it is the baseline on which such systems have to be designed. ZEDS imply an extended use of power conversion in order to achieve its expected advantages [27]. Due to this, issues such as Constant Power Load (CPL) voltage instability may happen (both in ac [28] and dc sections [4]). Moreover, the major advantage of a zonal architecture (which is the possibility to have several different power sources, ESSs, and power supply paths) is also its main disadvantage. Indeed, such a degree of freedom implies an inherent difficulty in defining the optimal configuration of the system. To allow achieving the most from ZEDS, a complex automation system is required, able to continuously monitor the system and perform optimization algorithms to dynamically set the optimal configuration (the definition of "optimal" depends on the requirements of the system: may be efficiency, or resiliency to faults, or both). Although being the most researched topic on shipboard power systems' technological research area, shipboard MVDC distribution system is yet to be installed onboard a ship (though several land-based demonstrators have been built worldwide and are currently used for the derisking of such a technology). A less complex but still innovative technology is the use of the LV direct current (LVDC) for the secondary power distribution, coupled with a conventional HV ac main distribution system. Such a solution allows achieving some of the advantages of the

TABLE II  
HYPOTHETICAL SPECIFICATION OF INNOVATIVE  
HIGH-POWER WEAPON SYSTEMS [32]

High Power System	Required Power [MW]	Weight [t]	Occupied Surface [m <sup>2</sup> ]
Radar Area Surveillance	4	70	137
Radar Ballistic Missile Defense Surveillance	17	250	272
Rail Gun	60	152	110
Laser (Medium Power) Point Defense	2	21	12
Laser (High Power) Missile Defence	60	65	297

MVDC distribution, making both the integration of a zonal distribution for the essential loads and attaining a high power quality for sensible loads possible. Indeed, such an architecture enables fast reconfiguration actions, high power quality, active control of power flow, and easy integration of ESSs. This in turn allows achieving the advantages of both the dc systems and the zonal distribution architecture, mainly for the loads that will most benefit from them. At the same time, hybrid distribution lowers the requirements for the dc section, making it possible to build a fully operational system already with the current technology. In fact, a ship endowed with such a distribution system has been built: the U.S. Navy guided missile destroyer USS Zumwalt (DDG-1000) [29]–[31]. However, the LVDC power systems' design can also present unforeseen issues, leading to the need for research in the design methodologies area.

### B. Innovative Components for Shipboard Power Systems

In their vision of the near future, the most advanced navies include new weapon systems and advanced sensors as KETs. In fact, research on these innovative components is in course, and working prototypes are already being tested on selected naval vessels. These new systems not only include different kinds of electric powered weapons (for example, railgun and laser), but also high-power radars and new sensor systems. Despite the great differences in both the scope and operation of these new components, all of them are electric powered. To give an idea of the magnitudes involved with such systems, a list of the main innovative systems being developed, with their estimated characteristics is shown in Table II [32].

These systems have a peculiar feature that distinguishes them from common loads: they are pulsed loads. This means that the continuous power absorption of such systems is relatively reduced, but at regular intervals (for sensors) or when fired (for weapons), such loads have an absorption peak (which reaches the values show in Table II) for a very short time (from a few milliseconds up to some seconds). Due to the peculiarities of IEPs, this behavior stresses the system in such a way as to impair its power quality down to levels below the requirements. Such an issue can be clearly seen in Fig. 9 [33], where it is shown the effect of the operation of a pulsed load on a conventional ac power system. Fig. 9 shows the voltage and frequency transients in a power system when a pulsed active and reactive load is applied (e.g., a thruster). In Fig. 9 is shown a magnification of the voltage transient,

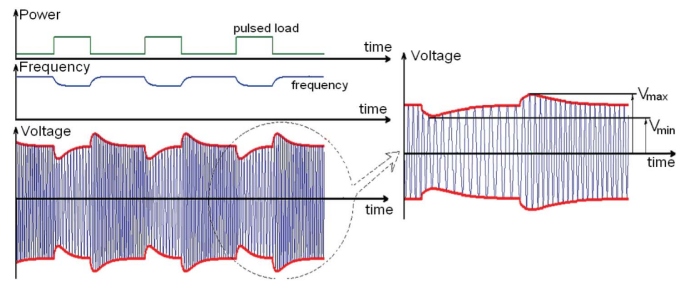

Fig. 9. Impact of a generic pulsed power load on an ac power system [33].

in order to define the maximum amounts of voltage variation due to the pulsed load application, which must not exceed the limits stated from the requirements. Therefore, although being characterized by an amount of energy manageable without problems from the IEPs, these new loads require special considerations in order to be fed without affecting the overall system operation. Studies of pulsed loads in the power system area are mainly addressed at reducing their impact on the IEPs to acceptable levels, exploiting as the most frequently solution the use of power buffers. Such systems, which may be built using several different technologies, are interposed between IEPs and load and supply the electric power required by the pulsed load. Doing this, it is possible to support the absorption peaks using power buffer's internal ESS, while drawing in a constant level of power from the grid. Power buffers decouple the load from the rest of the power system, thus ensuring the maintenance of a proper power quality on the system in spite of the presence of the pulsed load. This solution seems to be the most promising one, and it is capable of providing adequate performance. Therefore, most researchers are focused on this topic.

Besides the pulsed power loads support application, ESSs are a promising technology also for supporting other kinds of onboard operations. Indeed, such systems allow both improving the overall vessel's efficiency and reducing the burden on running generators. Such advantages can be achieved by optimizing the energy flowing in and out of the storage system, absorbing power when low load is applied, and injecting it into the power system when needed. This allows leveling the power variations seen by the generators, thus lowering the burden given by sudden load variations. Moreover, it allows reducing the number of running generators, using stored energy to supply short power peaks or high-power motor startups, thus avoiding starting a generator to support the network in such conditions. As previously stated, the technological research in shipboard power systems area is leading to a shift toward the IEPs concept, thus implying the increase in power converters to be implemented onboard. Until now, the conventional approach in the converters design was to tailor-make the power electronic system in order to adapt it to the single application. This allowed building converters fit for the application but increased the design burden, given the need to design a new converter for each application. A significant result of technological research is the power electronics building blocks (PEBBs) [34], [35]. PEBBs are converter modules with standardized architecture



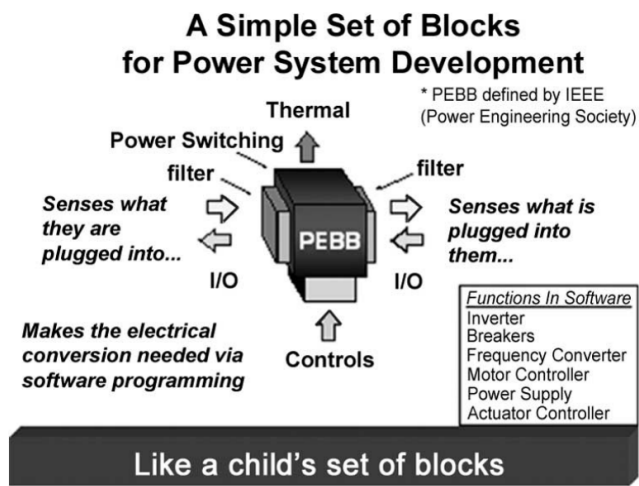

Fig. 10. PEBBs concept [34].

and interfaces, able to exploit different functions by only varying their control software (see Fig. 10) [34]. This allows installing onboard a set of identical converter blocks, and set their functions and mode of operation by programming them into the software. Doing this, it is possible to limit the number of different converters to be installed onboard down to a single topology (the PEBB), declined into a reduced set of different power sizes. Moreover, the PEBB architecture allows adding functions *a posteriori*, making the IEEPS able to integrate new subsystems/components in future.

#### C. Issue of Integrating Technological Research Results in Ship Design

The design of the innovative systems presented above lacks standardization due to their novelty, and the presence of a high number of active components opens the path to unforeseen issues caused by hidden interrelations among them, which cannot be addressed in advance because of the absence of prior knowledge on their operation. Moreover, newly developed subsystems (such as ESSs or PEBBs) are foreseen to be installed in such innovative systems. This leads to the need for design tools and processes that are able not only to infer the impact of the new components on the overall system, but also to help designers in comprehending how such innovative systems are supposed to behave. In fact, the conventional trial-and-error design, commonly applied in ship design [15], [22], performs poorly when such a high level of innovation is to be applied (e.g., the switch from a conventional HV ac IEPS to an MVDC IEEPS). This calls for the need for research on the topic of system design, to complement that on technological aspects. In addition to such an issue, in the marine systems area, the refitting of existing vessels is a common procedure, used to renew old ships (improving both performance and capabilities) and adapt them to the new requirements. Such a process implies the installation of new systems on an already existing vessel, thus requiring an accurate analysis in order to ensure their correct integration into the IEPS. To do this, not only designs and schematics have to be examined, but also the real IEPS of the vessel. In fact, modifications on the power system done *a posteriori*, possible discrepancies

between design data and real data for single components, and components variations due to aging lead to the need for assessing the IEPS state before designing a possible refitting. This can be done through a dedicate measurement campaign, such as that presented in [13]. With the measurement campaign data, it is possible to tailor the interventions to be done on the vessel's IEPS, ensuring the best integration of the innovative system in the existing power system. Design procedures able to correctly address the issues derived from the installation of innovative systems onboard an existing ship are needed, highlighting once again the need for concurrent research in both the technological and design areas.

## V. RESEARCH ON INNOVATIVE TOOLS FOR ALL-ELECTRIC SHIPS DESIGN

### A. AES Early Stage Design

One of the highest concerns in ship design is that the most significant decisions (on system design/architecture) are taken in the early stages of the design process. This is an issue, because in such stages very little information is known about the ship design, thus making it necessary to take decisions on the basis of uncertain data and unconfirmed hypotheses [15]. In the case of the common ship design, the prior knowledge is sufficient in order to correctly guess the correct system design and architecture, making it easy to address the possible errors and discrepancies also in the later design stages. However, innovative power system architectures and innovative components impair such a process. In fact, the design of such systems became complex, because no prior knowledge is present to aid in defining the most suitable design during the early stage design stages. With the aim of addressing such an issue, research on early-stage design is in course [36], [37]. The aims of such a research are to develop methodologies and tools able to infer the impact on the whole ship of the decisions taken during the early stages of the design. Thanks to these, it is possible to try different design solutions (both as IEPS architecture and subsystems arrangements in the ship's hull), evaluating their effect on some selected key performance indicators (KPIs, such as weights, volumes, cost, and reliability). The comparison of the results of such studies allows selecting the design most suitable for the application, even in the case of a completely new system architecture (in the absence of design experience). In this regard, it has to be remarked that the U.S. Navy is financing the research on such topics, with the aim of integrating them into their ship design tools [38]. Indeed, using advanced early stage design techniques it is possible to build vessels endowed with a high amount of innovative technologies. At the same time, it is possible to assure not only a correct design, but also a design that is close to the optimum one, thanks to the opportunity of taking relevant decisions during the early stages of the design with more awareness of their impact on the final result of the design process.

### B. Power System Software Simulators and Hardware-in-the-Loop Testing

The design of modern IEPSs cannot be done without considering the widespread presence of control systems onboard

a ship, whose complexity increases along with the increase in their expected performance and functionalities. The pervasive introduction of power electronic converters has led to an improvement in the control above the system's electrical variables, but it has also increased the number of control systems integrated in an IEPS. Their simultaneous operation makes it necessary to assess both the correct response of the overall system to perturbations and its functional integration (to avoid harmful interactions). Moreover, also protection devices have a relevant impact, because their operation has to be in accordance with the system's controls. In this context, the advancements in power electronic and computer science makes it possible to implement mathematical models in an "easy to use" software environment, exploiting the system's software simulators, and to apply HIL testing before the construction of the system. The former (software simulators) imply the creation of a mathematical model of the system in a computer software, in order to simulate the real system behavior in response to the given conditions/disturbances. The latter (HIL testing) imply the connection of a real control system to a simulated power system, to verify its correct design and the absence of dangerous issues. In such a way, it is possible to assess if the real control system will respond as designed before its installation onboard, thus allowing to solve possible issues when the cost of the needed modifications is still low. Software simulators and HIL tests are commonly used in the technological research area to develop new technologies, but are commonly ignored by system designers. This is a relevant issue, because such tools allow not only to verify the system design correctness and performance before its construction, but also to test events that normally cannot be tested due to the possibility of damaging the real system. In this regard, it is necessary to point out that the use of software simulators and HIL tests for the key systems is imposed also by the new IEC 61892-5 [10], which is in the course of approval. Studies of the subject are already underway, and some evidence of the advantages of HIL testing and simulators in shipboard power systems are already present in the literature [7]–[43]. As aforementioned, such tools are well known in the academic area, so a brief explanation will be given in the following, focusing mostly on the impact they can have on the system design.

### C. Software Simulators

Through a mathematical model of the system, implemented in a software environment, it is possible to evaluate the system's behavior in response to various events, depending on the models chosen for the elements. When considering the IEPS design process, such a software can greatly help during design process, allowing to evaluate the behavior of the system during the design stages, before building the real system. In a system with stringent requirements, such an aid may be essential in order to develop a product able to achieve success on the market. This because it allows: 1) a greater flexibility in design; 2) a simpler and immediate definition of emergency actions; 3) checking correct coordination between protections and control systems; and 4) supporting training; a simpler definition of the control system parameters. Examples of what

can be achieved through the simulation software can be found in the literature, coming from both academic and industrial research [7], [39]. However, in order to achieve the minimum level of accuracy needed to successfully use a simulator, a tuning procedure has to be done, using data coming from common tests performed on the system's components before the delivery of the ship to the customer (factory acceptance tests and STs) [5]. Such a procedure can be done only if the real system has already been built, leading to believe that such a software will be of little use during the design process. This is only partially true, because the tuning allows obtaining a high accuracy in simulation results, but such accuracy may not be needed during design. In fact, even approximated results can be sufficient to guide the designers' decisions during early stage design. Once the system is in the construction phase, the simulator can be tuned, thanks to the data coming gradually from the components tests, allowing to finely tune control systems and define emergency procedures through the software simulator, without the risk of damaging the real system.

### D. HIL Testing

HIL test benches are powerful tools, allowing the derisking of new technologies before their installation on a real full-scale system [40]–[43]. Commonly needing a physical hardware to test, HIL testing should not be considered a part of system design. However, it may be useful as a support tool during the system design, if the proper approach is applied. In fact, HIL testing is commonly applied in prototyping new components/subsystems to demonstrate their applicability in the real environment. Such a practice may take place before system design (during technological research and component/subsystem engineering) or during the later stages of ship design. In the former case, HIL testing of innovative components/subsystems allows determining their behavior when integrated into an IEPS, thus enabling the designers to include them in the system design as a viable alternative to conventional components. In the latter case, innovative components can be tested before their installation onboard, using HIL test to verify the correctness of their design (thus allowing to define and implement any corrective actions required if the requirements are not met).

### E. Dependability Application to IEPS/IEEPS Design

Commonly, shipboard power systems design is done considering drivers such as performance, cost, and rules and regulations compliance. In this regard, the designers tend to rely on solutions and design procedures well proven, since it is the common belief that what works should not be changed. However, the recent happening of significant marine accidents (such as Deep Water Horizon, to name one of the most famous in the past years) highlighted the substantial lack of attention to system's resilience to failures in the system's design process. Besides their bad consequences, these accidents had a positive effect: they brought attention to the consequences of failure on people, properties, and the environment. This happened mostly due to the fact that the final damage cost has proven to be orders of magnitude greater than the cost of the single marine systems involved [44]. These occurrences substantially

changed the point of view of the parties involved in the marine sector, whose interest in the consequences of faults was rather low before. Safe return to port regulation [24] is one example of such an increased interest in safety, defining the guidelines to design marine systems and the expected fault scenarios the system has to tolerate without impairing system's safety. However, the increased interest in system's safety and resilience to failures generates in turn an increase in the design burden, being it necessary to analyze faults and consequences and demonstrate the system's compliancy with the relevant regulations. This highlights the need for a different design process, able to integrate a more comprehensive, systematic, efficient, and widely supported approach for the analysis of the system fault consequences. In this context, an innovative approach given by the dependability theory can be the tool capable of providing this step-ahead, as amply demonstrated in other areas where it is used (e.g., computer science [45]). Indeed, such an approach has a long story, starting from nuclear plants and military telecommunication systems, and has widely proven its usefulness becoming crucial in all safety-critical applications (like aerospace and nuclear energy) [46]. Various approaches to dependability have been developed separately in each technological sector, leading to a lack in both definitions and concepts standardization. This happened because of the interest in the system's response to faults, and related people/equipment/environmental safety, aroused in many different industrial applications separately, leading to several different theories/definitions to analyze and solve the same issues. However, a common approach could be implemented, sharing the conceptual/implementation effort, through a comprehensive and systematic formulation of dependability theory. Indeed, the qualities involved in all the different approaches to dependability separately developed can be integrated into a single theory, as different attributes that contribute to the definition of the overall system's dependability (as shown in Fig. 11) [47].

Along with a separate formulation of the dependability theory, different techniques aimed at studying and improving the dependability of a system have been developed in each industrial application area, such as fault tree analysis [48]–[52], failure modes and effects analysis (FMEA) [52]–[55], and hazard and operability analysis (HAZOP) [56]–[58]. Such techniques can be also integrated together as different methods to attain a similar goal: improve the dependability level of a system (namely “enforcing techniques”). An overview of such a comprehensive formulation of the dependability theory can be found in [47], based on [59] and [60]. It is relevant to notice that some dependability concepts have recently aroused interest also in terrestrial power systems, in particular reliability. Indeed, in such large systems (such as electric power distribution networks), the number of subsystems is so high as to require a systematic approach to maintenance and management, an approach given by the reliability analysis branch of the dependability theory. In this regard, IEEE published the Standard 493 to state the “IEEE Recommended Practice for the Design of Reliable Industrial and Commercial Power Systems” [61]. Nowadays, dependability concepts and techniques are used in several industrial applications.

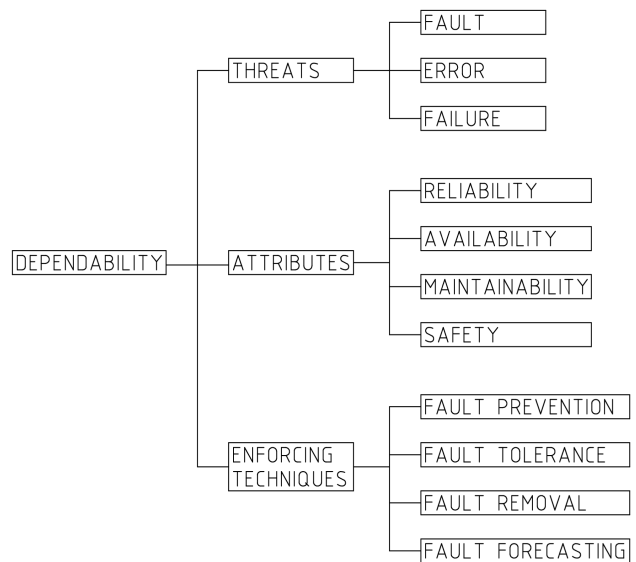

Fig. 11. Dependability overall concepts [47].

Where its application was lacking until recent times is in marine systems. Nevertheless, its use is increasing, promoted by recent severe accidents and by stricter regulations. Some examples of such diffusion can be given, mainly concerning shipboard power systems and related subsystems, but are not limited to these.

#### F. Reliability Centered Maintenance

Maintenance costs are a significant part of the overall operating costs of a ship. The rigid prescriptions from regulatory bodies and the recommendations from equipment suppliers make it appear as an obligation, rather than something positive. Nevertheless, maintenance is essential to keep equipment in the best possible conditions, in turn affecting the system's dependability and thus having both environmental and safety consequences. In this regard, an approach to maintenance focused on reliability can be applied: the reliability centered maintenance (RCM). RCM focuses maintenance resources only on those items that affect the system reliability [62]. In such a way, maintenance can be applied as a cost-effective procedure, ensuring at the same time the best possible operation of equipment from the point of view of the overall ship operation. Such an approach has its origin in aircraft maintenance programs (in particular from the Boeing 747 one), where a conventional maintenance approach would have led to a commercial failure due to excessive maintenance effort. An extensive description of RCM can be found in [62], where all the issues and peculiarities of its shipboard application are analyzed. Although seeming a rather complex approach, some evidences of successful application to ships are present. As an example, the United States Coast Guard recently investigated new maintenance strategies for its assets (in particular diesel engines), highlighting the RCM as the most promising approach [63].

#### G. Use of Dependability Techniques to Verify Marine IEPS/IEEPS

In the marine sector, some applications have more demanding requirements than others, in particular for what concerns

the system behavior in fault conditions. Naval vessels are the most obvious ones, but other units may also have requirements as strict as they may. In particular, faults are to be taken into account in each vessel that is “mission critical,” such as oceanographic vessels, pipe/cable layers, drilling vessels, and so on. In such vessels, failing to comply with the QoS requirements means impairing the mission, or even failing it, with the relevant economic impact and possible harmful consequences to human health, properties, and the environment. Due to this, the issue of system’s dependability emerged also in marine application, similarly to what happened in aerospace and nuclear plant systems. Luckily, solutions were already developed for these applications, so proper concepts and techniques have been brought to the marine sector. In the commercial sector, this “evolution” has been mainly driven by regulatory bodies, which have direct interest in failure consequences and related compensations. In particular, when vessels dedicated to mission critical applications have to be designed and built, regulations impose requirements dedicated specifically to ensure a minimum level of system’s fault resistance. This is done through the definition of rules specifying the behavior of the system following some relevant fault events, such as a generator loss (examples are the American Bureau of Shipping (ABS) Rules and Regulations [64] and [65]). As appears evident, the used approach has a major flaw: it cannot address each possible fault event and failure mode, due to the generalization applied in such rules and regulations. Indeed, it is not possible to create regulations dedicated to each particular system’s design and/or specific application, so a certain amount of generalization has to be applied. In such a process, only the most relevant fault events are retained, leaving the definition of all the possible failure modes of the system to the designer. However, regulatory bodies need an assurance of the proper identification and removal of each possible point of failure. To do that, the solution used by regulations is to require a dependability analysis, commonly in the form of an FMEA (as clearly stated by rule 2/11.1 of ABS Guide on DP systems [65]).

Following regulatory bodies’ specifications, designers can define the preliminary design of the system, which is that able to meet the requirements of the customer and at the same time comply with the regulations requirements. Then an FMEA can be done, at first on preliminary design, and then on detailed design, to assess each possible point of failure for the system. Proper solutions for the critical point emerged from the analysis have to be taken, and the final system FMEA has to be submitted for approval to the regulatory body. Once approved, system can be considered well designed, and ship construction can proceed. Designers can also apply other techniques on their own, to aim at improving the system (one of these is HAZOP technique). However, classification societies require an FMEA, so it is common to rely only on it. This approach has led to a substantial improvement in the mission critical vessels design. An example of such an improvement can be found in [55], where a brief review of the historical evolution that led to the application of FMEAs to dynamic positioned vessels is presented. Nevertheless, the imposition of such an approach by regulatory bodies to designers has led to a

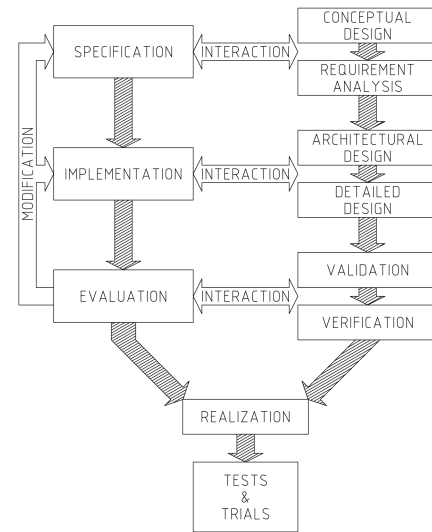

Fig. 12. IEPS/IEEPS dependable-oriented design [69].

relevant issue: both users’ and designers’ perception is that FMEAs must be performed to comply with a requirement. This causes a lack of interest in dependability techniques, which are considered as checks to be marked to build a ship, rather than powerful tools to be used to attain a better design. Conversely, academics and consultants tend to have an approach to dependability more open than users and designers, as demonstrated by several works in the literature, whose goal is to explain the benefits of an approach to the ship’s design more focused on dependability ([66]–[68], only to mention some).

#### H. Dependable-Oriented Design

As aforementioned, dependability techniques can be a relevant aid not only to assess the system behavior in the case of faults, but also to verify the system’s compliance with particular requirements. To this extent, some applications in the marine sector are already present, but a further step can be done: the application of dependability theory to system design. In particular, system design may positively improve through the integration of both qualitative and quantitative techniques. A design process integrating dependability theory approach can be defined as “dependable oriented design.” Dependable-oriented design can be achieved introducing dependability dedicated activities to the common design process (as shown in Fig. 12) [47], [69]. These activities interact with the conventional design ones, in different stages of the process, with the aim of improving it.

- 1) Specification step allows assessing faults that are likely to happen during ship’s operation, starting from conceptual design and contractual requirements. Doing this, it is possible to use the desired system’s behavior (in response to such faults) as an input for design.
- 2) Implementation step allows to pinpoint single subsystems and components menacing the system’s dependability, through a dependability analysis on the chosen system architecture.

3) Evaluation step is used to evaluate if the designed system meets the expectations concerning its behavior in response to fault events.

Issues emerging in these steps can be addressed through a feedback to the designers, to change the design accordingly. The depth of the feedback depends on the extent of the issue to be solved and on the applicable solutions. Such a design process allows pinpointing most of the issues that may lead to a system failure and solve them, depending on the skills of both analysts and designers. In [69], an extended discussion of the advantages of dependable-oriented design is made, together with the motivations that may drive each subject involved in the ship's design (shipyard, subcontractors, classification societies, and owner) to its adoption. Moreover in [68], indications of how integrating dependable-oriented design from a project management point of view is given. The discussion presented in such a reference demonstrates that most of the relevant data needed to apply is already present in the conventional design process. Therefore, it is possible to implement dependable-oriented design for ships' IEPSs/IEEPSs with a limited effort on management. Although dependable-oriented design seems an innovative application, nowadays it is already applied in mission critical systems, even if not in such a systematic way. Indeed, in such applications a series of qualitative analysis (usually FMEAs or HAZOP analyses) made throughout all the system design process are used as a means to highlight hazards and critical issues. Such an approach is the basis of dependability-oriented design, and it demonstrated to be successful in real applications, although resource consuming.

## VI. CONCLUSION

The goal of this paper has been to demonstrate why research on design methods is as important as the technological one, on the basis of the needs concerning the design, integration, and management of future "IEEPS" (power systems with power conversion quota approaching 100%). This paper has shown at first the results of the huge revolution in ship design caused by the birth of the AESs. This revolution was mainly due to the need of integrating onboard a major system, such as the IEPS. Starting from these well-known bases, this paper has demonstrated that nowadays the competition in the marine industry sector is pushing toward a change in the conventional shipboard power system paradigms.

First of all, the increasing use of power electronics conversion is leading toward a new revolution in design, due to the shift from the IEPS to the IEEPS concept. Second, the advancements in technological research are making it possible to achieve ever-higher performance and functionalities from the modern shipboard power systems, through the exploitation of new electrical technologies onboard ships. Some of these are so important as to be even considered as KETs, as they allow to achieve significant improvements in respect to the conventional practice, thus enabling to obtain supremacy (military or commercial) over competitors. Such technologies can come from land applications, having been tested and demonstrated only in land power systems, or can have been developed directly for shipboard applications. In the latter case, tests are

mainly done in laboratories, using software simulators, HIL tests, or even on reduced-scale testbeds. However, in order to demonstrate that these promising research results can be applied on real systems and can work as expected, a proof of concept must be made. This can be achieved using full-scale testbeds, in either land facilities or onboard test ships. This paper has presented some of these technologies, with the aim of motivating the need for new design methods and tools.

As a matter of fact, apart from the demonstration of the correct operation of these innovative technologies, another issue that arises due to their introduction in the common practice is the lack of design methods and tools able to take into account such an innovation. Indeed, the price to be paid in order to integrate research results into industrial products is the increase in system design complexity, due to the lack of prior experience of the correct design and integration of new technologies. Due to this, research on design methodologies is significant, and must be done along with the more common technological research. Although well adopted and considered highly valuable in other industrial applications (such as aerospace one), in shipboard power systems area such research is a newcomer. Indeed, the complexity of the modern age requires a renewed design approach in respect to common IEPSs. Techniques and tools dedicated to the early stage design of ship's power systems are being developed, and innovative applications of tools dedicated until now to other applications are being proposed (such as software simulators and HIL testing). The most significant ones have been briefly discussed in this paper. Among them, the dependability theory and techniques are significant, not only in applications with strict safety and fault resilience requirements (e.g., in naval and DP vessels), but also in less mission-critical systems. Due to this, integration of the dependability theory in common design processes is foreseen, in order to promote its application and allow achieving its advantages as much as possible. Besides their aid in designing innovative systems, new design methods and tools can be considered important in the shipbuilding industry also to demonstrate the effectiveness of technology research results integration in real products. In fact, the main proof of concept in the shipbuilding industry is not related to the demonstration of a working technology, but it is mainly related to the advantages it can give to the vessel. Indeed, common KPIs onboard are space, weight, efficiency/performance, and safety. Due to this, an innovative technology is considered for onboard installation only if it allows increasing the KPI, because this in turn means increasing the vessel's payload and reducing both its CAPEX and OPEX.

Given these premises, it is easy to comprehend why research on design methods and tools is so significant for the shipboard systems area. Indeed, they allow not only to correctly integrate onboard innovative technologies, but also to evaluate how much these technologies impact KPI. Doing that, new design methods and tools make it possible to effectively select the correct design for onboard systems. Such an aid becomes more and more relevant as the system's complexity increases, as is currently happening with the evolution from the IEPS to the IEEPS concept. Moreover, ships are commonly a small series product, even unique products in some cases, thus making the

research on design methods and tools even more important than in common land applications.

Finally, it has to be remarked that a lot of new design methods and tools are currently being developed for other applications. This makes it possible to use research results from other technical areas, avoiding rediscovering already known concepts and techniques. In particular, it is possible to highlight the similarities among shipboard power system design and land microgrids, caused by their analogies in structure and functionalities [70]. Due to this, transferring technologies and design methods and tools between these two conventionally well-separated research areas has to be of primary interest to researchers, because it will greatly increase the rate of evolution of both these technical areas.

## REFERENCES

- [1] G. Sulligoi, "All electric ships: Present and future after 20 years of research and technical achievements," *Elect. Eng. Res. Rep.*, vol. 1, no. 27, pp. 28–33, Dec. 2011.
- [2] N. H. Doerry and D. H. Clayton, "Shipboard electrical power quality of service," in *Proc. IEEE Electr. Ship Technol. Symp.*, Philadelphia, PA, USA, Jul. 2005, pp. 274–279.
- [3] D. Bosich, A. Vicenzutti, R. Pelaschiar, R. Menis, and G. Sulligoi, "Toward the future: The MVDC large ship research program," in *Proc. AEIT Annu. Conf. (AEIT)*, Trieste, Italy, Oct. 2015, pp. 1–6.
- [4] M. Cupelli *et al.*, "Power flow control and network stability in an all-electric ship," *Proc. IEEE*, vol. 103, no. 12, pp. 2355–2380, Dec. 2015.
- [5] A. Vicenzutti, D. Bosich, G. Giadrossi, and G. Sulligoi, "The role of voltage controls in modern all-electric ships: Toward the all electric ship," *IEEE Electr. Mag.*, vol. 3, no. 2, pp. 49–65, Jun. 2015.
- [6] I. Jonasson and L. Soder, "Power quality on ships. A questionnaire evaluation concerning island power system," in *Proc. IEEE 9th Int. Conf. Harmon. Quality Power*, Oct. 2000, pp. 639–644.
- [7] G. Sulligoi, D. Bosich, T. Mazzuca, and L. Piva, "The FREMM simulator: A new software tool to study electro-mechanic dynamics of the shipboard integrated power system," in *Proc. Elect. Syst. Aircraft, Railway Ship Propuls. (ESARS)*, Bologna, Italy, Oct. 2012, pp. 1–6.
- [8] L. U. Gokdere, C. W. Brice, and R. A. Dougal, "A virtual test bed for power electronic circuits and electric drive systems," in *Proc. 7th Workshop Comput. Power Electron. (COMPEL)*, Blacksburg, VA, USA, Jul. 2000, pp. 46–51.
- [9] L. U. Gokdere, C. W. Brice, and R. A. Dougal, "Graphical and visual simulation of electric drive systems," in *Proc. Int. Conf. Electr. Mach. Drives (IEMD)*, May 1999, pp. 685–687.
- [10] *Mobile and Fixed Offshore Units—Electrical Installations—Part 5: Mobile Units*, document IEC 61892-5, 2014.
- [11] V. Arcidiacono, R. Menis, and G. Sulligoi, "Improving power quality in all electric ships using a voltage and VAR integrated regulator," in *Proc. IEEE Electr. Ship Technol. Symp. (ESTS)*, Arlington, VA, USA, May 2007, pp. 322–327.
- [12] G. Sulligoi, A. Vicenzutti, M. Chiandone, D. Bosich, and V. Arcidiacono, "Generators electromechanical stability in shipboard grids with symmetrical layout: Dynamic interactions between voltage and frequency controls," in *Proc. AEIT Annu. Conf.*, Mondello, Italy, Oct. 2013, pp. 1–5.
- [13] G. Lipardi *et al.*, "Electric loads characterization in an aircraft carrier with ring-bus distribution system," in *Proc. Int. Conf. Elect. Syst. Aircraft, Railway, Ship Propuls. Road Vehicles (ESARS)*, Aachen, Germany, 2015, pp. 1–6.
- [14] V. Bucci, A. Marinò, and I. Juricic, "Integrated ship design: Automated generation of production deliverables with new generation shipbuilding CAD systems," in *Proc. Conf. Comput. Appl. Inf. Technol. Maritime Ind.*, Hamburg, Germany, Apr. 2013, pp. 1–14.
- [15] J. Chalfant, "Early-stage design for electric ship," *Proc. IEEE*, vol. 103, no. 12, pp. 2252–2266, Dec. 2015.
- [16] P. A. Gale, "The ship design process," in *Ship Design and Construction*, vol. 1, T. Lamb, Ed. Alexandria, VA, USA: Society of Naval Architects and Marine Engineers, 2003, ch. 5.
- [17] F. Mistree, W. F. Smith, B. Bras, J. K. Allen, and D. Muster, "Decision-based design: A contemporary paradigm for ship design," *Trans.-Soc. Naval Archit. Marine Eng.*, vol. 98, pp. 565–597, Jan. 1990.
- [18] N. H. Doerry and H. Fireman, "Designing all electric ships," in *Proc. 9th Int. Marine Design Conf.*, Ann Arbor, MI, USA, May 2006, pp. 475–497.
- [19] A. Brown and J. Salcedo, "Multiple-objective optimization in naval ship design," *Naval Eng. J.*, vol. 115, no. 4, pp. 49–61, Oct. 2003.
- [20] J. Stepanchick and A. Brown, "Revisiting DDGX/DDG-51 concept exploration," *Naval Eng. J.*, vol. 119, no. 3, pp. 67–88, Nov. 2007.
- [21] H. Ali *et al.*, "Cross-platform validation of notional baseline architecture models of naval electric ship power systems," in *Proc. IEEE Electr. Ship Technol. Symp. (ESTS)*, Alexandria, VA, USA, Apr. 2011, pp. 78–83.
- [22] T. J. McCoy, "Integrated power systems—An outline of requirements and functionalities for ships," *Proc. IEEE*, vol. 103, no. 12, pp. 2276–2284, Dec. 2015.
- [23] J. Warwick, "Electrical systems analysis," in *Proc. Dyn. Positioning Conf.*, Oct. 1997, pp. 1–11.
- [24] *SOLAS: Consolidated Text of the International Convention for the Safety of the Life at Sea—2014 Edition*, Int. Maritime Org., London, U.K., 2014.
- [25] *IEEE Recommended Practice for 1 kV to 35 kV Medium-Voltage DC Power Systems on Ships*, IEEE Standard 1709-2010, Nov. 2010, pp. 1–54.
- [26] G. Sulligoi, A. Tessarolo, V. Benucci, A. M. Trapani, M. Baret, and F. Luise, "Design, implementation and testing of a shipboard medium-voltage DC generation system based on a ultra-high speed 12-phase alternator," in *Proc. IEEE Electr. Ship Technol. Symp.*, Alexandria, VA, USA, Apr. 2011, pp. 388–395.
- [27] *IEEE Standard for Power Electronics Open System Interfaces in Zonal Electrical Distribution Systems Rated Above 100 kW*, IEEE Standard 1826-2012, Jun. 2012, pp. 1–46.
- [28] G. Sulligoi, A. Vicenzutti, V. Arcidiacono, and Y. Khersonsky, "Voltage stability in large marine integrated electrical and electronic power systems," in *Proc. IEEE Petroleum Chem. Ind. Tech. Conf. (PCIC)*, Houston, TX, USA, Oct. 2015, pp. 1–10.
- [29] J. Momoh and L. Mili, *Operation and Control of Electric Energy Processing Systems* (IEEE Press Series on Power Engineering). New York, NY, USA: Wiley, 2010.
- [30] N. Doerry, J. Amy, and C. Krolick, "History and the status of electric ship propulsion, integrated power systems, and future trends in the U.S. Navy," *Proc. IEEE*, vol. 103, no. 12, pp. 2243–2251, Dec. 2015.
- [31] D. Schneider, "Clad in controversy," *IEEE Spectr.*, vol. 50, no. 8, pp. 32–37, Aug. 2013.
- [32] D. Witt, D. Helfers, and Y. L. Young, "Comparative study of power generation and energy storage modules for support of high energy weapons," *Naval Eng. J.*, vol. 124, no. 2, pp. 74–77, Jun. 2012.
- [33] J. M. Prousalidis, P. Mouzakis, E. Sofras, D. Muthumuni, and O. Nayak, "On studying the power supply quality problems due to thruster start-ups," in *Proc. IEEE Electr. Ship Technol. Symp. (ESTS)*, Baltimore, MD, USA, Apr. 2009, pp. 440–448.
- [34] T. Ericson, N. Hingorani, and Y. Khersonsky, "Power electronics and future marine electrical systems," *IEEE Trans. Ind. Appl.*, vol. 42, no. 1, pp. 155–163, Jan. 2006.
- [35] F. Wang, Z. Zhang, T. Ericson, R. Raju, R. Burgos, and D. Boroyevich, "Advances in power conversion and drives for shipboard systems," *Proc. IEEE*, vol. 103, no. 12, pp. 2285–2311, Dec. 2015.
- [36] J. Chalfant, M. Ferrante, and C. Chryssostomidis, "Design of a notional ship for use in the development of early-stage design tools," in *Proc. IEEE Electr. Ship Technol. Symp. (ESTS)*, Alexandria, VA, USA, Jun. 2015, pp. 239–244.
- [37] D. J. Jurkiewicz, J. Chalfant, and C. Chryssostomidis, "Modular IPS machinery arrangement in early-stage naval ship design," in *Proc. IEEE Electr. Ship Technol. Symp. (ESTS)*, Arlington, VA, USA, Apr. 2013, pp. 121–127.
- [38] M. Ferrante, J. Chalfant, C. Chryssostomidis, B. Langland, and R. Dougal, "Adding simulation capability to early-stage ship design," in *Proc. IEEE Electr. Ship Technol. Symp. (ESTS)*, Alexandria, VA, USA, Jun. 2015, pp. 207–212.
- [39] T. Lauvdal, "Optimizing and evaluating the performance of power and thruster plant in DP vessels with an integrated vessel simulator," in *Proc. Dyn. Positioning Conf.*, Oct. 2000, pp. 1–18.
- [40] T. A. Johansen and A. J. Sørensen, "Experiences with HIL simulator testing of power management systems," in *Proc. Dyn. Positioning Conf.*, Oct. 13–14, 2009.
- [41] J. Langston, M. Sloderbeck, M. Steurer, D. Dalessandro, and T. Fikse, "Role of hardware-in-the-loop simulation testing in transitioning new technology to the ship," in *Proc. IEEE Electr. Ship Technol. Symp. (ESTS)*, Arlington, VA, USA, Apr. 2013, pp. 514–519.

- [42] M. Cupelli, M. de Paz Carro, and A. Monti, "Hardware in the loop implementation of a disturbance based control in MVDC grids," in *Proc. IEEE Power Energy Soc. General Meeting*, Jul. 2015, pp. 1–5.
- [43] M. Andrus *et al.*, "Real-time simulation-based design of a power-hardware-in-the-loop setup to support studies of shipboard MVDC issues," in *Proc. IEEE Electr. Ship Technol. Symp. (ESTS)*, Apr. 2009, pp. 142–151.
- [44] J. L. Ramseur, *Deepwater Horizon Oil Spill: Recent Activities and Ongoing Developments*. Washington, DC, USA: Congressional Research Service, Apr. 2015.
- [45] V. P. Nelson, "Fault-tolerant computing: Fundamental concepts," *Computer*, vol. 23, no. 7, pp. 19–25, Jun. 1990.
- [46] N. G. Leveson, *Safeware: System Safety and Computers*. Reading, MA, USA: Addison-Wesley, 1995.
- [47] G. Buja, A. da Rin, R. Menis, and G. Sulligoi, "Dependable design assessment of integrated power systems for all electric ships," in *Proc. Elect. Syst. Aircraft, Railway Ship Propuls. (ESARS)*, Bologna, Italy, 2010, pp. 1–8.
- [48] W. S. Lee, D. L. Grosh, F. A. Tillman, and C. H. Lie, "Fault tree analysis, methods, and applications—A review," *IEEE Trans. Rel.*, vol. R-34, no. 3, pp. 194–203, Aug. 1985.
- [49] Y.-Y. Hong, L.-H. Lee, and H.-H. Cheng, "Reliability assessment of protection system for switchyard using fault-tree analysis," in *Proc. Int. Conf. Power Syst. Technol. (PowerCon)*, Oct. 2006, pp. 1–8.
- [50] *NUREG-0492—Fault Tree Handbook*, U.S. Nucl. Regulatory Commission, Washington, DC, USA, 1981.
- [51] *Fault Tree Analysis (FTA)*, document IEC 61025, 2006.
- [52] R. Menis, A. da Rin, A. Vicenzutti, and G. Sulligoi, "Dependable design of all electric ships integrated power system: Guidelines for system decomposition and analysis," in *Proc. Elect. Syst. Aircraft, Railway Ship Propuls. (ESARS)*, Bologna, Italy, Oct. 2012, pp. 1–6.
- [53] R. Eriksen, J. Harms, and R. McDonnell, "Assessing the reliability of dynamic positioning systems for deepwater drilling vessels," in *Proc. Dyn. Positioning Conf.*, Oct. 1999, pp. 1–12.
- [54] *Guidance on Failure Modes & Effects Analyses (FMEAs) (IMCA M166 Rev 1)*, Int. Marine Contractors Assoc., London, U.K., Apr. 2016.
- [55] H. Shatto and D. Phillips, "Reliability and risk analysis—Failure modes and effects analysis (FMEAs)," in *Proc. Dyn. Positioning Conf.*, Oct. 1997, pp. 1–31.
- [56] F. Crawley and B. Tyler, *HAZOP: Guide to Best Practice—Guidelines to Best Practice for the Process and Chemical Industries*. Amsterdam, The Netherlands: Elsevier, 2015.
- [57] *Hazard and Operability Studies (HAZOP Studies)—Application Guide*, document IEC 61882, 2001.
- [58] A. Munn, "Common problems and recent trends with HAZOPs," in *Proc. IChemE Symp.*, vol. 155, 2009, pp. 1–4.
- [59] M. Al-Kuwaiti, N. Kyriakopoulos, and S. Hussein, "A comparative analysis of network dependability, fault-tolerance, reliability, security, and survivability," *IEEE Commun. Surveys Tuts.*, vol. 11, no. 2, pp. 106–124, 2nd Quart., 2009.
- [60] A. Avizienis, J.-C. Laprie, B. Randell, and C. Landwehr, "Basic concepts and taxonomy of dependable and secure computing," *IEEE Trans. Depend. Sec. Comput.*, vol. 1, no. 1, pp. 11–33, Jan./Mar. 2004.
- [61] *IEEE Recommended Practice for the Design of Reliable Industrial and Commercial Power Systems*, IEEE Standard 493-2007, Jun. 2007, pp. 1–689.
- [62] A. J. Mokashi, J. Wang, and A. K. Verma, "A study of reliability-centred maintenance in maritime operations," *Marine Policy*, vol. 26, no. 5, pp. 325–335, 2002.
- [63] C. M. Milkie and A. N. Perakis, "Statistical methods for planning diesel engine overhauls in the U.S. Coast Guard," *Naval Eng. J.*, vol. 116, no. 2, pp. 31–42, 2004.
- [64] *Rules for Building and Classing Mobile Offshore Drilling Units: Part 4—Machinery and Systems*, Amer. Bureau Shipping, Houston, TX, USA, Jul. 2016.
- [65] *Guide for Dynamic Positioning Systems*, Amer. Bureau Shipping, Houston, TX, USA, Nov. 2013.
- [66] C. Dong, C. Yuan, Z. Liu, and X. Yan, "Marine propulsion system reliability research based on fault tree analysis," *Adv. Shipping Ocean Eng.*, vol. 2, no. 1, pp. 27–33, Mar. 2013.
- [67] R. Cornes and T. R. Stockton, "FMEA as an integral part of vessel design and construction: Producing a fault tolerant DP vessel," in *Proc. Dyn. Positioning Conf.*, Oct. 1998, pp. 1–11.
- [68] R. Menis, A. da Rin, G. Sulligoi, and A. Vicenzutti, "All electric ships dependable design: Implications on project management," in *Proc. AEIT Annu. Conf. Res. Ind., Need More Effective Technol. Transf. (AEIT)*, Trieste, Italy, Sep. 2014, pp. 1–6.
- [69] M. Chiancone, A. da Rin, R. Menis, G. Sulligoi, and A. Vicenzutti, "Dependable oriented design of complex integrated power systems on ships," in *Proc. Int. Conf. Electr. Syst. Aircraft, Railway, Ship Propuls. Road Vehicles (ESARS)*, Aachen, Germany, Mar. 2015, pp. 1–6.
- [70] R. E. Hebner *et al.*, "Technical cross-fertilization between terrestrial microgrids and ship power systems," *J. Modern Power Syst. Clean Energy*, vol. 4, no. 2, pp. 161–179, Apr. 2016.



**Giorgio Sulligoi** (S'02–M'05–SM'15) received the M.S. degree (Hons.) in electrical engineering from the University of Trieste, Trieste, Italy, in 2001, and the Ph.D. degree in electrical engineering from the University of Padua, Padua, Italy, in 2005.

He spent an internship at Fincantieri Electric Systems Office, Trieste, and a semester as a Visiting Scholar at the University College of Cork, Cork, Ireland. In 2005, he joined MAI Control Systems, Milan, Italy, an Italian firm operating in the field of power stations and alternator voltage control systems. He joined the University of Trieste as an Assistant Professor of Electric Power Generation and Control in 2007, tenured since 2010, and has been an Assistant Professor of Shipboard Electrical Power Systems since 2012. He is the Founder and Director of the grid connected & marine Electric Power Generation and Control Laboratory at the Department of Engineering and Architecture, University of Trieste. In 2013, he received the national qualification for the level of Associate Professor in Electrical Energy Engineering. He has authored over 100 scientific papers in the fields of shipboard power systems, all-electric ships, generator modeling, and voltage control.

Dr. Sulligoi is a member of IAS, PELS, and PES, where he serves on different technical and standard committees.



**Andrea Vicenzutti** (S'14) received the M.Sc. degree (Hons.) in electrical engineering from the University of Trieste, Trieste, Italy, in 2012, and the Ph.D. degree in industrial engineering from the University of Padua, Padua, Italy, in 2016.

His activity is carried out at the Electric Power Generation and Control Laboratory, Department of Engineering and Architecture, University of Trieste. His research activity is on marine power systems, in particular on power systems design and systems dependability.

Mr. Vicenzutti is registered with the IAS and PES societies.

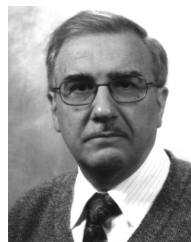

**Roberto Menis** (S'79–M'92) is with the Department of Engineering and Architecture at the University of Trieste, Trieste, Italy, where he is currently an Associate Professor of Electric Drives. His research interests are in the field of electric machines and drives: modeling, identification and control of ac and dc machines, industry and transport applications of the drives, and dependability and functional safety for electrical systems.