

Guide for Obtaining Data from Reaction to Fire Tests

Oct 2018



How to test materials efficiently, what measurements are essential, and expectations for fire modeling.

Co-authors

(sorted alphabetically)

Aitor Barrio (Tecnalia Research & Innovation)
Alexander Pfriem (Eberswalde University for Sustainable Development)
Antonio Galan (Freelance Fire Safety Consultant)
Ayfer Donmez Cavdar (Karadeniz Technical University)
Chiara Bedon (University of Trieste)
Danny Hopkin (Olsson Fire & Risk)
David Barber (Arup)
David Lázaro, Mariano Lázaro, and Daniel Alvear (University of Cantabria)

Edgars Buksans (Forest and Wood Products R&D Institute)
Esko Mikkola (KK-Fireconsult Ltd)
Franz Richter, Izabella Vermesi, and Guillermo Rein (Imperial College)
Johanna Liblik (Tallinn University of Technology)
Kathinka Leikanger Friquin (SINTEF)
Theodor Guggenberger (Rubner Holding)
Tuula Hakkarainen (VTT Technical Research Centre of Finland)
Wojciech Grześkowiak and Bartłomiej Mazela (Poznań University of Life Sciences)

Editors:

Davood Zeinali
Ghent University

Dionysios I. Kolaitis
National Technical University of Athens

Joachim Schmid
ETH Zürich

European Cooperation in Science and Technology



This publication is the result of work carried out within COST Action FP1404 “Fire Safe Use of Bio-Based Building Products”, supported by COST (European Cooperation in Science and Technology). COST is a funding agency for research and innovation networks. The Actions help connect research initiatives across Europe and enable scientists to grow their ideas by sharing them with their peers. This boosts their research career and innovation. More information available at www.cost.eu.



This work may be cited as:

D. Zeinali, D. Koalitis, J. Schmid, Guide for Obtaining Data from Reaction to Fire Tests, ETH Zürich, Switzerland, 2018.

DOI 10.3929/ethz-b-000319575

Version 1 (2018)

Updates and corrections: <http://www.costfp1404.ethz.ch/publications>.

This publication was created in WG1 and can be considered as state of the art-document. The information in the book was carefully selected-by experts from general technical knowledge, standards, most recent research results and building practice. The author(s), the editor(s) and publisher disclaim any liability in connection with the use of this information.

Neither the COST Association nor any person acting on its behalf is responsible for the use of the information contained in this publication. The COST Association is not responsible for the external websites or other references referred to in this publication.

No permission to reproduce or utilise the contents of this publication by any means is necessary, other than in case of images, diagrams or other material from the copyright holders. In such cases, permission of the copyright holder(s) is required.

Table of contents

Preface	1
1. Why test for reaction to fire?	2
2. How to choose the samples?.....	2
2.1. Sample composition.....	2
2.2. Sample size.....	3
2.3. End-use function	3
2.4. Material variations	4
3. How to characterize the sample material?	4
3.1. Sample geometry	5
3.2. Density.....	5
3.3. Thermal inertia.....	6
3.4. Critical heat flux	6
3.5. Surface temperature at ignition.....	6
3.6. Pyrolysis temperature	7
3.7. Thermal conductivity.....	8
3.8. Specific heat capacity.....	8
3.9. Emissivity.....	8
3.10. Moisture content	8
3.11. Heat of combustion.....	9
3.12. Combustion efficiency.....	9
3.13. Heat of gasification versus heat of pyrolysis.....	9
3.14. Heat Release Rate (HRR) and Mass Loss Rate (MLR)	10
3.15. Smoke data.....	10
3.16. Surface properties.....	11
3.17. Char properties	11
3.18. Miscellaneous.....	11
4. Which test to pick?	11
5. How to conduct modified tests for special cases?	13
5.1. Fire scenario	13

5.2.	Orientation of the sample	13
5.3.	Direction of thermal attack	13
5.4.	Number of tests and repeatability	14
5.5.	Specific test considerations.....	14
5.5.1.	Thermogravimetry analysis (TGA)	14
5.5.2.	Differential scanning calorimetry (DSC).....	15
5.5.3.	Cone calorimeter	16
5.5.4.	H-TRIS.....	16
5.5.5.	Pyrolysis Machine	18
5.5.6.	Charring rate chamber	18
5.5.7.	ASTM E69 and Mini Fire Tube (MFT) test methods	18
5.5.8.	Limiting Oxygen Index (LOI)	19
6.	What measurements to make?	20
6.1.	Initial and boundary conditions	20
6.2.	Final conditions	21
6.3.	Visual measurements	21
6.4.	Other important measurements	21
6.5.	Timber considerations.....	22
7.	How to estimate unknown material properties?	23
7.1.	Inverse modeling methodology	23
7.2.	Experiments for inverse modeling	25
7.2.1.	Thermal Analysis	25
7.2.2.	Bench-scale experiments	25
7.3.	Model complexity, certainty and validation	26
7.4.	Optimization methods	27
7.4.1.	Genetic algorithms.....	27
7.4.2.	Shuffled Complex Evolution (SCE).....	27
8.	Concluding remarks	27
	Bibliography	28

Preface

To increase the gain from costly fire experiments and to facilitate engineering calculations of material performance in case of fire, there is an essential need for careful experimental design and proper characterization of material fire properties. In light of this necessity, the ASTM E1591 standard guide [1] provides a compilation of key material fire properties and explains how they may be obtained in consistence with modeling capabilities. Moreover, an engineering guide developed by the Worcester Polytechnic Institute (WPI) [2] provides detailed description of different pyrolysis modeling techniques and makes very useful recommendations on how to arrive at required material properties in accordance with the underlying assumptions in the models.

The present document aims to supplement the aforementioned guides by providing simple guidelines on practical aspects of the experimental procedures and preparations for *reaction to fire* tests in particular, and how to extract useful data from fire tests in general. Essential requirements for quantifying the fire characteristics of materials are identified, including recommendations on how to select and characterize the sample materials, what testing techniques to adopt, and which measurements to opt for. It is noteworthy that in some sections, focus is made on specific materials such as wood or polymers because of their relevance and importance, but generally the provided guidelines apply to other combustible materials as well, unless stated explicitly otherwise.

1. Why test for reaction to fire?

The first step for identifying and quantifying the basic fire properties of construction materials or products is testing their *reaction to fire*. This type of testing helps evaluating the contribution of a product to the early stages of fire development, in terms of ease of ignition, energy release, production of smoke and burning droplets, and flame spread. All these factors in turn determine how appropriate it is to use different materials in new designs, for example in a high-rise building. This is particularly vital for ensuring life safety, e.g. in terms of timely evacuation.

The tests relating to reaction to fire tend to be smaller in scale than *fire resistance* tests, described in EN 13501-2 [3], which is mainly aimed at assessing the capacity of a structure or system to resist the passage of fire from one distinct area to another.

One of the main drivers of reaction to fire testing is compliance with the building regulation requirements, although insurance firms or other relevant authorities may request a better reaction to fire performance to be achieved. Moreover, manufacturers carry out reaction to fire testing in order to design superior products that can compete better on the market.

Assessment and validation of fire modeling codes is another main driver of reaction to fire testing, as being able to make reliable predictions of fire performance through modeling reduces the number of fire tests required to achieve a certain design goal. In this regard, a balanced assessment of the fire modeling codes requires collection of data through extensive measurements via appropriate means and techniques. These testing essentials are summarized in this guide.

2. How to choose the samples?

To the extent possible in a test method, it is essential that the samples reflect the end-use conditions. Correspondingly, several factors need to be considered for preparation of the samples, including:

- Sample composition
- Sample size
- End-use function
- Material variations

These factors are reviewed briefly in the following sections.

2.1. Sample composition

In the case of composite or multilayer materials with substantial non-homogeneous components, separate tests are needed for each component. For instance when determining the gross heat of combustion, a powder sample of approximately 1 gram is required for each layer [4]. In case of more uniform multilayer materials, such as plywood (see Fig. 1), the sample may include all the layers.

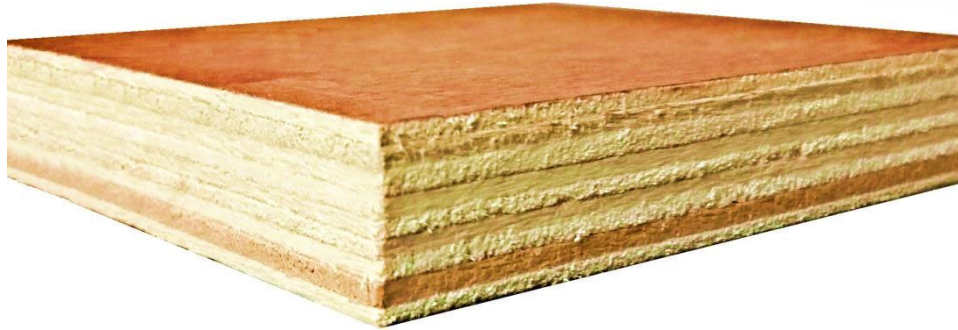

Fig. 1: A plywood sample, as an example of a multilayer material

If the material is to be coated or have varnishing of any kind applied to it upon use, such as regular paint, intumescent paint insulation or any fire retardants, the test sample is best to have the same coating applied to it. This is because the surface properties are very influential on how the material responds to different types of thermal attack (conduction, convection, or radiation).

2.2. Sample size

First and foremost, it is important for the sample to reflect the thickness of the material as in the end-use conditions as closely as possible. This is essential because the thickness defines whether the sample will behave more closely as a thermally thin or a thermally thick material. A thermally thin material is assumed to develop a uniform temperature throughout its bulk, while a thermally thick material is assumed to behave as a semi-infinite solid.

Depending on the type and scale of the desired test, the sample dimensions may be limited or take different forms. In the case of standard testing, the sample size requirements are explained in the related test guide. For instance, when using Thermogravimetry Analysis (TGA) [5, 6], the sample is typically advised to be between 1 and 10 milligrams (see section 5.5.1), so it is most logical for the sample to be in powder form to provide ample surface area. Powder samples, in particular, must always be prepared carefully. If the material is a composite or a multilayer product, the different compositions or layers may have to be considered proportionally or separately (see section 2.1).

2.3. End-use function

It is critical to identify which section of the material needs to be tested based on where the material is used. In other words, it is necessary to consider the function of the material or product as a component in relation to the larger system. For example, the component may be part of:

- Ceiling, floor or wall assembly
- Facade or cladding structure
- Joint systems

Correspondingly, if the material to be tested forms part of a ceiling, floor or wall assembly, the sample should contain a section of the material that is exposed and visible.

In the case of a facade or cladding, external surface flame spread must be considered, and if relevant, cavity fires behind the assembly must also be considered. Moreover, the sample needs to include the entire sandwich assembly, and most preferably be tested from both the surface and the back sides.

With the same logic, if a joint system is to be tested, the outer sections and those parts most vulnerable to failure due to fire must be included in the samples to be tested.

2.4. Material variations

Intrinsically, materials or products to be tested for reaction to fire exhibit variations in their physical and chemical composition and structure, depending on their production conditions, moisture and organic content, etc. Even so, samples taken from a single source tend to show lower levels of such variations. Hence, if repeatability of the fire tests is an issue, it is important that the samples are taken from the same source.

In the case of commercial products, note that normally a certain amount of material is produced as part of a single *batch*, i.e. a fixed material quantity processed simultaneously as part of one operation. Therefore, samples taken from a single batch normally feature less material variation, whereas samples taken from different batches may indicate more variations relative to one another. Hence, if repeatability of the fire tests is a matter of concern, it is important that the samples are taken not only from the same source but also from the same batch. The samples shall also be free of any contaminants, especially in tests with small samples.

With the same logic, in order to analyze the influence of material variations on the results of a fire test, several material sources and batches must be considered, with a few samples from each batch.

In case of fire retardant treated materials, the evenness of treatment distribution should be taken into account as well. For instance, an impregnated wooden panel can have higher concentrations of fire retardant at its edges, thus the edges should be sawn away and samples should be taken from the middle of the panel when possible.

3. How to characterize the sample material?

Little can be learned from a fire experiment if the sample material is not characterized properly. In particular, future analyses may be highly reliant on information such as sample geometry, density of virgin and char, thermal inertia and so on. The following sections provide brief guidelines on how to perform this characterization.

3.1. Sample geometry

The exact dimension and shape of the sample must be characterized, including thickness, width, height, whether the sample is square, round, multilayered, etc.

For better clarity and for future consideration, it is recommended that several pictures are taken from the sample from different view angles.

3.2. Density

Density can be determined by measuring the mass and dividing by the volume of the sample. For volume estimation, the following methods are used conventionally [7]:

- *Method A—Direct Measurement*
 - When the sample is regular in shape with smooth surfaces and right-angle corners, the volume can be determined by linear measurement.
- *Method B—Water Immersion*
 - When the sample is irregular in shape or has rough surfaces, the volume can be determined by measuring the volume (or mass) of the water displaced as the sample is submerged in a container (on a balance).
- *Method C—Flotation Tube*
 - For an elongated sample of uniform cross section, the volume can be determined by measuring the volume of the water displaced as the specimen is submerged in a graduated tube.
- *Method D—Forstner Bit*
 - For elements such as logs from which it would be difficult to saw a flat sample, a fixed volume can be extracted using a Forstner bit.
- *Method E—Increment Core*
 - A technique used for standing trees, but also suitable for logs, poles or other structural elements, which involves extraction of a fixed volume using an increment borer.
- *Method F—Water Immersion for Chips*
 - Specifically for chips of wood or similar materials, involving submerging 300-350 grams of the chips for an hour, draining and centrifuge at 800 to 1200 rpm for 1 to 4 min, after which a water displacement measurement is made using a water container on a balance and a free hanging chip holder.

A more recently used nondestructive method for determining density of irregularly shaped samples is 3D scanning. This can be done using various techniques, such as industrial Computed Tomography (CT) scanning with X-ray [8] or structured-light 3D scanning based on light projection [9].

The temperature dependence of density can be determined using Simultaneous Thermal Analysis (STA) as in [10], with mass changes monitored using thermogravimetric analysis [5] and dimensional changes monitored using Dilatometric Analysis [11].

3.3. Thermal inertia

Thermal inertia is a convenient measure of how fast a material heats up when exposed to heat. In essence, the thermal inertia of a material is the product of its thermal conductivity (k), density (ρ), and specific heat capacity (C_p). Therefore, the thermal inertia can be determined by measuring each of these three parameters separately, or, it can be determined effectively based on a time-to-ignition data analysis.

The procedure for conducting a time-to-ignition data analysis is described in detail in the engineering guide developed by WPI [2]. Most conventionally, the apparatus used for this purpose is a cone calorimeter [12], or a Fire Propagation Apparatus (FPA) [13]. Alternatively, a LIFT apparatus [14] can be used. As part of the analysis, it is required to obtain the critical heat flux for ignition (see section 3.4) and times of ignition under a representative range of incident heat fluxes (typically between 15 to 75 kW/m²).

3.4. Critical heat flux

The lowest heat flux capable of heating the surface of a material to its ignition temperature is known as the critical heat flux. The knowledge of this parameter is essential for engineering calculations and ignition data analysis.

A bracketing technique can be used to determine the critical heat flux. This technique requires conducting multiple ignition experiments at gradually decreasing heat flux levels until no ignition occurs after a reasonably long period (of the order of 30 min [12]). Heat flux decrease level of 5 to 10 kW/m² between each two experiments is recommended initially, while this needs to be refined to 1 to 2 kW/m² when approaching the critical value of heat flux.

3.5. Surface temperature at ignition

The surface temperature at the time of ignition is commonly assumed to be characteristic of the material and is considered vital for engineering calculations [15]. This parameter remains reasonably constant at heat fluxes higher than 25 kW/m², because the sample continues to behave as an inert solid under such heat fluxes up until ignition [2].

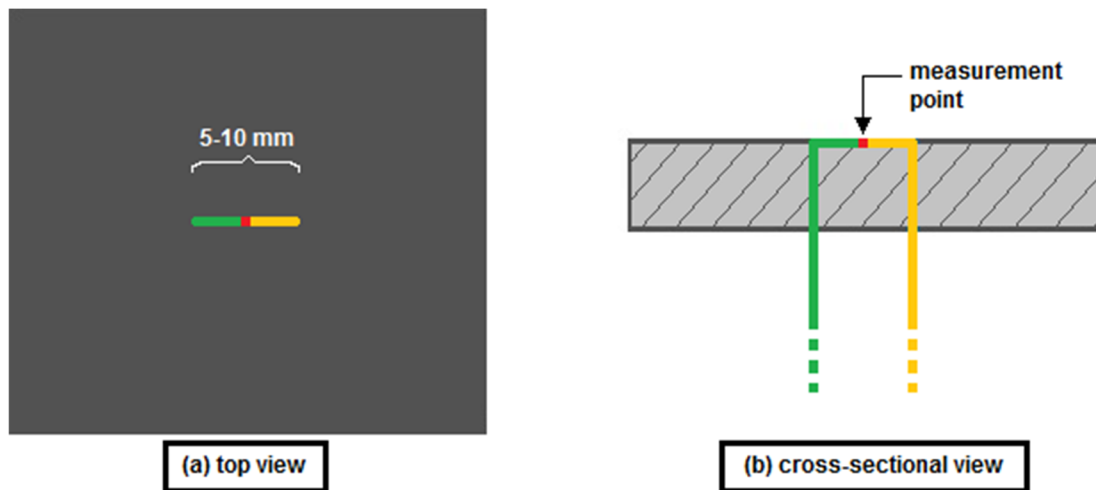

Fig. 2: Surface temperature measurement using a butt-welded thermocouple: the thickness of the thermocouple wires (shown in green and yellow) is recommended to be on the order of 0.25 mm.

The surface temperature at ignition can be obtained directly using a fine thermocouple, recommended to be 0.25 mm thick and butt-welded (commercially available), as shown in Fig. 2. Thicker thermocouples, or those welded with a bead, are not recommended because of their noticeable radiation absorption and response delay.

As an alternative to a direct thermocouple measurement, one can use time-to-ignition data analysis to obtain an estimate of the surface temperature at ignition [2].

3.6. Pyrolysis temperature

Pyrolysis is the simultaneous chemical and physical change of a solid that provides the gaseous fuel feeding the flame burning over a solid fuel [16]. This is considered to happen in a relatively narrow temperature range for most construction materials, with the chemical reactions accelerating as the temperature increases. Taking wood as an example, this increase is especially rapid between 200 and 400°C. This fact has led to the introduction of the concept of a pyrolysis temperature [17], i.e., a set temperature at which pyrolysis is assumed to take place instantaneously. In the case of wood, the pyrolysis temperature is commonly assumed to be about 300 °C.

Assuming a fixed pyrolysis temperature is a simplified modeling approach, implying that pyrolysis is solely governed by heat and mass transfer, while in fact chemistry plays a significant role too [17]. Consequently, state-of-the-art modeling practices tend to consider the underlying chemistry instead, namely in terms of one or several reactions with appropriate kinetic parameters [18].

There are several ways to estimate the pyrolysis temperature, somewhat comparable to kinetic models [19]. This may be achieved using thermogravimetric analysis by employing various heating rate levels,

as in [20]. Alternatively, it may be approximated to be slightly lower than the piloted ignition temperature. In that case, the pyrolysis temperature can be estimated either via direct measurement of surface temperature at ignition, or via inverse modeling (see section 7.1).

3.7. Thermal conductivity

An effective thermal conductivity can be obtained most conveniently based on the transient hot wire approach using a Heat Flow Meter Apparatus according to ISO 8301 [21], or using a Transient Plane Source (TPS) Apparatus [22, 23]. The more time-consuming steady-state approach constitutes using a Guarded Hot Plate Apparatus according to ISO 8302 [24].

Note that effective thermal conductivity is not an intrinsic material property. Rather it is a specimen property that may depend significantly on the sample thickness and testing conditions. Therefore, it is recommended to be determined at conditions applicable to the end use of the material.

3.8. Specific heat capacity

Differential Scanning Calorimetry (DSC) [25, 26] can be used to determine the specific heat capacity over a large temperature range, typically from 20°C to 800°C [27]. The sample is generally recommended to be heated at a constant rate of temperature change of 10°C/min.

3.9. Emissivity

For the normal direction of propagation or incidence to the surface, the emissivity can be determined using spectrometers [28] or other inspection meter techniques [29, 30]. For a total hemispherical emittance, a vacuum emittance test can be used [30, 31].

3.10. Moisture content

The properties of wood and wood-based materials vary significantly based on moisture content. In particular, moisture contents higher than 10% (dry basis) are important to be quantified.

The most standard and accurate method for determining the moisture content is the oven drying method [32]. This requires a forced-convection oven maintained at a temperature of $103 \pm 2^\circ\text{C}$ with venting for evaporated moisture, and a balance to weigh the sample before and after drying. In order to determine the moisture content with a precision of 1%, the balance is recommended to be accurate to a minimum of 0.1% of the nominal oven-dry mass of the specimen [32]. That is to say, a 100 gram sample should be weighed using a balance with a precision of 0.1 gram.

The moisture content is commonly expressed on a dry basis:

$$\text{Moisture content \%} = \frac{m_{\text{initial}} - m_{\text{dried}}}{m_{\text{dried}}} \times 100 \quad (1)$$

where $m_{initial}$ is the initial sample mass and m_{dried} is the dried sample mass (determined when no considerable change is noted in mass readings made every 4 hours). Thus, note that the moisture content expressed on a dry basis can exceed 100%. For other methods of determining moisture content, refer to ISO 13061 [32] or ASTM D4442 [33].

For large specimens, at least one representative sample may be cut for the determination of the moisture content. In case of solid wood, if no sample can be cut, a moisture meter can be used according to EN 13238 [34] or ASTM D7438 [35]. However, note that meter readings are to be corrected for temperature and species, and are considered to be only approximate values.

3.11. Heat of combustion

The energy content of a combustible material can be quantified through its heat of combustion, defined as the heat produced when a unit mass of the material is oxidized.

The total energy content of a material can be determined using an oxygen bomb calorimeter [4], using which a known mass of the material is burned completely in adiabatic condition containing pure oxygen. This is expressed either in terms of the higher heating value or *gross* heat of combustion, or in terms of the lower heating value or *net* heat of combustion. The latter can be obtained by subtracting the latent heat of vaporization of water (2.26 kJ/g) from the gross heat of combustion.

An effective heat of combustion is recommended to be obtained as well. This is in addition to the total heat of combustion explained above, and can be obtained using a cone calorimeter [12], or an FPA [13] in normal atmospheric conditions.

3.12. Combustion efficiency

In real fires, the energy content of the fuel is seldom released completely, because the combustion of fuel vapors is incomplete and any secondary products or residuals are often not given sufficient time or initial energy to oxidize. This is often expressed in terms of the combustion efficiency, i.e., the effective heat of combustion divided by the total heat of combustion (see section 3.11).

3.13. Heat of gasification versus heat of pyrolysis

The heat of gasification of a material is the energy required to heat up its surface such that a unit mass of the material is converted to volatiles. In contrast, the heat of pyrolysis is the energy released or gained after a unit mass of the virgin material undergoes the pyrolysis reaction [36, 37]. In other words, the heat of pyrolysis is equal to the enthalpy difference between the virgin material and the pyrolysis products. If the material vaporizes completely after pyrolysis, the heat of gasification and the heat of pyrolysis are equal, but if there is any leftover char, the two are not equal [38].

The burning rate is often estimated in engineering calculations using the heat of gasification. As proposed by Tewarson and Pion [39], the effective value of heat of gasification is the slope of the best line fitting to a plot of net heat flux exposure against the mass flux of the volatiles. This method has been discussed in [2] along with useful examples.

The heat of pyrolysis is used in contemporary fire models such as FDS [40] and FireFOAM [41], capable of computing the development of pyrolysis within a solid material at elevated temperatures. The heat of pyrolysis can be determined using DSC [25], or using Differential Thermal Analysis (DTA) with TGA [5], by comparing the heating of a small sample against a reference material. Alternatively, inverse modeling can be used to arrive at the heat of pyrolysis based on experimentally obtained data of temperature and mass loss [42] (see section 7.1).

3.14. Heat Release Rate (HRR) and Mass Loss Rate (MLR)

Arguably the most important parameter defining the effects of a fire is the Heat Release Rate (HRR) [43]. This is the rate of energy release, i.e., the mass loss rate multiplied by the effective heat of combustion of the material. Thus, the heat release rate is not a material property, as it depends on the fire environment and the combustion efficiency of fuel volatiles, among other parameters.

For the purpose of determining the HRR for small material specimens, the cone calorimeter [12] or the FPA [13] may be used. In such cases, it is recommended that the mass loss is monitored using a scale with an accuracy of ± 0.1 g or better. Subsequently, the mass loss or burning rate is recommended to be calculated using differentiation schemes using five points or higher [12]. For larger specimens, the furniture calorimeter [44] can be used, with sample weighing accuracy of at least ± 150 g.

The oxygen depletion method [45] may be used to calculate the HRR, assuming that bio-based materials produce a nearly constant amount of energy, E_{O_2} , per unit mass of oxygen consumed for complete consumption. E_{O_2} is considered to be approximately 13.1 MJ/kg. However, the use of this general value for E_{O_2} results in an expected error band of $\pm 5\%$. If the material is homogeneous and exhibits only a single dominant pyrolysis mechanism, this uncertainty can be reduced by determining E_{O_2} using the total heat of combustion (section 3.11) and the stoichiometric oxygen/fuel mass ratio of the material from ultimate elemental analysis [46].

3.15. Smoke data

Smoke density and toxicity are highly important in evacuation problems. This is also a matter of interest for evacuation modeling, e.g. using CFD software. The smoke density evaluation technique described in ISO 5659 [47] can be used for measuring a wide range of toxic species, based on Fourier Transform Infrared (FTIR) spectroscopy [48].

3.16. Surface properties

Roughness, fissures, color, resin, knots and other properties of all sides and surfaces of the sample material must be characterized, because these define how the material heats up when exposed to different modes of thermal attack. Accordingly, it is important to take ample pictures of the sample.

3.17. Char properties

The fire behavior of a bio-based material depends significantly on its char properties. Thus, it is important to characterize the residual char, just as the virgin material, to determine its density, total heat of combustion, thermal conductivity, specific heat capacity, and emissivity.

3.18. Miscellaneous

If the material has been treated with a fire retardant, it is vital to note the used retardant quantity and processing type (physical or chemical). This helps understanding what pyrolysis mechanisms and gaseous products can be expected upon thermal degradation of the material.

The temperature dependence of some material properties such as emissivity and thermal conductivity is possible to be monitored experimentally and to be included in engineering calculations. Hence, where possible, it is highly recommended that the material properties are measured at representative elevated temperatures.

It is also important to note the source ingredients of the sample. For example, engineered wood manufacturers tend to use certain specific wood species to manufacture their panels. Accordingly, characterizing the type of wood species used and the quantity of resin or other additives applied, can provide a rough estimate of the thermal properties of the panels (e.g. for thermal conductivity determination).

4. Which test to pick?

The characterization of material properties is possible with standard small-scale tests such as TGA [5], DSC [25], cone calorimetry [12] and other similar tests presented in section 3, allowing to obtain the basic parameters required for engineering calculations and numerical models in particular.

After characterization of the material properties, medium- or large-scale tests are needed for understanding the behavior of the material in a more practical scale, allowing to capture effects such as flame spread, melting, etc. This phase of testing also allows to validate numerical models which make predictions based on basic material properties discussed in section 3. The main standard reaction to fire tests available for these evaluations are described in Table 1.

Table 1. Main standard reaction to fire tests for evaluation of fire properties in medium or large scale

Test method	Description and objectives
Lateral flame spread test <ul style="list-style-type: none"> • ISO 5658-2 [49] • Medium scale (15 x 80 cm² samples) 	A long sample is fixed on a substrate wall with its longer dimension oriented horizontally and is exposed to a gas-fired radiant panel fixed with an angle of 15° with respect to the sample, while a non-impinging pilot flame at the hot end of the sample serves as the ignition source. Visual observation is made of horizontal flame spread rate, and critical heat flux can be calculated based on the extent of horizontal flame spread.
Vertical flame spread test <ul style="list-style-type: none"> • ISO 5658-4 [50] • Medium scale 	A vertical sample is exposed to a radiant panel, fixed with an angle of 30° near the bottom of the sample, and a pilot flame serves as the ignition source at the bottom. Vertical flame spread rate is monitored.
Single burning item test <ul style="list-style-type: none"> • EN 13823 [51] • Medium scale (150 x 100 cm² and 150 x 50 cm² samples) 	A long and a short panel are mounted perpendicular to each other to create a corner, and a propane gas burner located near the corner serves as the ignition source. The total HRR (kW) and smoke production rate (m ² /s) are monitored, while visual observation is made of flame spread and burning of any falling droplets or particles.
External fire exposure to roofs <ul style="list-style-type: none"> • CEN/TS 1187 [52] • Medium scale (100 x 40 cm² samples) 	The material, in combination with its substrate, is mounted as a sloping roof and exposed to different air velocities and supplementary radiant heat, while a wood crib on the roof serves as the ignition source. Visual observation is made of flame spread along the roof, and recording is made of the specimen ignition time, as well as the time at which the flames die out. The ability to withstand flame spread is evaluated in terms of the length of damaged material in both the roof covering and the substrate.
Radiant panel test for floorings <ul style="list-style-type: none"> • ISO 9239-1 [53] • Medium scale (105 x 23 cm² samples) 	The material is fixed as a horizontal floor and exposed to a defined heat flux under a gas-fired radiant panel which is inclined at 30°, with a pilot flame serving as the ignition source at the hotter end of the specimen. Visual observation is made of flame spread along the length of the material, and the propagation rate of the flame front is recorded.
Room corner test <ul style="list-style-type: none"> • ISO 9705-1 [54] • Large scale (360 x 240 cm² and 240 x 240 cm² samples) 	A surface product is mounted on the inside of a room with a single doorway, covering the ceiling and all the walls except for the doorway wall, and a propane gas burner located in one corner serves as the ignition source. The total HRR (kW) and smoke production rate (m ² /s) are monitored, while visual observation is made of flashover, flame spread along the walls and ceiling, as well as burning of any falling droplets or particles. Toxic gases can also be monitored using FTIR [48].

5. How to conduct modified tests for special cases?

If the experiments to be conducted do not fall within the framework of a standardized test, the study objectives must be defined clearly and be considered in the design of the tests. Accordingly, several main factors are recommended to be taken into account which are discussed in the next subsections.

5.1. Fire scenario

It is vital to identify the main modes of thermal attack in every particular problem at hand. For instance, the case of a wall material placed in a vacuum or near-vacuum environment requires evaluation of *radiation* heat transfer. In this particular fire scenario, convection or conduction are not very relevant modes of heat transfer to the material.

It is likewise essential to identify relevant patterns of heat flux exposure to be considered. For instance, some fire retardants or intumescent paints perform best under short periods of high heat fluxes but exhibit poor performance under long periods of lower heat fluxes (similar to early stages of fire development). Thus, it is vital to investigate and characterize material response to both high and low levels of heat flux magnitude and exposure times, representing various fire scenarios possible. Similarly, both constant and varying heat flux scenarios are recommended to be considered.

Any special aspect of the case under study, such as air gaps, cavities, grid structures, flammable substrates, vicinity to liquid fuels, and so on, need to be considered as well in the medium- to large-scale fire scenarios to be tested.

5.2. Orientation of the sample

The orientation of material in its end-use condition is one of the most important factors defining how the sample should be tested. For example, if the material in its final application is part of a facade, tests must be performed with a vertically oriented sample to evaluate the material propensity for upward flame spread. In such cases, the effects from the scale of the set-up need to be studied too.

5.3. Direction of thermal attack

It is recommended to consider cases where the material is exposed from sides or edges, if applicable in the end-use conditions. In other cases, it is advisable to fix and wrap the sides using aluminum foil and to use supporting insulation to prevent unquantified heat sinks.

Some materials possess different front and back properties, such that different ignition times or fire classifications are achieved if the sample is tested with front or back exposed. This is particularly the case if the material is anisotropic in nature. In such cases, it is important to take the final use of the material into account and make design considerations preferably based on the results of both tests with front and back exposed.

5.4. Number of tests and repeatability

The total number of tests depends on the following main factors:

- *Range of thermal attack*
 - A representative set of heat fluxes and modes of thermal attack needs to be considered. For instance, for ignition data analysis with a cone calorimeter [12], heat flux increments of 5 to 10 kW/m² are recommended between 15 and 75 kW/m², while this needs to be refined to 1 to 2 kW/m² when approaching the critical value of heat flux.
- *Repeatability of findings*
 - It is best to repeat important tests for several times to confirm findings. For instance, FPA tests [13] are best to be performed for 3 times at any given heat flux exposure, and average values are advised to be considered.
- *Uncertainty and statistical analysis*
 - Just as tests are performed to confirm repeatability, it is also important to establish a range of certainty for the outputs by having a reasonable population of samples and tests. As part of a statistical analysis, a 95% confidence level can be considered to establish certainty, assuming either a t-distribution (when the number of tests is small) or a normal distribution (when the number of tests is large).
- *Initial and boundary conditions*
 - To reduce the number of tests required for repeatability studies, such that tests yield reliable data and are reproducible by other researchers, it is important to fix the initial and boundary conditions of the tests and quantify them as much as possible. For instance, the samples must be conditioned before every experiment. Likewise, it is important to quantify heat losses from the back or sides of the samples via temperature measurements. For CFD validation, measurements of boundary conditions in the gas phase are important, such as air flow or velocity, gas temperatures, etc.

5.5. Specific test considerations

5.5.1. Thermogravimetry analysis (TGA)

When conducting TGA tests, the following main items are recommended to be considered carefully:

- *Sample mass*
 - TGA relies on the assumption that the sample mass is small enough to have a uniform temperature evolution upon heating. In other words, thermal inertia

should not affect the decomposition of the sample. Therefore, the sample mass is recommended to be between 1 and 10 mg. Small masses are needed at high heating rates (e.g. 2 mg at 10°C/min), while larger masses are needed at lower heating rates (e.g. 10 mg at 2°C/min) [55].

- *Rate of temperature change*
 - The heating rate can affect the type of decomposition reactions happening [56]. Typically, the temperature is increased at a fixed rate, between 1 and 60 °C/min, to a predefined maximum temperature (1000°C or higher).
- *Gas flow over the sample*
 - For most analyses, the gas flow rate should range between 10 to 100 mL/min, but higher flow rates may be used for high heating rates.
- *Degradation mechanisms*
 - A single mass loss step may not always correspond to a single-step degradation mechanism [55]. In order to identify any overlapping degradation steps, tests at different heating rates must be conducted.

5.5.2. Differential scanning calorimetry (DSC)

The following main items are recommended to be considered carefully for DSC tests:

- *Sample mass*
 - Much like TGA samples, DSC samples are required to be small (see section 5.5.1). As a rule of thumb, the sample mass times heating rate should not exceed 100 mg °C/min [55]. For kinetic studies, sample masses as small as 1 mg can be sufficient. If the mass loss is very small, i.e. less than three times the standard deviation of the noise in a blank signal (in a test with an empty pan), the sample mass should be increased to at least 10 times larger than the aforementioned standard deviation in order to allow for reliable measurements. Furthermore, note must be taken that at high heating rates, the heat flow increases proportionally to the heating rate. As a result, it is required to choose an appropriate sample mass by analyzing a series of tests with decreasing sample masses [55].
- *Heating rate*
 - For materials which could melt, the reaction kinetic parameters applicable for the liquid state may be different than those applicable for the solid state. In such cases, two different sets of kinetic parameters may be determined, namely, one for the solid state based on experiments below the melting temperature with very slow heating rates, and another for the liquid state based on tests above the melting temperature with regular heating rates.

5.5.3. Cone calorimeter

In addition to the general requirements of ISO 5660 [12], especially for the purpose of studying the charring of timber [57-59], the following recommendations could be taken into account:

- Irradiance levels within the range of 50 – 75 kW/m², with an incident heat flux level of 50 kW/m² during the first 20 minutes and any heat flux rising done afterwards, yields results comparable to furnace test results during the first 30 minutes [60, 61].
- Temperatures can be recorded using thermocouples to detect the start time of charring and to determine in-depth temperatures throughout the test. Thermocouples should be inserted horizontally to follow the isotherms, and be fixed at points along the center line of the specimen. The charring rate can then be determined by examining the residual cross-section.
- A better agreement with the temperature measurements recorded in furnace tests could be achieved if the specimen is fixed at a height closer to the cone heater. Similarly, higher irradiance levels match more closely with the fire exposure in fire resistance tests [62].
- Despite the stated limitation of 0.05 m for the sample thickness in ISO 5660 [12], studies show that it is feasible to use a cone heater to investigate the performance of materials with a thickness of more than 0.05 m [57, 61].

Several limitations should be considered:

- The small size of the specimen in cone calorimeter tests limits the examination of the material's physical and mechanical behavior, especially if the results are to be used for larger scale predictions. In particular, it is not possible to directly determine the fall-off time of protection material or self-extinction phenomenon [63].
- The performance of a sample in the cone calorimeter depends on the test procedure and set-up, including the ignition source, ventilation, irradiance level, temperature, and the geometry of the specimen [64]. All aspects need to be considered when drawing conclusions. For instance, in case of timber, the insertion of thermocouples, variability of timber sample density and the orientation of its wood fibers may influence the test results considerably.
- The small-scale tests cannot be a replacement for larger scale tests such as furnace or facade tests, however a reasonable prediction is possible. For that purpose, it is important to consider the differences between furnace and cone tests in terms of heat transfer and boundary conditions, such that the cone test data is used appropriately.

5.5.4. H-TRIS

The Heat-Transfer Rate Inducing System (H-TRIS) [65] (shown in Fig. 3) is a novel medium-scale apparatus developed as part of a collaboration between the University of Edinburgh and the University of Queensland. This apparatus can control the time-history of radiant heat flux received at the surface

of a sample in a highly repeatable way and at a cost lower than available with traditional furnace test methods.

Not only can H-TRIS be used for controlling the time-history of incident radiant heat flux (e.g. constant, varying linearly, etc.), but also it can be used for controlling the time-history of temperature distributions within the tested sample as desired. This enables simulation of thermal boundary conditions, such as those observed during a standard furnace test or those calculated using a fire model (e.g. zone or computational fluid dynamics models).

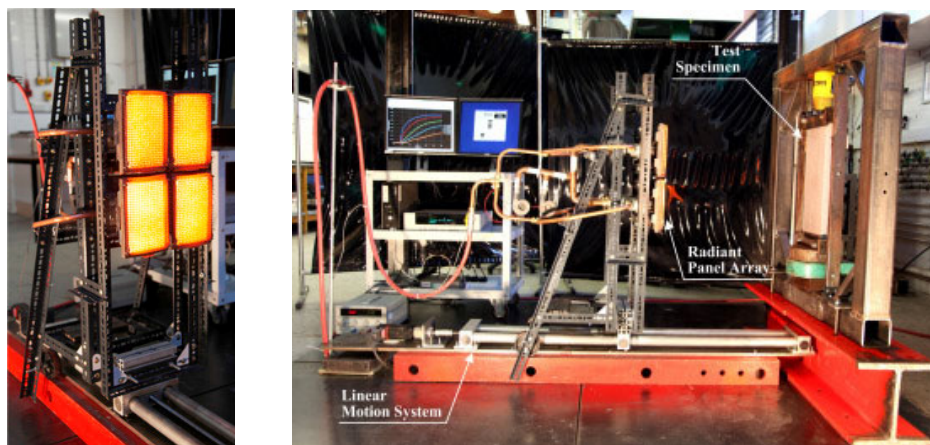

Fig. 3: The H-TRIS apparatus [65].

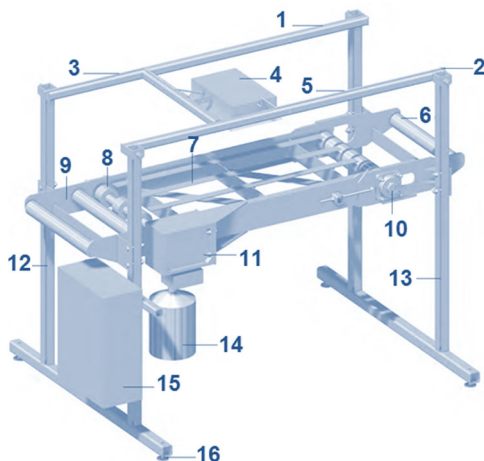

Fig. 4: Pyrolysis machine: (1) Energy source carrier, (2) Propane connection, (3) CO₂ line, (4) Gas burner, (5) Propane gas line, (6) Pick-up reel, (7) Slide rails, (8) Drive gear, (9) Conveyor belt frame, (10) Conveyor belt tensioner, (11) Drive gear, (12) Nitrogen connection, (13) Base frame, (14) Motor, (15) Control cabinet, (16) Rotary feet.

5.5.5. Pyrolysis Machine

The pyrolysis machine [66] (Fig. 4), developed and built by Eberswalde University for Sustainable Development, is a novel apparatus capable of producing targeted pyrolysis layers on wood surfaces in a continuous process, partially automated and using different radiation sources. By varying the process parameters on the machine (inert gas atmosphere, feed rate and treatment temperature), pyrolysis layers with variable layer thicknesses and material properties can be reproducibly produced on different deciduous and softwoods as well as on wood-based panels. In addition, the pyrolyzed test specimens could be studied in terms of mechanical properties and the related hygric behavior.

5.5.6. Charring rate chamber

In the case of materials in the form of panels, a pre-heated charring chamber [67] can be used to determine the charring rate with a radiant heat source of 2.4 kW power, diameter of 0.17 m. This apparatus also allows determining the ignition temperature and weight loss of wood and wood-based materials with partially limited air access. The tests can be conducted with panels in different distances from the heater (from 0.05 to 0.25 m) and thermocouples can be used to monitor the temperature of the sample. After the test, the charring layer can be collected from the central part of the sample to estimate the char depth and the speed of charring (mm/min). Correlation with furnace tests (standard and natural fire curves) needs to be investigated.

5.5.7. ASTM E69 and Mini Fire Tube (MFT) test methods

The ASTM E69 test method [68] (Fig. 5) is widely used for evaluating the effectiveness of fire retardant treatment on the general combustible properties of wood and wood-based materials. This test method is used to provide a relative measurement of flammability based on percentage of sample mass loss, O₂, CO and NO gas outputs, during a controlled fire exposure. In addition, other possible data include rate of weight loss, time of flaming and after-glowing, increase in temperature, and maximum vertical flame progress. The fire source is a gas burner with an outlet diameter of 9.5 mm and a flame height of 0.25 ± 0.05 m. The sample dimensions are 0.01 x 0.02 x 1 m, exposed to the flame for a period of 4 min. The test scale is not large enough to evaluate the suitability of a given treated product for building construction, but it is a suitable method to use for purposes of development or as a quality-control test during manufacture.

The Mini Fire Tube (MFT) test method [69] (Fig. 5) is an adopted and modified ASTM E69 method, with sample dimensions of 0.01 x 0.05 x 0.10 m and a flame exposure period of 3 min. In this test, the effectiveness of fire retardant treatment is evaluated based on the following formula:

$$W = 10 \times (1 - E/A) \quad (2)$$

where W is the effectiveness of fire retardant treatment, E is the final weight loss after burning of the treated wood sample (in %), and A is the final weight loss after burning of the source wood sample

without treatment (in %). The fire retardant treatment is considered effective when $W \geq 7.5$ and the sample must extinguish after 1 minute from the moment the fire source is taken away.

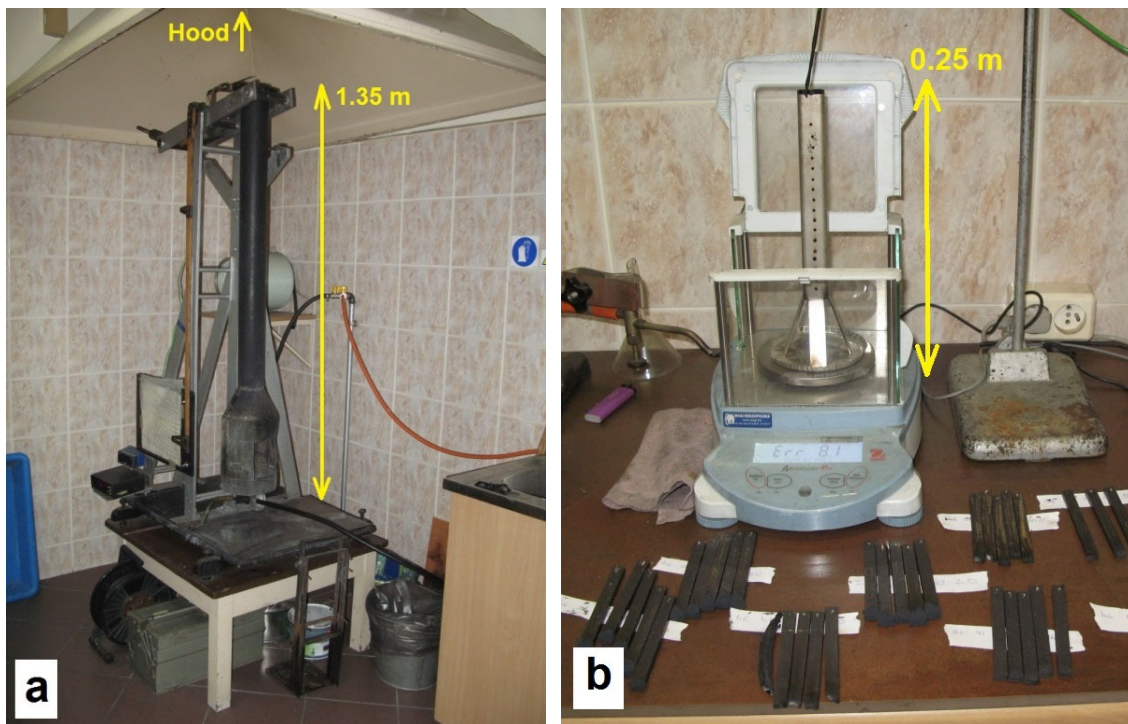

Fig. 5: Apparatuses of test methods of (a) ASTM E69 [68] and (b) MFT [69].

5.5.8. Limiting Oxygen Index (LOI)

The test method of Limiting Oxygen Index (LOI) [70] primarily was developed for plastics, but it has been used to determine reaction to fire performance of wood and wood products as well, because determining the oxygen index in this test requires a relatively small sample and yields a single numerical value compared to other methods [71, 72]. This was also confirmed by White [73] that the test results are a suitable indicator of the relative flammability of wood and wood products, and defined a related flame spread index, *FSI*, as follows [73]:

$$FSI = -9.055 + 2687/LOI \quad (3)$$

This test can be supplemented with TGA [5] and ASTM E69 [68] tests for more in-depth analysis [74, 75]. As shown in Fig. 6, the samples are oriented vertically on a sample holder in a glass chamber with adjusted gas flow (oxygen and nitrogen mixture), based on the requirements of ISO 4589 [70] or ASTM D-2863 [76]. Each sample is ignited with a flame and is left to burn downward. Subsequently, minimum oxygen concentrations which would support combustion are recorded as LOI in percentage.

Accordingly, a reaction to fire classification can be assigned to the material (see Table 2), although correlation with European test methods and classifications needs to be investigated.

Table 2. Reaction to fire classification based on LOI [70]

LOI %	Classification of Fire
≤ 23	Combustible or Flammable Material
24–28	Limited Fire Retarded or Fire Resistant Material
29–35	Fire Retarded or Fire Resistant Material

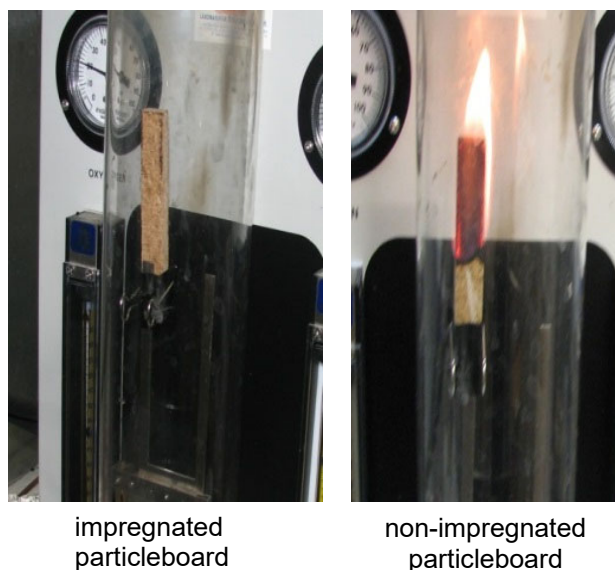

Fig. 6: LOI testing of particleboard with and without fire retardant impregnation treatment [77].

6. What measurements to make?

As fire tests are often costly and time-consuming to perform, it is recommended to make comprehensive measurements during every test. The following sections discuss the essential measurements.

6.1. Initial and boundary conditions

For the possibility of future engineering calculations and modeling, it is vital to make measurements of initial and boundary conditions during the test. Most essential measurements include:

- Ambient temperature, relative humidity and atmospheric pressure
- Time history of heat fluxes on the surface of the sample

- Temperatures within and around the boundaries of the sample
- Flow conditions (temperature, flowrate, velocity, etc.) of incoming air and combustion gases
- Initial mass, geometry, temperature, and composition of the sample

6.2. Final conditions

It is often overlooked that final conditions provide very valuable insights about the fire properties of the tested material. It is particularly important to note the final mass, volume, temperature, and composition of the residual sample. Furthermore, any leftover char can be tested for its total energy content (section 3.11) so that a more accurate prediction of HRR can be made for the raw material.

6.3. Visual measurements

Pictures of the sample, set-up and equipment, should be taken both before and after the experiment from various angles. This is very helpful for future analysis and presentation of the test results.

It is also essential to film the entire fire test, using a camera with high resolution and number of frames per second, fixed properly on a tripod or a similar structure. This helps analyze the different parts of the test, e.g. for ignition times, flame spread, and so on.

6.4. Other important measurements

Considering the limitations and scale of the specific apparatus at hand, the following measurements are advisable:

- *Changes in the mass of the sample*
 - It can be used to estimate the HRR based on the heat of combustion.
- *Charring evolution through depth*
 - This helps determine the mechanical strength of load-bearing structural elements, and can be used to calculate mass loss and HRR.
- *Time to flashover*
 - It is important for compartment fire scenarios.
- *Delamination times and patterns*
 - When exposed to fire, some materials tend to delaminate [78]. This involves mechanisms which play a significant role in material flammability and structural integrity [79]. For instance, self-extinction of cross-laminated timber in a compartment fire could relate to its initial delamination [63].

- *Oxygen calorimetry*
 - This allows determination of the HRR.
- *Velocity of gases*
 - Flowrate calculations can be made based on gas velocities, and comparisons can be made with CFD modeling results to assess simulation quality.
- *Gas temperatures*
 - Temperatures in the smoke layer, or near important boundaries are useful.
- *Pyrolysis and flame spread (front, height and length)*
 - This is an indication of material flammability that is important for prediction of fire development both inside a compartment (on the walls, furniture, etc.) and outside it (on the facade).
- *Surface and in-depth temperatures*
 - This can be used for tracking of charring, ignition data analysis, and for fire model evaluations.
- *Heat flux distributions*
 - This constitutes an important boundary condition for engineering calculations and assessment of modeling capability.
- *Production of soot and composition of smoke*
 - Monitoring and predicting the toxicity level of smoke layer is essential for assessment of time available for safe evacuations.
- *Phase change behavior*
 - Melting or other material behaviors that significantly affect fire spread need to be assessed and characterized to be able to make adequate engineering predictions [80].

6.5. Timber considerations

Timber products (such as cross laminated timber and laminated veneer lumber) to be used as exposed construction material for high-rise buildings has recently been a great area of interest with challenges of its own. In this regard, the following characteristics are important to be quantified:

- *Char fall-off*
 - Char fall-off is known to be linked with adhesive type. A temperature criterion of 200°C has been regularly used [31, 81], but more data is required to understand adhesive failure and the conditions required for char fall-off, for both horizontal and vertical walls, to develop reliable correlations and

quantify its impact on compartment fires. The most conclusive testing of char fall-off has been the medium-scale furnace testing by ETH [11], showing the impact of adhesive types with char fall-off using an ISO 834 standard fire [62].

- *Debonding resistance of adhesives*
 - With the impact of char fall-off becoming more relevant to compartment fires, there have been efforts to change the CLT manufacturing standards to require use of adhesives that do not allow char fall-off when panels are exposed to fire. Therefore, there is a need for quantification of the reaction to fire of CLT adhesives in terms of their debonding behavior, preferably through a repeatable small-scale test which could be standardized.
- *Scaling effects*
 - A conclusive link is needed between small-scale and large-scale testing (e.g. cone calorimeter versus furnace testing), such that important findings such as conditions for char fall-off are repeatable and predictable (see [82, 83]).
- *Charring rate variance with heat flux*
 - Researchers have been working in this area for decades [84-88], developing correlations of how char rates will vary with applied external heat flux, but there is a need for a uniformly adopted correlation.
- *HRR versus location and area of exposed timber*
 - The fire growth in compartment fire tests depends on the location and amount of fuel available, which needs to be quantified carefully.
- *Fire protection materials*
 - Quantified data is needed on the effects of non-combustible coverings.

7. How to estimate unknown material properties?

Most of the material properties may be determined through direct or indirect measurements (see section 3), but this may not be possible for all the properties, thus some unknown parameters need to be estimated. This is particularly needed for some engineering calculations and fire modeling evaluations.

7.1. Inverse modeling methodology

With sufficient experimental data, unknown material properties can be estimated based on inverse modeling using a fire model, with the objective to obtain an optimized set of input parameters yielding model results that closely fit experimental data (mass loss, temperatures, and so on).

Figure 7 shows a schematic view of the conventional methodology that is used for estimation of parameters based on experiments. Firstly, one should carry out tests to collect data. The main experimental methods recommendable for this purpose are described in the next section. After the initial experiments, a computational model is selected and then maximum and minimum ranges must be identified and fixed for the input parameters to be estimated. Next, a simulation is performed using a set of input parameters with values in the fixed range, and the error of simulation is determined by comparing against the experimental results. As long as the error is larger than the expected error, the values of the input parameters are modified by an optimization method (section 7.2). Thus, this process will be repeated until an optimal set of parameters is obtained which meets the expected error margin desired. Different experimental methods and conditions may yield different optimization results nevertheless.

Note that material properties estimated based on inverse modeling are in fact “model-effective parameters” [89], meaning that they are likely model dependent. Hence, modelers should note the techniques and model assumptions used for certain estimated parameter values, especially if they are to be used in a different modeling software. For more information on this topic, the reader is referred to [89].

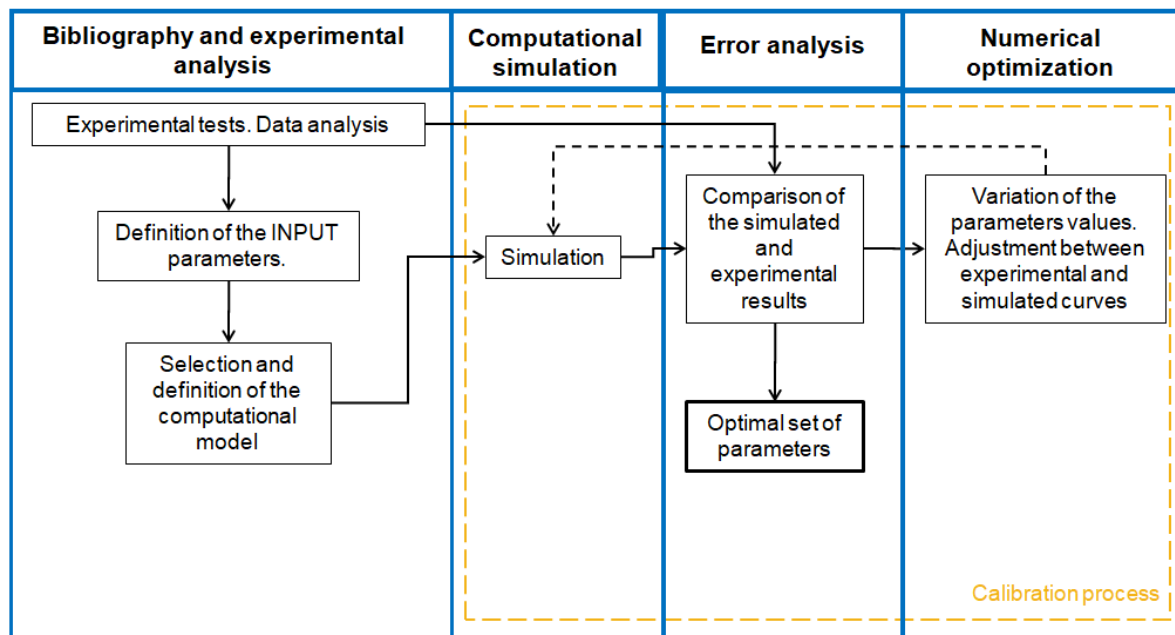

Fig. 7: Schematic of methodology for estimation of parameters based on experiments

7.2. Experiments for inverse modeling

One of the important decisions before estimation of parameters is to select a suitable experiment, i.e., where to apply the methodology described in the previous section (Fig. 7). Each test may provide different features, so this selection should be considered carefully.

The literature features numerous fire experiments that are similar in nature but not suitable for engineering calculations or modeling, as they often lack characteristic data such as temperature or mass loss rate histories, i.e. the two most common quantities to validate models [90]. In this regard, it must be noted that new measurements should always be guided by the need for models [91], and all experiments should be reported with uncertainties and repeats [92].

7.2.1. Thermal Analysis

Thermal analysis is a branch of materials science where the properties of materials are studied as they change with temperature, performed via several methods which are distinguished from one another by the property measured. Regarding estimation of unknown material fire properties, the most commonly used equipment may be TGA [5] and DSC [25]. Note that the samples in these tests are in the order of milligrams.

The results of TGA tests can be used to estimate the kinetic parameters (activation energy, pre-exponential factor and reaction order) by applying different methodologies like Ozawa [93], Vyazovkin [94, 95], and Kissinger [96]. TGA and DSC analyses can also be performed simultaneously by the STA equipment [10]. The design of each STA test should take into account the different boundary conditions that are desired. STA allows to perform tests with different heating rates, oxygen concentrations, sample holders (with or without pans), and mass of samples or gas flows. The influence of these boundary conditions on the thermal decomposition of several polymers are analyzed in [10] and [97].

7.2.2. Bench-scale experiments

For the estimation of unknown material properties, performing bench-scale tests is common in fire science. Commonly used equipment are FPA [13] and cone calorimeter [12].

In both FPA and cone calorimeter, the specimens can be tested in a horizontal (face-up) orientation or, for material which do not melt, in a vertical orientation. An irradiance of 0 to over 100 kW/m² can be imposed, although it can be argued that boundary conditions might be different at very high heat fluxes due to heating up of the testing environment and atmosphere, thus it is more common to test at heat fluxes lower than 75 kW/m², especially in the case of cone calorimeter where the expansion of the heating element can become irreversible after vigorous testing cycles. The HRR is determined by measuring the flow of combustion product gases and performing oxygen depletion analysis [12], while the mass loss is recorded simultaneously using a load cell.

There are several differences in the set-up of FPA and cone calorimeter that could lead to observing a different fire behavior for the same material, as discussed in [98]. Cone calorimeter has an electrical cone heater, while the FPA uses halogen radiant heaters and surrounds the test sample in a quartz tube so that the atmosphere around the sample can be varied. Moreover, the sample holder is square (stainless steel) for the cone calorimeter, whereas it is square or circular (aluminum) for the FPA. Additionally, the pilot used for ignition in the case of cone calorimeter is a spark, while for the FPA, that is an air/ethylene flame. Furthermore, the heating source position is directly above the sample for the cone calorimeter, while for the FPA it is on the side. Regarding the ventilation conditions during the experiments, the main difference can be linked to the presence of air supply under the sample in the case of FPA (200 liter/min recommended in the standard).

7.3. Model complexity, certainty and validation

For the results to be reliable, it is important to incorporate the appropriate level of model complexity. A good rule of thumb [89, 90]: model initially with the simplest approach, and apply extra complexity only when results differ from experimental benchmarks significantly. Therefore, the complexity of the model should directly be related to the experiments [90, 92, 99-101]. In other words, a more sophisticated model is justifiable only in presence of an increased number of experimental measurements. The problems of adding complexity through inverse modeling are explained in [101], and a well-defined methodology for model development has been recently proposed in [102].

Computer fire models such as Fire Dynamics Simulator (FDS) [40, 103] and FireFOAM [41] incorporate complex kinetic models for computation of material behavior at elevated temperatures by considering representative reactions that take place upon thermal degradation of the material. The uncertainty presented by these kinetic models has to be taken into account during inverse modeling, e.g. via sensitivity analysis of the results [104]. In addition to the model uncertainties, there are several other factors that have a quantifiable influence on the inverse modeling results, such as the heating rate or the number of data points considered in the tests [105].

After model-effective material properties have been estimated through inverse modeling, a validation against a test with a different scale or with a different fire scenario should be performed [106, 107]. This extra validation evaluates the extrapolation capability of the optimal set of parameters obtained with the methodology. If the predictions are made before the conduction of the experiments, the practice is known as a priori [108], which is the more compelling validation approach. If the predictions are made after the conduction of the experiments, the practice is known as a posteriori [92], which is acceptable as validation only if the experiments have not been included in the model development process [99]. That is to say, prediction of results of experiments already used in the model development is not considered to be a proper validation.

7.4. Optimization methods

7.4.1. Genetic algorithms

This optimization method has been widely used in the fire community to estimate input parameters for fire modeling based on cone calorimeter test results [109, 110], TGA test results [111, 112] or TGA and DSC test results [113, 114]. The genetic algorithm (GA) methodology solves both constrained and unconstrained optimization problems based on a natural selection process that mimics biological evolution.

7.4.2. Shuffled Complex Evolution (SCE)

The method of Shuffled Complex Evolution (SCE) has also been used widely in the fire community to estimate unknown modeling parameters, e.g. using STA test results [115], TGA [116] or FPA results [117] [33-34]. This method is based on a synthesis of four concepts that have proved successful for global optimization: competitive evolution; clustering; combination of probabilistic and deterministic approaches; and systematic evolution of a complex of points spanning the space in the direction of global improvement.

8. Concluding remarks

A broad range of *reaction to fire* testing methodologies has been developed worldwide, aiming to investigate the underlying physical and chemical phenomena that characterize the fire behavior of construction materials. Reaction to fire tests provide a means to quantify the potential contribution of the investigated material to fire initiation and fire spreading. The obtained test results are commonly used either for material classification purposes, in the context of demonstrating compliance with relevant national regulations, or to determine certain important physical properties. The latter properties are necessary for the successful development and application of fire simulation models. Depending on the desired measurements, reaction to fire tests may employ a wide range of scales (e.g. sample sizes varying from a few mg to entire walls), temperatures (ambient to over 1000°C), heat fluxes, heating rates, etc. As a result, special attention should be paid to the choice of equipment to be used, because each device has specific features and requirements that need to be addressed. In this context, the present work provides a set of guidelines, aiming to assist researchers in answering a series of important questions related to reaction to fire testing, such as “how to choose and characterize the sample” or “which reaction to fire test to select” and “what measurements to make”. In this regard, it is noteworthy that the presented guidelines correspond to the *current* state of the art in the open literature, thus certain pieces of information and guidance may have to be updated in the future to match with the findings of prospective research efforts.

Bibliography

- [1] ASTM E1591-13, "Standard Guide for Obtaining Data for Fire Growth Models." West Conshohocken, Pennsylvania, US: ASTM International, 2013.
- [2] M.E. Kim and N. Dembsey, "Engineering Guide for Estimating Material Pyrolysis Properties for Fire Modeling," Worcester Polytechnic Institute, Worcester, Massachusetts, US2012.
- [3] EN 13501-2, "Fire classification of construction products and building elements - Part 2: Classification using data from fire resistance tests, excluding ventilation services," European Standard, 2016.
- [4] ISO 1716, "Reaction to fire tests for products — Determination of the gross heat of combustion (calorific value)." Geneva, Switzerland: International Standards Organization (ISO), 2010.
- [5] A.W. Coats and J.P. Redfern, "Thermogravimetric analysis. A review," *Analyst*, vol. 88, pp. 906-924, 1963.
- [6] R.E. Lyon, N. Safronava, J. Senese, and S.I. Stoliarov, "Thermokinetic model of sample response in nonisothermal analysis," *Thermochimica Acta*, vol. 545, pp. 82-89, 2012.
- [7] ASTM D2395-17, "Standard Test Methods for Density and Specific Gravity (Relative Density) of Wood and Wood-Based Materials." West Conshohocken, Pennsylvania, US: ASTM International, 2014.
- [8] L. De Chiffre, S. Carmignato, J.P. Kruth, R. Schmitt, and A. Weckenmann, "Industrial applications of computed tomography," *CIRP Annals*, vol. 63, pp. 655-677, 2014.
- [9] J. Geng, "Structured-light 3D surface imaging: a tutorial," *Advances in Optics and Photonics*, vol. 3, pp. 128-160, 2011.
- [10] D. Lázaro, M. Lázaro, A. Alonso, and D. Alvear, "Effects of boundary conditions variation on chemical reactions during STA measurements," in *International conference on research and advanced technology fire safety*, Santander, 2017, pp. 347-357.
- [11] B. Wunderlich, "Thermomechanical Analysis and Dilatometry," in *Thermal Analysis*, ed: Elsevier Science, 2012.
- [12] ISO 5660-1, "Reaction-to-fire tests -- Heat release, smoke production and mass loss rate -- Part 1: Heat release rate (cone calorimeter method) and smoke production rate (dynamic measurement)." Geneva, Switzerland: International Standards Organization (ISO), 2015.
- [13] ISO 12136, "Reaction to fire tests -- Measurement of material properties using a fire propagation apparatus." Geneva, Switzerland: International Standards Organization (ISO), 2011.
- [14] ASTM E1321-13, "Standard Test Method for Determining Material Ignition and Flame Spread Properties." West Conshohocken, Pennsylvania, US: ASTM International, 2013.
- [15] H.E. Thomson, D.D. Drysdale, and C.L. Beyler, "An experimental evaluation of critical surface temperature as a criterion for piloted ignition of solid fuels," *Fire Safety Journal*, vol. 13, pp. 185-196, 1988.
- [16] G. Rein, "Smoldering Combustion," in *SFPE Handbook of Fire Protection Engineering*, M. J. Hurley, D. Gottuk, J. R. Hall, K. Harada, E. Kuligowski, M. Puchovsky, et al., Eds., ed New York: Springer New York, 2016, pp. 581–603.
- [17] A. Atreya, *Pyrolysis, Ignition and Fire Spread on Horizontal Surfaces of Wood*: Harvard University, 1983.

- [18] I. Vermesi, N. Roenner, P. Pironi, R.M. Hadden, and G. Rein, "Pyrolysis and ignition of a polymer by transient irradiation," *Combustion and Flame*, vol. 163, pp. 31-41, 2016.
- [19] W.C. Park, A. Atreya, and H.R. Baum, "Determination of pyrolysis temperature for charring materials," *Proceedings of the Combustion Institute*, vol. 32, pp. 2471-2479, 2009.
- [20] B. Mi, Z. Liu, W. Hu, P. Wei, Z. Jiang, and B. Fei, "Investigating pyrolysis and combustion characteristics of torrefied bamboo, torrefied wood and their blends," *Bioresource Technology*, vol. 209, pp. 50-55, 2016.
- [21] ISO 8301, "Thermal insulation -- Determination of steady-state thermal resistance and related properties -- Heat flow meter apparatus." Geneva, Switzerland: International Standards Organization (ISO), 2014.
- [22] R. Jansson, "Measurement of thermal properties at elevated temperatures," SP Report 2004:46, SP Swedish National Testing and Research Institute, Borås, Sweden 2004.
- [23] ISO 22007-2, "Plastics -- Determination of thermal conductivity and thermal diffusivity -- Part 2: Transient plane heat source (hot disc) method." Geneva, Switzerland: International Standards Organization (ISO), 2015.
- [24] ISO 8302, "Thermal insulation -- Determination of steady-state thermal resistance and related properties -- Guarded hot plate apparatus." Geneva, Switzerland: International Standards Organization (ISO), 2014.
- [25] ISO 11357-1, "Plastics -- Differential scanning calorimetry (DSC) -- Part 1: General principles." Geneva, Switzerland: International Standards Organization (ISO), 2016.
- [26] S.-D. Clas, C.R. Dalton, and B.C. Hancock, "Differential scanning calorimetry: applications in drug development," *Pharmaceutical Science & Technology Today*, vol. 2, pp. 311-320, 1999.
- [27] D.I. Kolaitis and M.A. Founti, "Development of a solid reaction kinetics gypsum dehydration model appropriate for CFD simulation of gypsum plasterboard wall assemblies exposed to fire," *Fire Safety Journal*, vol. 58, pp. 151-159, 2013.
- [28] M. Chaos, "Spectral aspects of bench-scale flammability testing: application to hardwood pyrolysis," *Fire Safety Science*, vol. 11, pp. 165-178, 2014.
- [29] ASTM E1591-13, "Standard Test Methods for Total Normal Emittance of Surfaces Using Inspection-Meter Techniques." West Conshohocken, Pennsylvania, US: ASTM International, 2013.
- [30] ISO 16378, "Space systems -- Measurements of thermo-optical properties of thermal control materials." Geneva, Switzerland: International Standards Organization (ISO), 2013.
- [31] ASTM C835-06(2013)e1, "Standard Test Method for Total Hemispherical Emittance of Surfaces up to 1400°C." West Conshohocken, Pennsylvania, US: ASTM International, 2013.
- [32] ISO 13061-1, "Physical and mechanical properties of wood -- Test methods for small clear wood specimens -- Part 1: Determination of moisture content for physical and mechanical tests." Geneva, Switzerland: International Standards Organization (ISO), 2014.
- [33] ASTM D4442-16, "Standard Test Methods for Direct Moisture Content Measurement of Wood and Wood-Based Materials." West Conshohocken, Pennsylvania, US: ASTM International, 2016.
- [34] EN 13238, "Reaction to fire tests for building products - Conditioning procedures and general rules for selection of substrates," European Standard, 2010.
- [35] ASTM D7438-13, "Standard Practice for Field Calibration and Application of Hand-Held Moisture Meters." West Conshohocken, Pennsylvania, US: ASTM International, 2013.

- [36] D.F. Arseneau, "Competitive Reactions in the Thermal Decomposition of Cellulose," *Canadian Journal of Chemistry*, vol. 49, pp. 632-638, 1971.
- [37] A. Atreya and H.R. Baum, "A model of opposed-flow flame spread over charring materials," *Proceedings of the Combustion Institute*, vol. 29, pp. 227-236, 2002.
- [38] M. Sibulkin, "Heat Of Gasification For Pyrolysis Of Charring Materials," *Fire Safety Science*, vol. 1, pp. 391-400, 1986.
- [39] A. Tewarson and R.F. Pion, "Flammability of plastics—I. Burning intensity," *Combustion and Flame*, vol. 26, pp. 85-103, 1976.
- [40] K. McGrattan, R. McDermott, J. Floyd, S. Hostikka, G. Forney, and H. Baum, "Computational fluid dynamics modelling of fire," *International Journal of Computational Fluid Dynamics*, vol. 26, pp. 349-361, 2012.
- [41] Y. Wang, P. Chatterjee, and J.L. de Ris, "Large eddy simulation of fire plumes," *Proceedings of the Combustion Institute*, vol. 33, pp. 2473-2480, 2011.
- [42] M. Chaos, M.M. Khan, N. Krishnamoorthy, J.L. de Ris, and S.B. Dorofeev, "Evaluation of optimization schemes and determination of solid fuel properties for CFD fire models using bench-scale pyrolysis tests," *Proceedings of the Combustion Institute*, vol. 33, pp. 2599-2606, 2011.
- [43] V. Babrauskas and R.D. Peacock, "Heat release rate: The single most important variable in fire hazard," *Fire Safety Journal*, vol. 18, pp. 255-272, 1992.
- [44] ASTM-E1537-16, "Standard Test Method for Fire Testing of Upholstered Furniture." West Conshohocken, Pennsylvania, US: ASTM International, 2015.
- [45] H. Clayton, "Estimation of rate of heat release by means of oxygen consumption measurements," *Fire and Materials*, vol. 4, pp. 61-65, 1980.
- [46] ISO 17247, "Coal -- Ultimate analysis." Geneva, Switzerland: International Standards Organization (ISO), 2013.
- [47] ISO 5659-2, "Plastics -- Smoke generation -- Part 2: Determination of optical density by a single-chamber test." Geneva, Switzerland: International Standards Organization (ISO), 2017.
- [48] ISO 19702, "Guidance for sampling and analysis of toxic gases and vapours in fire effluents using Fourier Transform Infrared (FTIR) spectroscopy." Geneva, Switzerland: International Standards Organization (ISO), 2015.
- [49] ISO 5658-2, "Reaction to fire tests -- Spread of flame -- Part 2: Lateral spread on building and transport products in vertical configuration." Geneva, Switzerland: International Standards Organization (ISO), 2006.
- [50] ISO 5658-4, "Reaction to fire tests — Spread of flame — Part 4: Intermediate-scale test of vertical spread of flame with vertically oriented specimen." Geneva, Switzerland: International Standards Organization (ISO), 2001.
- [51] EN 13823, "Reaction to fire tests for building products - Building products excluding floorings exposed to the thermal attack by a single burning item," European Standard, 2014.
- [52] CEN/TS-1187, "Test methods for external fire exposure to roofs," European Standard, 2012.
- [53] ISO 9239-1, "Reaction to fire tests for floorings -- Part 1: Determination of the burning behaviour using a radiant heat source." Geneva, Switzerland: International Standards Organization (ISO), 2010.

- [54] ISO 9705-1, "Reaction to fire tests -- Room corner test for wall and ceiling lining products -- Part 1: Test method for a small room configuration." Geneva, Switzerland: International Standards Organization (ISO), 2016.
- [55] S. Vyazovkin, K. Chrissafis, M.L. Di Lorenzo, N. Koga, M. Pijolat, B. Roduit, *et al.*, "ICTAC Kinetics Committee recommendations for collecting experimental thermal analysis data for kinetic computations," *Thermochimica Acta*, vol. 590, pp. 1-23, 2014.
- [56] E.-R.-A. 8, "Test to determine the vertical burning rate of material," European Standard, 2012.
- [57] L.D. Tsantaridis and B.A.-L. Östman, "Charring of protected wood studs," *Fire and Materials*, vol. 22, pp. 55-60, 1998.
- [58] V. Babrauskas, "Charring rate of wood as a tool for fire investigations," *Fire Safety Journal*, vol. 40, pp. 528-554, 2005.
- [59] T. Harada, S. Uesugi, and H. Masuda, "Fire resistance of thick wood-based boards," *Journal of Wood Science*, vol. 52, pp. 544-551, 2006.
- [60] J. Liblik and A. Just, "Design parameters for timber members protected by clay plaster at elevated temperatures," in *Proceedings of International Network on Timber Engineering Research (INTER), Meeting 50*, Kyoto, Japan, 2017, pp. 375-389.
- [61] J. Liblik and A. Just, "Performance of Constructions with Clay Plaster and Timber at Elevated Temperatures," *Energy Procedia*, vol. 96, pp. 717-728, 2016.
- [62] ISO 834-11, "Fire resistance tests -- Elements of building construction -- Part 11: Specific requirements for the assessment of fire protection to structural steel elements." Geneva, Switzerland: International Standards Organization (ISO), 2014.
- [63] R.M. Hadden, A.I. Bartlett, J.P. Hidalgo, S. Santamaria, F. Wiesner, L.A. Bisby, *et al.*, "Effects of exposed cross laminated timber on compartment fire dynamics," *Fire Safety Journal*, vol. 91, pp. 480-489, 2017.
- [64] B. ScharTEL, M. Bartholmai, and U. Knoll, "Some comments on the use of cone calorimeter data," *Polymer Degradation and Stability*, vol. 88, pp. 540-547, 2005.
- [65] C. Maluk, L. Bisby, M. Krajcovic, and J.L. Torero, "A Heat-Transfer Rate Inducing System (H-TRIS) Test Method," *Fire Safety Journal*, 2016.
- [66] C. Gengnagel, A. Pfriend, T. Brodhagen, and M. Obladen, "Development of facade elements with pyrolysed surface with improved fire protection properties: PyroForCE (Pyrolysis For Construction Elements)," FNR project final report (in German), Berlin University of the Arts, Institute for Architecture and Urban Design.2017.
- [67] W.Ł. Grzeńkowiak and T. Wińniewski, "Fire safety of fireplaces - wood based products speed of charring," *Annals of Warsaw University of Life Sciences - SGGW, Forestry and Wood Technology*, pp. 229-234, 2010.
- [68] ASTM E69-15, "Standard Test Method for Combustible Properties of Treated Wood by the Fire-Tube Apparatus." West Conshohocken, Pennsylvania, US: ASTM International, 2015.
- [69] W.Ł. Grzeńkowiak, "Effectiveness of new wood fire retardants using a cone calorimeter," *Journal of Fire Sciences*, vol. 35, pp. 565-576, 2017.
- [70] ISO 4589-1, "Plastics -- Determination of burning behaviour by oxygen index -- Part 1: General requirements." Geneva, Switzerland: International Standards Organization (ISO), 2017.
- [71] A.P. Mouritz and A.G. Gibson, *Fire Properties of Polymer Composite Materials*. Netherlands: Springer, 2006.

- [72] S. Liodakis, T. Kakardakis, S. Tzortzakou, and V. Tsapara, "How to measure the particle ignitability of forest species by TG and LOI," *Thermochimica Acta*, vol. 477, pp. 16-20, 2008.
- [73] R.H. White, "Oxygen index evaluation of fire-retardant-treated wood," *Wood science*, vol. 12, pp. 113-121, 1979.
- [74] A. Donmez Cavdar, F. Mengeloğlu, and K. Karakus, "Effect of boric acid and borax on mechanical, fire and thermal properties of wood flour filled high density polyethylene composites," *Measurement*, vol. 60, pp. 6-12, 2015.
- [75] A. Donmez Cavdar, H. Kalaycioglu, and F. Mengeloğlu, "Technological properties of thermoplastic composites filled with fire retardant and tea mill waste fiber," *Journal of Composite Materials*, vol. 50, pp. 1627-1634, 2016.
- [76] ASTM D2863-17, "Standard Test Method for Measuring the Minimum Oxygen Concentration to Support Candle-Like Combustion of Plastics (Oxygen Index)." West Conshohocken, Pennsylvania, US: ASTM International, 2017.
- [77] A.D. Cavdar, E.D. Tomak, and H. Kalaycioglu, "The Determination with Oxygen Index of Fire Properties of Boric Acid Treated Particleboards," in *National Boron Workshop*, 2008, pp. 251-257.
- [78] D. Zeinali, S. Verstockt, T. Beji, G. Maragkos, J. Degroote, and B. Merci, "Experimental study of corner fires—Part II: Flame spread over MDF panels," *Combustion and Flame Journal*, vol. 189, pp. 491–505, 2018.
- [79] D.J. Hopkin, "The Fire Performance of Engineered Timber Products and Systems," Doctoral Thesis, Department of Civil and Building, Engineering Loughborough University, UK, 2017.
- [80] E.K. Asimakopoulou, D.I. Kolaitis, and M.A. Founti, "Fire safety aspects of PCM-enhanced gypsum plasterboards: An experimental and numerical investigation," *Fire Safety Journal*, vol. 72, pp. 50-58, 2015.
- [81] R. Crielaard, "Self-Extinguishment of Cross-Laminated Timber," Master's Thesis, Faculty of Civil Engineering and Geosciences, Netherlands, Delft University of Technology, 2015.
- [82] R. Hadden, A. Bartlett, J. Hidalgo, S. Santamaria, F. Wiesner, L. Bisby, *et al.*, "Effects of Exposed Engineered Timber on Compartment Fire Dynamics," in *Proceedings of the 12th International Association of Fire Safety Science Symposium*, Lund, Sweden, 2017.
- [83] A. Bartlett, R. Hadden, L. Bisby, and A. Law, "Analysis of Cross-Laminated Timber Charring Rates upon Exposure to Non-Standard Heating Conditions," in *Proceedings of the 14th International Conference on Fire and Materials*, San Francisco, US, 2015.
- [84] C.P. Butler, "Notes on Charring Rates in Wood," *Fire Research Notes*, vol. 896, 1971.
- [85] V. Babrauskas, "Wood Char Depth: Interpretation in Fire Investigations," in *International Symposium on Fire Investigation*, Moreton-in-Marsh, UK, 2004.
- [86] K.L. Friquin, M. Grimsbu, and P.J. Hovde, "Charring rates for cross-laminated timber panels exposed to standard and parametric fires," in *World Conference on Timber Engineering*, Trentino, Italy, 2010, pp. 3856 - 3865.
- [87] A. Bartlett, F. Wiesner, R. Hadden, L. Bisby, B. Lane, A. Lawrence, *et al.*, "Needs for total fire engineering of mass timber buildings," in *Proceedings of the World Conference on Timber Engineering*, Vienna, Austria, 2016, pp. 3856 - 3865.
- [88] E. Mikkola, "Charring of wood," Fire Technology Laboratory, Technical Research Center of Finland, Research Reports 689, Espoo, Finland 1990.

- [89] E. Kim and N. Dembsey, "Parameter Estimation for Comprehensive Pyrolysis Modeling: Guidance and Critical Observations," *Fire Technology*, vol. 51, pp. 443-477, 2015.
- [90] N. Bal and G. Rein, "Relevant model complexity for non-charring polymer pyrolysis," *Fire Safety Journal*, vol. 61, pp. 36-44, 2013.
- [91] H. Wang and D.A. Sheen, "Combustion kinetic model uncertainty quantification, propagation and minimization," *Progress in Energy and Combustion Science*, vol. 47, pp. 1-31, 2015.
- [92] I. Vermesi, M.J. DiDomizio, F. Richter, E.J. Weckman, and G. Rein, "Pyrolysis and spontaneous ignition of wood under transient irradiation: Experiments and a-priori predictions," *Fire Safety Journal*, vol. 91, pp. 218-225, 2017.
- [93] O. Takeo, "A New Method of Analyzing Thermogravimetric Data," *Bulletin of the Chemical Society of Japan*, vol. 38, pp. 1881-1886, 1965.
- [94] V. Sergey, "Evaluation of activation energy of thermally stimulated solid-state reactions under arbitrary variation of temperature," *Journal of Computational Chemistry*, vol. 18, pp. 393-402, 1997.
- [95] V. Sergey, "Modification of the integral isoconversional method to account for variation in the activation energy," *Journal of Computational Chemistry*, vol. 22, pp. 178-183, 2001.
- [96] H.E. Kissinger, "Reaction Kinetics in Differential Thermal Analysis," *Analytical Chemistry*, vol. 29, pp. 1702-1706, 1957.
- [97] D. Lázaro, M. Lázaro, A. Alonso, and D. Alvear, "Effects of variation in sample mass, gas flow and lid on chemical reactions during STA measurements," in *26th International Colloquium on the Dynamics of Explosions and Reactive Systems*, Boston, 2017, pp. 1-6.
- [98] P. Girods, H. Bal, H. Bateau, G. Rein, and J.L. Torero, "Comparison of Pyrolysis Behavior Results between the Cone Calorimeter and the Fire Propagation Apparatus Heat Sources," *Fire Safety Science*, vol. 10, pp. 889-901, 2011.
- [99] F. Richter and G. Rein, "Pyrolysis kinetics and multi-objective inverse modelling of cellulose at the microscale," *Fire Safety Journal*, vol. 91, pp. 191-199, 2017.
- [100] X. Huang, K. Li, and H. Zhang, "Modelling bench-scale fire on engineered wood: Effects of transient flame and physicochemical properties," *Proceedings of the Combustion Institute*, vol. 36, pp. 3167-3175, 2017.
- [101] N. Bal and G. Rein, "On the effect of inverse modelling and compensation effects in computational pyrolysis for fire scenarios," *Fire Safety Journal*, vol. 72, pp. 68-76, 2015.
- [102] S.I. Stoliarov and J. Li, "Parameterization and Validation of Pyrolysis Models for Polymeric Materials," *Fire Technology*, vol. 52, pp. 79-91, 2016.
- [103] K. McGrattan, S. Hostikka, R. McDermott, J. Floyd, C. Weinschenk, and K. Overholt, "Fire Dynamics Simulator User's Guide (Sixth Edition), FDS Version 6.5.1," National Institute of Standards and Technology (NIST)2016.
- [104] C.F. Dickinson and G.R. Heal, "A review of the ICTAC Kinetics Project, 2000: Part 1. Isothermal results," *Thermochimica Acta*, vol. 494, pp. 1-14, 2009.
- [105] C.F. Dickinson and G.R. Heal, "A review of the ICTAC kinetics project, 2000: Part 2. Non-isothermal results," *Thermochimica Acta*, vol. 494, pp. 15-25, 2009.
- [106] G. Agarwal, M. Chaos, Y. Wang, D. Zeinali, and B. Merci, "Pyrolysis Model Properties of Engineered Wood Products and Validation Using Transient Heating Scenarios," presented at the 14th International Conference and Exhibition on Fire Science and Engineering, Royal Holloway College, Nr Windsor, UK, 2016.

- [107] D. Zeinali, G. Agarwal, A. Gupta, G. Maragkos, N. Ren, M. Chaos, *et al.*, "Computational Analysis of Pyrolysis and Flame Spread for MDF Panels Placed in a Corner Configuration," in *the 8th International Seminar on Fire and Explosion Hazards*, Hefei, China, 2016.
- [108] G. Rein, J.L. Torero, W. Jahn, J. Stern-Gottfried, N.L. Ryder, S. Desanghere, *et al.*, "Round-robin study of a priori modelling predictions of the Dalmarnock Fire Test One," *Fire Safety Journal*, vol. 44, pp. 590-602, 2009.
- [109] C. Lautenberger, G. Rein, and C. Fernandez-Pello, "The application of a genetic algorithm to estimate material properties for fire modeling from bench-scale fire test data," *Fire Safety Journal*, vol. 41, pp. 204-214, 2006.
- [110] Z. Ghorbani, R. Webster, M. Lázaro, and A. Trouvé, "Limitations in the predictive capability of pyrolysis models based on a calibrated semi-empirical approach," *Fire Safety Journal*, vol. 61, pp. 274-288, 2013.
- [111] G. Rein, C. Lautenberger, A.C. Fernandez-Pello, J.L. Torero, and D.L. Urban, "Application of genetic algorithms and thermogravimetry to determine the kinetics of polyurethane foam in smoldering combustion," *Combustion and Flame*, vol. 146, pp. 95-108, 2006.
- [112] A. Matala, S. Hostikka, and J. Mangs, "Estimation of pyrolysis model parameters for solid materials using thermogravimetric data," *Fire Safety Science*, vol. 9, pp. 1213-1223, 2008.
- [113] D. Alvear, O. Abreu, M. Lázaro, E. Puente, and D. Lázaro, "Modeling pyrolysis of a thermoplastic using an optimization process of simultaneous thermal analyzer simulations," in *Seventh International Seminar on Fire and Explosion Hazards*, US, 2013, pp. 401-410.
- [114] D. Alvear, J. Capote, M. Lázaro, E. Puente, and D. Lázaro, "Thermoplastic mass loss rate prediction at Cone Calorimeter through a set of parameters obtained by optimization against experimental STA tests," in *International Congress Fire Computer Modeling*, Santander, 2012, pp. 151-160.
- [115] A. Alonso, "Modeling of thermal and kinetic parameters for the characterization of the materials under fire conditions," Doctoral Thesis, Department of Fire Safety Engineering, University of Cantabria, Spain, 2017.
- [116] L. Hasalová, J. Ira, and M. Jahoda, "Practical observations on the use of Shuffled Complex Evolution (SCE) algorithm for kinetic parameters estimation in pyrolysis modeling," *Fire Safety Journal*, vol. 80, pp. 71-82, 2016.
- [117] M. Chaos, M. Khan, N. Krishnamoorthy, J.d. Ris, and S. Dorofeev, "Bench-scale flammability experiments: determination of material properties using pyrolysis models for use in CFD fire simulations," in *Proceedings of the twelfth international Interflam conference*, UK, 2010, pp. 697-708