

Thermal, electromagnetic and structural analysis of gas baffles for the TCV divertor upgrade[☆]

Dario Vaccaro^{a,b,*}, H. Elaian^b, H. Reimerdes^b, M. Baquero^b, B.P. Duval^b, D. Marzullo^c, J.-M. Moret^b, C. Theiler^b, G. Calabrò^a, G. Di Gironimo^c, P. Fanelli^a, S. Minucci^a, A. Salvitti^a, M. Toussaint^b, the TCV team¹

^a Department of Economics, Engineering, Society and Business Organization (DEIm) University of Tuscia Largo dell'Università snc, 01100, Viterbo, Italy

^b Ecole Polytechnique Fédérale de Lausanne (EPFL), Swiss Plasma Center (SPC), 1015, Lausanne, Switzerland

^c Consorzio di Ricerca per l'Energia, l'Automazione e le Tecnologie dell'Elettromagnetismo (CREATE), Dipartimento di Ingegneria Industriale (DII), University of Naples Federico II, 80125, Naples, Italy

As part of an ongoing divertor upgrade of the TCV tokamak it is planned to add gas baffles to form a divertor chamber of variable closure. The baffles promise to increase the compression of neutral particles in the divertor and, thereby, extend the research on the TCV divertor towards more reactor relevant, highly dissipative divertor regimes. It is foreseen to construct the baffles entirely of polycrystalline graphite that was used for the existing TCV protection tiles. The thermal considerations of the baffle design are based on the heat loads expected during normal operation, where even an extremely large increase in the power carrying plasma channel towards the baffle over the entire 2 seconds duration of a TCV discharge gives no cause for concern. An electromagnetic analysis considers halo currents flowing through the baffles, which can occur during disruptions, as a worst-case scenario. It is found that a halo current of 250 kA results in an average vertical force in the baffles of up to 950 kN/m³. The fixture of the baffle tiles to the vacuum vessel is designed for a maximum tensile stress of 31 MPa and maximum compressive stress of 60 MPa that remains a factor of two below their respective material limits. The obtained results of the thermal, electromagnetic and structural analysis thus validate the proposed baffle design.

1. Introduction

The primary objective of the ongoing upgrade of the TCV tokamak [1,2] is to extend divertor research on TCV towards more reactor relevant, highly dissipative divertor regimes. The current plan is to add gas baffles on the inner and outer vessel walls and, thereby, convert the present open TCV vessel into a main chamber and a separate, relatively closed, divertor chamber. The baffles promise to increase the compression of neutral particles in the divertor and, thereby, enhance the dissipation of energy and momentum in the divertor.

The envisaged baffle closure is guided by divertor plasma simulations, which predict an optimum closure for divertor performance [2]. However, to mitigate any risk that these simulations may contain significant errors, the upgrade project includes the option to iterate the baffle design after an initial version has been tested. It should also

remain possible to exchange the baffles to temporarily restore the present, full shaping capability of TCV. Both considerations led to a flexible design solution based on easily removable graphite tiles, described in section 2. To validate that the proposed design is compatible with the expected thermal, electromagnetic and mechanical stresses, a numerical model of the tile is developed in section 3. The thermal, electromagnetic and structural analysis are subsequently shown in sections 4,5 and 6. Section 7 discusses the particular issues that arise from a thermal bake of the device before summarising in section 8.

2. Design solution

The TCV divertor gas baffle will be constructed from a large number of segments that are easy to handle and made entirely of high purity polycrystalline graphite, also used for the present protection tiles in

[☆] See author list of S. Coda et al 2017 Nucl. Fusion 57 102011

* Corresponding author.

E-mail address: dario.vaccaro@epfl.ch (D. Vaccaro).

¹ See author list of S. Coda et al 2017 Nucl. Fusion 57 102011

TCV [3]. The vessel will be equipped with 32 of such baffle tiles on the inner wall and with 64 baffle tiles on the outer wall, with each baffle tile replacing an existing protection tile. Each baffle tiles will be installed with a single screw to existing welded rails. The tiles are separated in the toroidal direction by 2 mm gaps. The tiles are not actively cooled and the heat deposited during a typical two second TCV plasma discharge is exhausted in between discharges via the thermal contact with the rail. Key points of the baffle design are the surface exposed to the main plasma and the attachment to the vacuum vessel.

2.1. Exposed region

The baffle will be exposed to radiation, neutral and charged particle fluxes. While radiation and neutral fluxes are isotropic, charged particles follow magnetic field lines and can lead to large localised heat loads and significant heating of the tile surface. At a temperature of 2200 K the graphite starts to sublimate, which pollutes the plasma with carbon (C). The resulting C radiation limits the heat flux to the surface, but will severely perturb the experiment or cause a disruption. While sublimation must be avoided during routine operation, carbon self-protects the integrity of the tile in the case of off-normal events.

In the standard diverted TCV configuration only magnetic field lines of the far scrape-off layer (SOL) intercept the tips of the baffles, Fig. 1(a). Due to the exponential decay of the plasma heat flux along the magnetic field lines in the SOL, Fig. 1(b), and the shallow grazing angle of the field line at the baffle, γ , the heat flux onto a toroidally symmetric baffle is low, Fig. 1(c,d), and pose no reason for concern.

However, local heat fluxes in a 3D geometry with inevitable tile gaps and apertures for diagnostics can increase dramatically as the incidence increases from a few degrees to perpendicular. Avoiding the exposure of leading edges requires a tile design with set-backs, which are determined by the largest admissible grazing angle of field lines, γ_{\max} . To maintain compatibility with both magnetic field helicities, the tiles have a symmetry plane.

The most severe constraints on the set-back is imposed by apertures that are required for key diagnostics. Foreseen are apertures for several interferometer chords, edge views of the Thomson scattering diagnostic and edge chords of the charge exchange recombination diagnostic. The proposed design allows for apertures that are as wide as an entire tile,

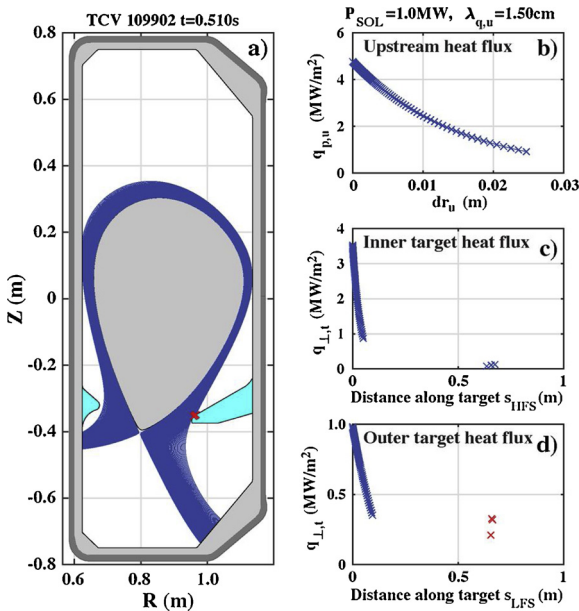

Fig. 1. (a) Diverted TCV configuration with (b) an assumed extremely broad heat flux profile at the outboard midplane and the resulting heat fluxes onto the (c) inner and (d) outer target.

Fig. 2, which requires a set-back,

$$D_{\text{set-back}} = (3/2D_{\text{tile}} + 2D_{\text{gap}})\tan\gamma_{\max}$$

corresponding to a chamfering angle,

$$\alpha_{\text{cham}} = \text{atan}\left(\frac{D_{\text{set-back}}}{D_{\text{tile}}/2}\right)$$

Based on an assumed largest grazing angle of $\gamma_{\max} = 3.5^\circ$ and adding some safety margin a chamfering angle $\alpha_{\text{cham}} = 12^\circ$ is chosen. While such a chamfering angle also increase the peak heat load with respect to the axisymmetric case assumed in Fig. 1 by a factor of ~ 4 , the expected values remain far below critical values.

2.2. Attachment

The baffle tiles will be attached to existing rails that are welded to the vacuum vessel through an assembly of components, similar to the one used for the present central column tiles [3]. This is achieved by a titanium screw combined with a titanium plate and a stainless steel-316L tube allocated in a machined pocket inside of each baffle tile, Fig. 3. The attachment geometry distributes stresses (e.g. during disruptions) over a large surface area.

3. Model definition

The CAD model is composed of the baffle, a screw, a plate, a tube and the welded rail, Fig. 4.

3.1. Thermal and structural mesh specifications

The thermal and structural analyses use the same mesh to facilitate coupling. All parts are meshed using a hex dominant method and a face sizing of 2 mm. At the interfaces of components the mesh is manually improved with face sizing of 0.5 mm.

3.2. Electromagnetic mesh specifications

The electromagnetic analysis uses the static solver adaptive mesh technique of ANSYS Maxwell. The *Imported load transfer summary* of ANSYS Structural shows the perfect adaptability with the input.

4. Thermal analysis

The thermal analysis of the baffles is carried out for the heat loads expected during normal operation. The heat flux onto the surface elements of the mesh is provided by a MATLAB routine and the temperature evolution simulated with the Transient Thermal Analysis module of ANSYS Workbench 18.1. The heat load distribution is imported into ANSYS transient thermal analysis via an external data component system. The external load is imported by switching the mapping control to *manual* and setting the weighting and the number of points on *Distance Based Average* and *1*, respectively. The heat flux surface distribution is shown in Fig. 5(a). During normal operation the maximum value of the imported heat flux is 1.63 MW/m². The heat flux reaches only a small part of the baffle surface, since most of the tile surface is in the shadows of the wall or the adjacent baffle tile.

The application of the heat flux for two seconds, which corresponds to a typical TCV plasma discharge, is predicted to result in a temperature increase from room temperature (295 K) to a maximum value of 435 K, which is far below the graphite sublimation temperature of 2200 K, Fig. 5(b). The thermal analysis thereby shows that heat fluxes during normal operation are expected to be well within the tolerable range.

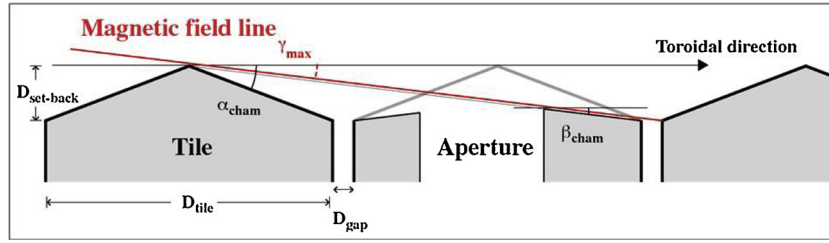

Fig. 2. Set-back of tiles $D_{set-back}$ is determined by largest grazing angle of field lines γ_{max} and apertures for diagnostics.

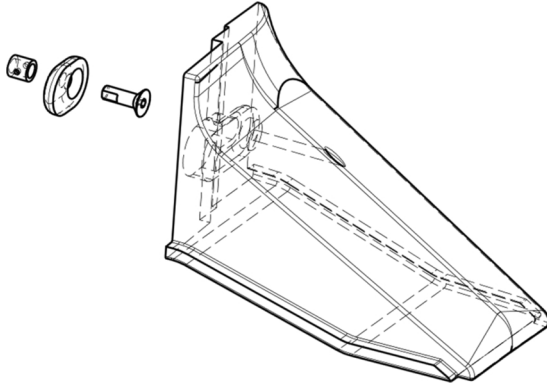

Fig. 3. Illustration of the baffle tile attachment.

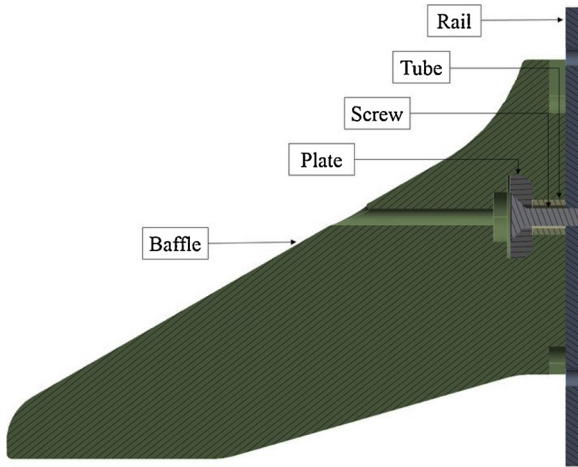

Fig. 4. CAD model assembly.

5. Electromagnetic analysis

The baffles have to withstand electromagnetic forces, which will be largest during disruptions. The geometry of the TCV baffles is particularly prone to halo currents, which can flow through the conducting structure in contact with a disrupting plasma. The magnitude of the halo current can be a significant fraction of the plasma current with local current densities being increased via toroidal peaking. Cross-machine comparison indicated that the product of halo current and toroidal peaking factor is limited to 75% of the plasma current I_p [4]. Considering a maximum $I_p = 340$ kA, the maximum current expected in a single outer baffle tile is 4 kA.

The electromagnetic 3D analysis is carried out using ANSYS Maxwell for stationary conditions. Dynamic effects will be considered in future analysis. The electromagnetic load due to the Lorentz force is calculated for the nominal magnetic field of 1.43 T and a halo current of 4 kA entering the tile at its outer tip. The contact surface between the baffle and the rail is considered perfectly insulated with the entire

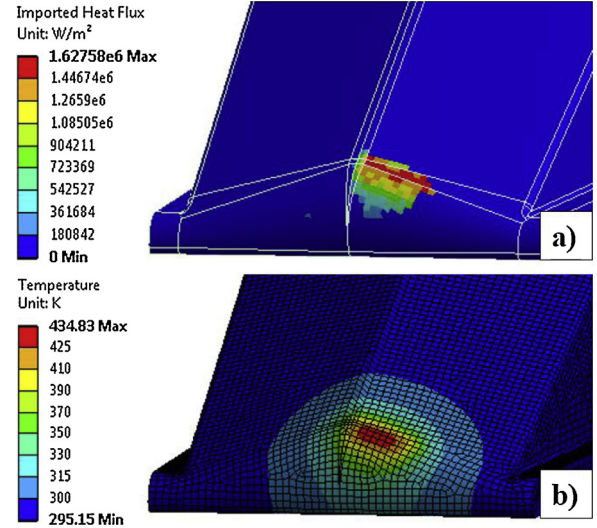

Fig. 5. (a) Imported heat flux for the divertor configuration shown in Fig. 1. (b) Temperature distribution after two seconds of exposure to the heat flux of standard operation.

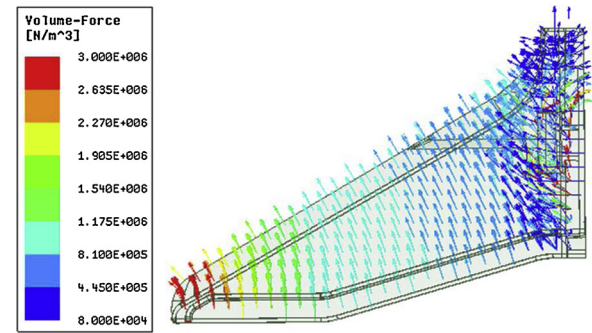

Fig. 6. Force density arising from a toroidal field of 1.43 T and a current of 4 kA flowing from the tile tip to the rail.

current being conducted through the screw. This worst-case scenario results in a dominant force component along the vertical axis with an average force density of 950 kN/m^3 , Fig. 6. The corresponding surface density of 60 kN/m^2 is consistent with initial expectations [1] and can result in a total force of up to 1090 N on a single tile.

6. Structural analysis

The structural analysis is carried out using the Static Structural module of ANSYS Workbench 18.1. Since stresses due to the electromagnetic loads are expected in the vicinity of the attachment of the tile to the rail, they can be analysed independently of thermal stresses, which are localised near the tip of the baffle (see section 4).

The thermal analysis is based on the temperature distribution, which occurs after a two second diverted discharge, Fig. 5(b). The

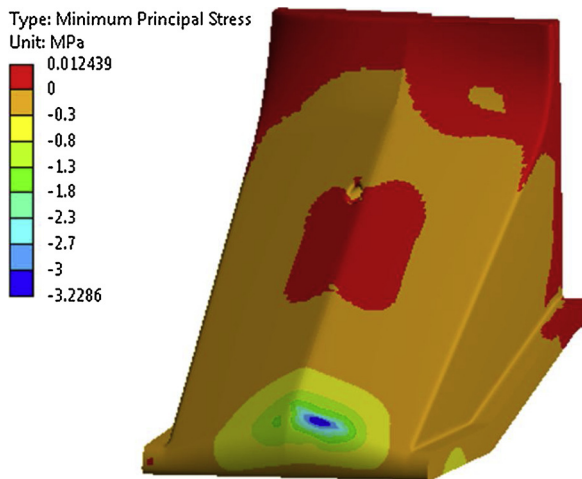

Fig. 7. Minimum principal stress distribution due to the temperature distribution.

Table 1
Maximum and minimum values of principal stresses due to thermal loads.

Principal stress	Maximum value [MPa]	Minimum value [MPa]
Maximum	1.02	-0.2
Middle	0.14	-1.59
Minimum	0.01	-3.23

resulting stress due to thermal gradient are shown in Fig. 7. The maximum and minimum values of principal stresses, Table 1, remain well below the material limits of the graphite used for the tile of 65 MPa and 150 MPa for tensile and compressive stresses, respectively.

The electromagnetic analysis takes into account, volumetric forces due to halo currents, Fig. 6, and a screw preload of 12500 N. The analysis is carried out in two steps. The first one is used to apply the preload and the second to apply the external load with the preload locked. The attachment design with no space between the metal plate and the machined pocket in the graphite tile can avoid shifts and subsequent misalignments. The resulting electromagnetic force, with the main component of 1090 N oriented along the vertical axes, generates a deformation of up to 0.25 mm at the baffle tip, consistent with the available spacing. The resulting stresses are higher in the attachment zone. Peak values on graphite are localised at the interface between the pocket face and the plate, Fig. 8. The study of principal stresses provides maximum values of 30.8 MPa for the tensile stress and 59.4 MPa for the compressive stress, Table 2. These values correspond to safety factors of 2.1 and 2.5, respectively.

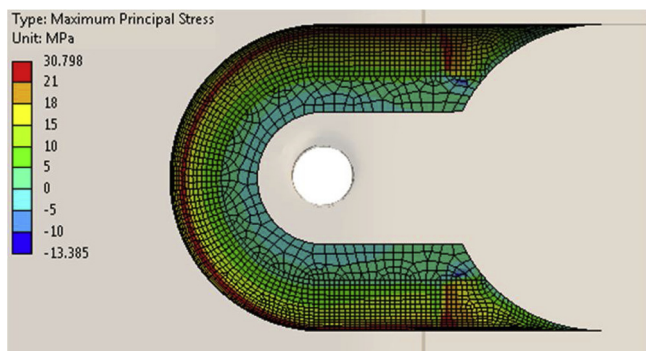

Fig. 8. Maximum principal stress distribution due to electro-magnetic forces and the screw preload.

Table 2
Maximum and minimum values of principal stresses due to electromagnetic loads.

Principal stress	Maximum value [MPa]	Minimum value [MPa]
Maximum	30.8	-13.4
Middle	9.03	-38.05
Minimum	3.04	-59.4

7. Baking simulation

The attachment design foresees no space between the metal plate and the machined pocket in the graphite tile, Fig. 3, to facilitate the spreading of stresses. The attachment must be able to tolerate the baking of the TCV vessel, where the in-vessel components reach a temperature of up to 520 K. To avoid stresses due to thermal expansion, the plate will be made of titanium whose thermal expansion coefficient is of the same order of magnitude as the coefficient of graphite.

The thermal expansion of the assembly during baking operation up to 520 K is calculated using the Static Structural module of ANSYS Workbench 18.1. The principal stress analysis yields maxima of 20 MPa for the tensile stress and of 60 MPa for the compressive stress corresponding to safety factors of 3.25 and 2.5, Table 3.

8. Summary

A design based on graphite tiles for the gas baffle to be installed in the TCV tokamak is presented. Each tile is attached by a single screw to the vessel. The outer baffle tiles feature a symmetric roof-top with a chamfering angle of 12° to shadow the leading edges of apertures for diagnostics in adjacent tiles.

Numerical calculations of the thermal, electro-magnetic and structural response of the gas baffle to the expected harsh environment during tokamak operation validate the proposed design. The thermal analysis shows that, during normal operation, heat loads are much lower than graphite sublimation limits. The electromagnetic analysis of halo currents, which can occur during disruptions, estimated a vertical force of up to 1090 N to a single baffle tile. Structural analysis calculates a baffle deformation which is highest at the tile tip, but compatible with the spacing between adjacent baffles. The maximum stress values are localised at the baffle-plate interface. The proposed design to spread the stress provides a safety margin of over a factor of two. Although plate and baffle are made from different materials, baking simulation showed that the different coefficients of thermal expansion between baffle and plate does not produce stresses that cause concern. In conclusion, the conducted analysis shows that the proposed design is adequate for the predicted thermal and mechanical stresses during tokamak operation.

Acknowledgements

The authors wish to thank R. Chavan, B. Lipschultz and R.A. Pitts for their advice. This work has been carried out within the framework of the EURO fusion Consortium and has received funding from the Euratom research and training programme 2014-2018 under grant agreement No 633053. The views and opinions expressed herein do not necessarily reflect those of the European Commission. This work was

Table 3
Maximum and minimum values of principal stresses due to a thermal bake up to 520 K.

Principal stress	Maximum value [MPa]	Minimum value [MPa]
Maximum	20	12
Middle	10	38
Minimum	4	60

supported in part by the Swiss National Science Foundation.

References

- [1] H. Reimerdes, et al., Nucl. Mater. Energy 12 (2017) 1106.
- [2] A. Fasoli, Heating and in-vessel upgrades of the TCV tokamak, 30th Symposium on Fusion Energy (2018) Sept . 16-21, Giardini Naxos, Italy, P1.69.
- [3] R.A. Pitts, R. Chavan, J.-M. Moret, Nucl. Fusion 39 (1999) 1433.
- [4] ITER Physics Expert Group on Disruptions, Plasma Control, and MHD and ITER Physics Basis Editors, Nucl. Fusion 39 (1999) 2251.