

# A review of power electronics equipment for all-electric ship MVDC power systems

Simone Castellan<sup>a,\*</sup>, Roberto Menis<sup>a</sup>, Alberto Tassarolo<sup>a</sup>, Fabio Luise<sup>b</sup>, Teresa Mazzuca<sup>c</sup>

<sup>a</sup> Department of Engineering & Architecture, University of Trieste, Trieste, Italy

<sup>b</sup> Motors & Generators R&D, Nidec-ASI, Monfalcone, Italy

<sup>c</sup> Italian Navy General Staff, Ship Design Department, Ministry of Defence, Rome, Italy

## ARTICLE INFO

### Keywords:

DC circuit breaker  
DC distribution  
DC generator system  
Medium Voltage DC (MVDC)  
Solid State Transformer (SST)

## ABSTRACT

Medium Voltage DC (MVDC) distribution Power Systems for all-electric ships (AES) can be regarded as functionally composed of three subsystems, namely the power sources, the load centers and the distribution network. Extensive use of power electronics is required for connecting power sources and load centers to the MVDC bus and for protecting the MVDC power system through properly placed DC circuit breakers. In this paper, an overview is given of the power electronics equipment found in the literature and on the market that could be suitable for use in future AES MVDC power systems. Some industrial experiences regarding DC generator systems, energy storage apparatus and solid-state DC circuit breaker prototypes are reported in the paper as examples of state-of-the-art realizations. Different DC/DC converters, which can be employed as solid-state transformers, are also discussed and a structure obtained by combining them is proposed.

## 1. Introduction

Nowadays, the development of power electronics has reached a level that encourages designers to consider the feasibility of DC-distribution power systems in various forms and application fields [1,2]. Some companies offer proven solutions for High Voltage DC (HVDC) transmission systems [3–5]. However, at present few Medium Voltage DC (MVDC) power systems exist and most of them are in a prototyping or experimental stage [6], therefore in this market sector no or very few ready-to-use solutions can be found yet. Nevertheless, both public research centers and R&D units of leading private companies are working in this direction [7–14].

A leading sector for the study and experimentation of MVDC power systems is the marine sector [15], where important investments have been and are being made to develop this technology [16]. At present the Integrated Power System (IPS) [17,18] of largest commercial vessels is characterized by a Medium Voltage AC (MVAC) distribution. A promising solution to improve IPS performance relies on moving from MVAC to MVDC power systems [19,20].

Compared to its MVAC counterpart, MVDC distribution has several advantages [21–24] such as:

- no need for phase angle synchronization of power sources, which simplifies connection and disconnection procedures for power

generation and storage devices of different type and size;

- reducing the size and ratings of on-board switchgear and cables and elimination of bulky low frequency transformers;
- improved management of fault currents, system reconfiguration and power flow in transient and emergency conditions;
- enhanced efficiency thanks to the elimination of reactive current and to the possibility of variable speed prime mover operation;
- removal of frequency constraints from the design and operation of generator sets [25], leading to size and weight reduction for generators and reducing the running cost gap between gas turbines and diesel engines. This can make it more affordable to use gas turbines, which are known to produce much less polluting emissions than diesel engines [26].

Nevertheless, MVDC power systems pose several technical challenges [22–24,27], such as system protection [28] and network stability [29,30], and further development of industrial equipment for MVDC applications is needed in order for the transition to MVDC shipboard power systems to become a significant reality [31].

Actually, the convenience to use a MVDC distribution depends on the availability of three key components: reliable and efficient power sources, high power DC/DC converters with acceptable cost and efficiency to be employed as Solid State Transformers (SST) [32] (namely power converter systems serving the same purpose as power

\* Corresponding author at: Department of Engineering & Architecture, University of Trieste, Via A. Valerio, 10, 34127 Trieste, Italy.  
E-mail address: scastellan@units.it (S. Castellan).

## Nomenclature

HVDC	High Voltage Direct Current
MVDC	Medium Voltage Direct Current
MVAC	Medium Voltage Alternating Current
LVDC	Low Voltage Direct Current
LVAC	Low Voltage Alternating Current
SST	Solid State Transformer
AES	All-Electric Ship

IPS	Integrated Power System
CB	Circuit Breaker
WRSM	Wound Rotor Synchronous Machine
PMSM	Permanent Magnet Synchronous Machine
VSC	Voltage-Source Converter
NPC	Neutral-Point-Clamped
MMC	Modular Multilevel Converter
MMDC	Modular Multilevel DC/DC Converter
PETT	Power Electronic Traction Transformer

transformer in AC grids, i.e. to adapt voltage levels and ensure galvanic isolation) and protection systems against short circuits, which are much more critical than in AC systems mainly because it is not possible to take advantage of zero crossings for current interruption [33].

Unlike their MVAC counterpart, MVDC power systems require the extensive use of power electronics to connect power sources and loads to the MVDC bus and to provide system protection. In particular, the employment of power electronics equipment in MVDC power systems of All-Electric Ships (AES) is required for: (1) rectifying the AC generator output voltage and realize the shore power interface, (2) connecting the energy storage systems to the MVDC distribution system, (3) supplying the large MV loads, namely propulsion drives, pulse loads and dedicated high power loads, (4) connecting the low-voltage ship service units to the MVDC bus by means of SSTs, (5) realizing fast solid-state and hybrid DC circuit breakers (CB).

Main requirements for the above mentioned power electronic equipment are dependability, functional safety [34,35], compact design and high efficiency [21]. Fulfilling these requirements is becoming more feasible today thanks to the advances in power electronics suitable for shipboard applications [36]. As an additional specification, power converters should have fault current limiting capabilities [21] in order to support system protection and therefore limit the number of DC CBs. Furthermore, power converters connecting loads or power sources with independent grounds to the MVDC bus are required to include a high frequency transformer [21].

In this paper, an overview is given of the power electronics equipment found in the literature and on the market that could be suitable for employment as parts of a future AES MVDC power system. The paper is mainly focused on power electronics equipment tailored to the specific requirements of shipboard MVDC power systems. A particular attention is paid to DC power sources, SSTs and DC CBs, which are key elements requiring a specific design. Some industrial R&D experiences with DC power generator systems, energy storage systems and solid-state DC CBs

are reported in the paper. Different DC/DC converters found in the literature to be employed as SSTs are discussed and a SST layout obtained by combining some of the main described structures is proposed.

In more detail, the paper is organized as follows. Section 2 is devoted to the organization of the MVDC power system into functional blocks. Power electronics equipment for the power sources, the load centers and the distribution network, are respectively addressed in Section 3, Section 4 and Section 5; the latter Section also outlines the system protection issues and technologies. Finally, Section 6 is devoted to the conclusions.

## 2. Functional MVDC blocks and related power electronics equipment

According to the functional MVDC block diagram drawn in [21], the MVDC power system of an AES is composed of three subsystems, each devoted to a specific operation, namely: production, distribution and utilization of the electric energy. Such subsystems are named respectively power sources, load centers and distribution network. Each subsystem includes one or more functional blocks. A simplified block diagram of the MVDC power system is shown in Fig. 1.

According to [21], the complete diagram includes also the control blocks, but they are omitted here. The number of functional blocks is not necessarily limited to the ones shown in Fig. 1.

Each functional block includes the equipment providing the main function (i.e. rotating machines for power generation, batteries, rotating machines for propulsion, etc.) and DC/AC, AC/DC or DC/DC power converters (as it is shown in Fig. 1), which connect the equipment to the MVDC bus. The MVDC bus can be itself considered a functional block that includes also power electronics equipment, namely solid-state and hybrid DC CBs.

Next, all functional blocks with the relevant power electronics equipment will be addressed in a dedicated Section.

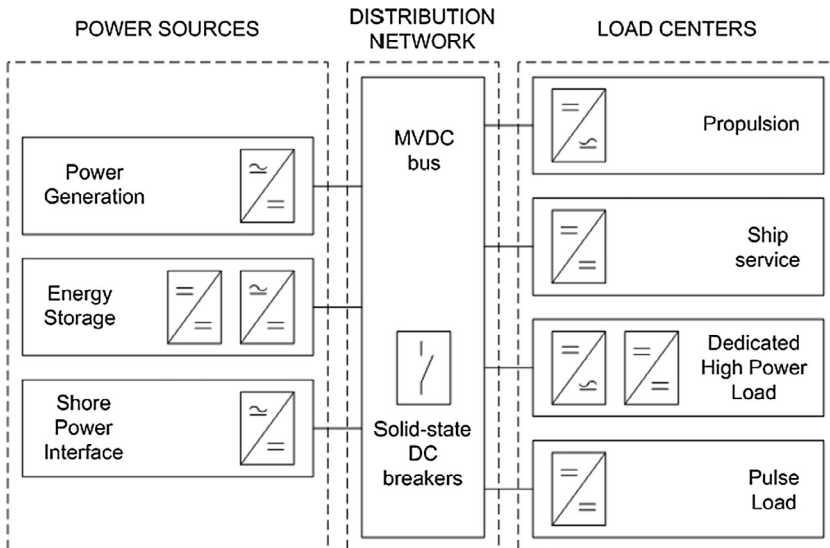

Fig. 1. Simplified functional MVDC block diagram highlighting the power electronics equipment included in each functional block (according to [21]).

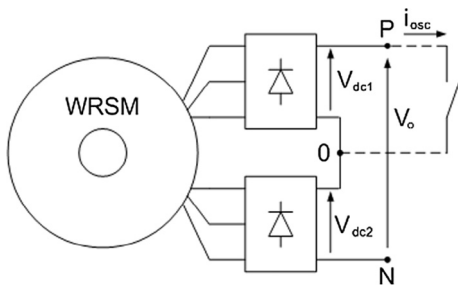

Fig. 2. Scheme of a DC generator system composed of a double three-phase wound rotor synchronous machine connected to the DC grid by two series-connected diode bridges.

### 3. Power electronics equipment for power sources

The “power sources” subsystem is composed of functional blocks performing three functions, namely power generation, energy storage and shore power interface. The power generation functional block and the shore power interface functional block are connected to the MVDC bus by an AC/DC converter system. The energy storage functional block is connected to the MVDC bus by an AC/DC or a DC/DC converter system, depending on the type of storage device.

#### 3.1. Power generation functional block

The main requirements for power generation systems of ships are: (1) output voltage control, (2) fault tolerance, (3) safety, (4) volume minimization.

MVDC power systems of AESs are isolated DC networks requiring a control system able to ensure voltage stability and power flow control [29]. Power generation systems are necessarily involved in the network control and should thus be able to control their output voltage according to the network demand.

Electric power systems of AES are safety critical systems requiring a high level of dependability. Among the dependability enforcement techniques there is fault tolerance [34], especially applied to the electric generators, which are crucial for electric power system survivability. Effective methods to pursue fault tolerance in shipboard generator design are reviewed in [37]. They particularly rely on the segmentation of stator active part into independent units connected to different rectifiers, according to a modular design that enables generator service continuity at reduced power in case of fault on a stator module.

An essential need in a ship is safety of systems, namely the avoidance of faults causing the damage of other systems, people or environment. For instance, capacitors are considered critical elements, since their fault may result in dangerous explosion and ignition events. Therefore, it is better to minimize employment of capacitors and, when it is necessary to use a capacitor, it has to be properly protected in order to avoid that its possible explosion may seriously damage the

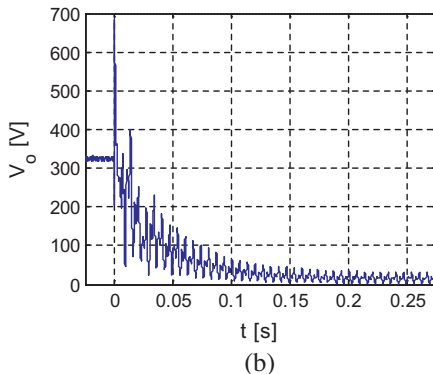
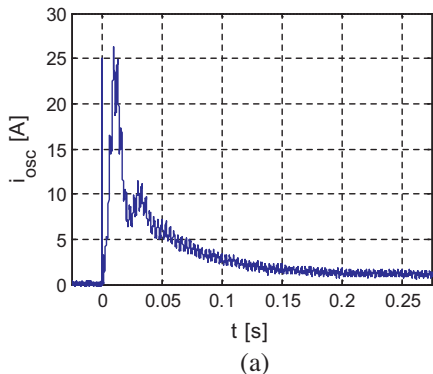

Fig. 3. Effects of an experimental short circuit test at the output terminals of one diode bridge of a DC power generator composed of two series-connected diode bridges fed by a double three-phase synchronous machine: (a) recorded current, (b) recorded voltage.

surrounding environment. As it will be explained later, an option of capacitor-free generation system is based on the employment of current-source SCR-based rectifiers.

Owing to the limited available space onboard, an important feature of all systems in a ship is their reduced volume. As a consequence, volume minimization is an important goal to be pursued when designing an electric power generation system for a ship. An effective way to minimize generation system volume is the employment of high-speed machines as prime movers and electric generators. In fact, as widely discussed in [38], raising the speed of the rotating equipment makes it possible to lower its rated torque and, hence, its volume.

The above listed demands and specifications have to be taken into account when choosing or designing power generation systems of MVDC shipboard power systems.

Power supply for shipboard power systems can be provided by an electric generator driven by a prime mover or a fuel cell. However, except for air-independent propulsion of submarines [39], the former solution is preferable at the moment, while several challenges will have to be addressed before fuel cells can be considered a valid alternative [40].

Excluding the employment of DC machines, owing to their well-known drawbacks related to commutator, brushes and sliding contacts, MVDC power systems require AC/DC converters to interface AC machines with the DC grid of the distribution network subsystem. Possible kinds of AC/DC converters suitable for this task are: (1) diode rectifiers, (2) thyristor phase-controlled rectifiers, (3) DC/DC converters cascaded to diode rectifiers, (4) PWM force-commutated rectifiers. In the following each of these solutions will be discussed.

The easiest solution is the employment of a diode rectifier if voltage regulation is possible by means of the excitation control of synchronous machines [41,42] or hybrid excitation synchronous machines [43,44]. This solution has many positive features such as simplicity, reliability, efficiency and low cost. However, short circuits at its output terminals cause large peak fault currents, which require an accurate knowledge of short circuit behavior of diode rectifiers in order to perform a suitable sizing of the system and its protections. For this purpose, in [45] models for simulation of DC generator systems with 6-pulse and 12-pulse rectifiers are implemented and validated by experimental tests.

In [45], the short circuit tests are carried out on an experimental setup composed of a reconfigurable 21 kVA, 50 Hz multiphase synchronous machine. In some of these tests the machine supplies two three-phase series-connected diode bridge modules, as shown by the circuit diagram in Fig. 2. In the double three-phase configuration the nominal voltage of the machine is 380 V; as a consequence, the nominal output DC voltage  $V_o$  is 1 kV. Some short circuit tests are carried out closing a switch connected between terminals P (positive) and 0 shown in Fig. 2. An example experimental recording of the voltage  $V_o$  and of the current  $i_{osc}$  as a short-circuit test result is shown in Fig. 3. The test is performed setting the no load output DC voltage  $V_o$  at about 30% of its nominal value. Results of the test show that the short circuit current is

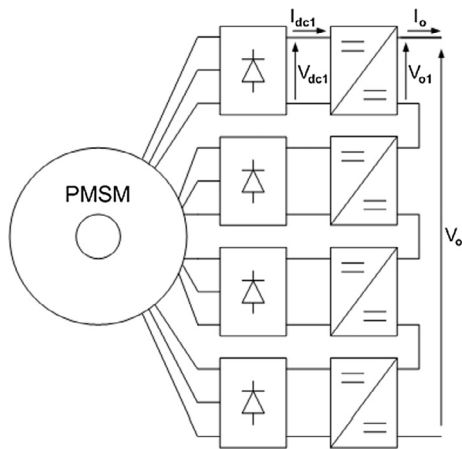

Fig. 4. Scheme of a DC power generator composed of a quadruple three-phase PMSM connected to the DC grid by four series-connected converters constituted by a DC/DC converter cascaded to a diode bridge.

affected by a high peak which would be much higher if the no load voltage were the nominal one. The voltage too exhibits a high peak occurring immediately after the short circuit and, after that, it oscillates decaying to almost zero. In fact, also the voltage  $V_{dc2}$  decreases at steady state due to the demagnetizing action of the short circuit current.

In [42] a full-scale prototype of a 3000-V, 2-MW on-board DC power generation system for the Italian Navy is presented. The system, sketched in Fig. 2, is composed of a 4-pole high speed Wound Rotor (WR) double three-phase Synchronous Machine (SM) coupled to a 22,500-rpm gas turbine by a gearbox, reducing the speed to 6300 rpm. The 1.2 kV AC machine is connected to the DC grid by two series-connected diode bridges, each one supplied by one of the two three-phase stator windings of the machine.

The prototype was designed in order to meet the main requirements for power generation systems of ships, outlined at the beginning of this subsection. Output voltage control is allowed by the excitation control of the WRSM. Fault tolerance is enhanced thanks to the presence of two three-phase stator windings and their relative diode rectifiers. Absence of filtering capacitors ensures a high level of safety. The system design pursued volume minimization through power density increase by the employment of a relatively high-speed generator and turbine.

In [42] waveforms can be found showing the simulated MVDC output voltage and current in steady state condition both in normal and faulty operation and the simulated and experimental MVDC output voltage and current subsequent to a load release and a load insertion.

Diode rectifiers can be employed also if the machine voltage regulation is not feasible. In [46] a system is proposed, built up as a reduced scale laboratory prototype, constituted by an induction generator

interfaced with DC loads by a diode rectifier. However, the induction generator requires an excitation system connected in parallel to its output terminals. In [46] the excitation system is composed of a capacitor bank and a reduced-size active power filter, able to both regulate the system output voltage by reactive power control and filter the harmonic currents, thus enhancing the machine efficiency.

An alternative to diode rectifiers is constituted by thyristor rectifiers. Besides the advantages which can be also found in diode rectifiers, i.e. high reliability, high efficiency, relatively low cost and long-time established technology, they add fault current control capability [47] and output voltage control. Also, current-source SCR-based converters, which employ DC link reactors, offer an interesting capacitor-free topology and their adoption should be considered in all cases where fast switching or high dynamics control performance do not make the choice unfeasible.

Taking advantage of the possibility to control the DC voltage, thyristor rectifiers could be theoretically used together with AC machines which do not allow for terminal voltage regulation, i.e. induction and permanent magnet generators (the latter being particularly attractive due to the almost null rotor losses and the possibility to get rid of external excitation systems). However, the DC voltage control through a thyristor rectifier would imply the absorption of a variable amount of reactive power, which cannot be supplied by a PMSM or an induction generator. Hence, it would be necessary to add some kind of reactive power generator, such as, for instance, a force-commutated DC/AC converter. The resulting configuration would be definitely redundant because the forced-commutated converter would be sufficient to control the terminal voltage [48], thus making it possible to use a simpler diode rectifier instead of the thyristor rectifier. In fact, to the best of authors' knowledge, no DC generator system employing a thyristor rectifier together with a PMSM or an induction generator can be found in the technical literature.

One more possible solution relies on the use of an AC/DC converter system composed of a DC/DC converter, such as a chopper, cascaded to a diode rectifier [41,38]. This solution allows for fault current limiting [49,50] at the DC bus terminals and better voltage control with respect to solutions employing diode rectifiers [41]. Moreover, it can be used together with a PMSM [38] to build up a reliable, efficient, small size DC generator system with fast voltage control.

As an example, [38] presents a second more technologically-advanced (compared to the one in [42]) full-scale prototype of a 3000-V, 2-MW on-board DC power generation system for the Italian Navy. Its block scheme is sketched in Fig. 4. Also in this case a 4-pole high speed machine is driven by a 22,500-rpm gas turbine. However, the machine is a quadruple three-phase 620 V PMSM and it is directly coupled to the gas turbine.

Each three-phase stator winding of the PMSM supplies the power electronics unit shown in Fig. 5, composed of a bidirectional chopper

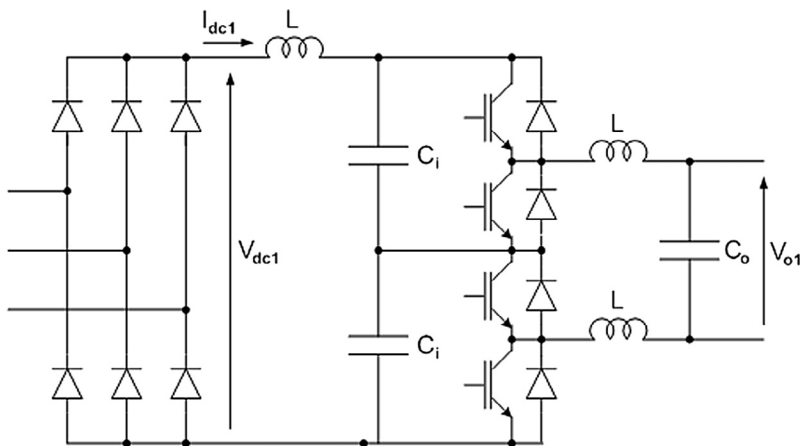

Fig. 5. Circuit scheme of a power electronics unit ( $L = 200 \mu\text{H}$ ,  $C_i = 1600 \mu\text{F}$ ,  $C_o = 1000 \mu\text{F}$ ) for the PMSM solution.

cascaded to a diode bridge.

The power switches of the chopper are 1200-V 600-A IGBTs. The switching frequency is 6 kHz. The nominal output voltage and current are respectively 750 V and 500 A.

In case of heavy abrupt load reduction, the dc-link voltage is allowed to increase up to the maximum value of 1500 V, thanks to the circuit structure of the chopper, where the input voltage is sustained by two series connected IGBTs. Finally, an input LC filter and an output LC filter complete the chopper scheme.

Also this prototype (like the one in [42]) was designed in order to meet the main requirements for power generation systems of ships, outlined at the beginning of this subsection. In this case, a higher-end technology is adopted compared to [42] to further optimize the design in view of its MVDC shipboard application. Very fast output voltage control is allowed by the chopper of the power electronic unit shown in Fig. 5. A very high level of fault tolerance is ensured by the presence of four three-phase stator windings and their relative power electronic units. Employment of input and output filtering capacitors is necessary respectively for the good operation and good output voltage quality of the bidirectional choppers. Nevertheless, a good level of safety is ensured by the addition of an appropriate explosion-proof enclosure for the capacitors. The system design pursued volume minimization increasing power density by the employment of a ultra-high-speed machine [38] and the consequent elimination of the gearbox.

A number of tests have been made at different machine speeds and different load conditions on the generation system under discussion.

The first one was a no load test at three different machine speeds. Results of the test are reported in Fig. 6a, where it can be seen that the output voltage is regulated according to the generator speed up to a certain frequency and then it is kept constant. In the second test the system was loaded with an  $8\ \Omega$  resistor, at constant machine speed (18,000 rpm) and different DC output voltages. Results of the test are reported in Fig. 6b.

Thanks to the output LC filter and the high switching frequency, the output voltage ( $V_o$ ) and the output current ( $I_o$ ) of the DC power generator are perfectly smoothed. On the contrary, the output voltage ( $V_{dc1}$ ) and output current ( $I_{dc1}$ ) (Fig. 4) of the diode rectifier are affected by a certain ripple, as shown in Fig. 7, where waveforms of the dc-link quantities recorded during the on-load test are reported.

More advanced AC/DC converters are the force-commutated rectifiers [51,52], which offer fast dynamic DC output voltage control with unity power factor operation. Therefore, they absorb no reactive power and, contrary to diode and thyristor rectifiers, their input current is sinusoidal, thus increasing machine efficiency and reducing torque pulsations. On the other side, they require voltage synchronization, converter efficiency is lowered by the commutation losses, technology is less established and, above all, they are expensive and do not allow fault current limitation.

In [51], in addition to systems with diode rectifiers, synchronous and induction generators are proposed operating at variable speed and interfaced to the grid by 2-level and 3-level voltage source converters

(VSC). In the paper, experimental results obtained by few-kW laboratory prototypes of the proposed systems are shown.

In [52] different kinds of converters, employed to interface a 5-MVA 400-Hz high speed generator to the grid, are compared. The compared converters are 2-level converters, diode clamp and flying capacitor 3-level converters and four kinds of auxiliary resonant commutated pole soft-switching converters (three with 3-level structure and one with 4-level structure). However, the comparison is made on the basis of simulation results and no experimental prototypes are built.

A DC power generation system can also be implemented taking advantage of a proven technology, namely the concentrated stator winding PMSM prototype shown in Fig. 8 [53,54]. The prototype is actually built to prove the feasibility of a high power direct drive wind generator with relatively low manufacturing cost. The machine has a modular structure consisting of stator windings subdivided into identical magnetically decoupled three-phase sections being able to operate independently.

The prototype shown in Fig. 8 is composed of four separated three-phase sections, resulting from the series connection of several individual stator modules, shown in Fig. 8b. The four machine sections are connected to two PWM force-commutated rectifiers, as shown in the scheme of Fig. 9, where a machine section and the one displaced by 180 mechanical degrees are connected to the same AC/DC converter. The two AC/DC converters are series connected in order to supply a two or three-wire MVDC grid.

If a fault occurs in an AC/DC converter it can be bypassed by closing the switch connected between its output DC terminals and opening the switches connecting its input AC terminals to the two machine sections supplying it. In this way the generator can remain in operation with degraded performance.

On the other hand, also if a machine section suffers a fault it can be disconnected by the same procedure, disconnecting both the machine sections connected to the same AC/DC converter in order to avoid possible vibration issues due to imbalances in the stator loading.

The AC/DC converters could be DC/DC converters cascaded to diode rectifiers, like the structure of the power electronics unit depicted in Fig. 5. However, decoupled three-phase sections, although being an advantage from a fault tolerance point of view, do not allow for air-gap harmonic field cancellation like in the split-phase machine of Fig. 4. Furthermore, concentrated-winding stator designs are known to produce highly distorted air-gap fields [53,54]. Also for these reasons, it is more suitable to employ AC/DC converters characterized by nearly sinusoidal current waveforms on the AC side, namely three-phase PWM force-commutated rectifiers, in order to reduce rotor additional losses. Among the mentioned kinds of converters, the most common are the PWM-controlled IGBT-bridges. As an alternative to this well-known structure, others more efficient and less expensive three-phase rectifier topologies with sinusoidal input current and controlled output voltage can be employed [55,56]. An example is the so called Vienna rectifier, which is a unidirectional unity-power-factor rectifier halving the number of active switches and their voltage sizing with respect to the

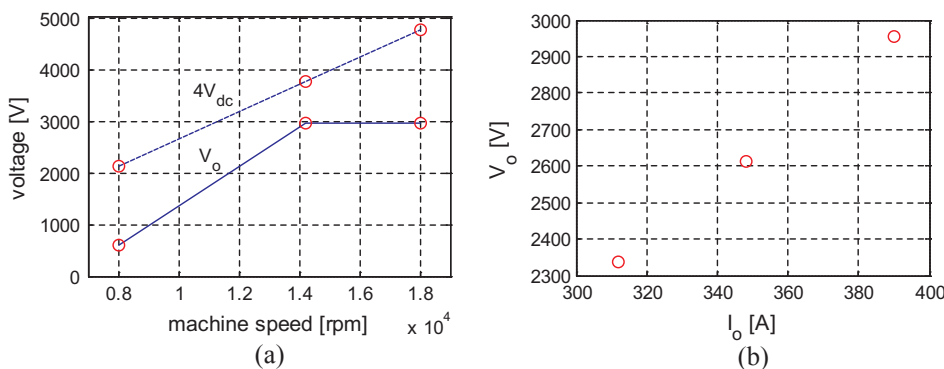

Fig. 6. DC power generator steady state tests: (a) measured output regulated DC voltage ( $V_o$ ) and unregulated dc-link voltage ( $4V_{dc1}$ ) at different machine speeds, (b) measured output voltage ( $V_o$ ) and output current ( $I_o$ ) at constant machine speed (18,000 rpm) with an  $8\ \Omega$  resistor load.

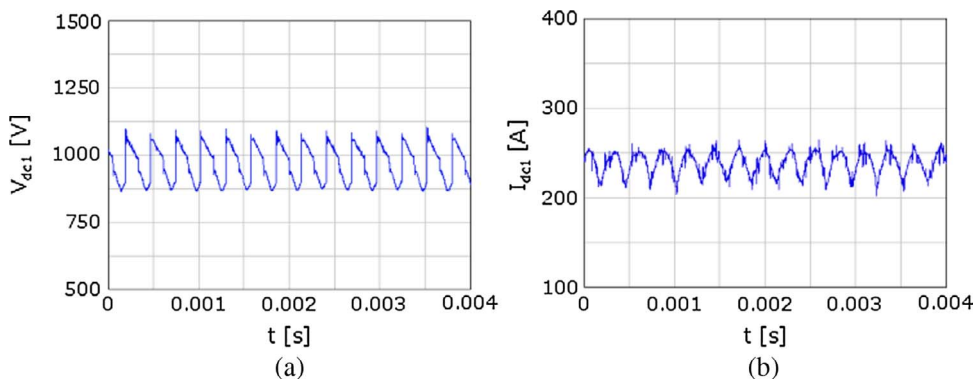

Fig. 7. Measured output quantities of the diode rectifier: (a) voltage ( $V_{dc1}$ ), (b) current ( $I_{dc1}$ ).

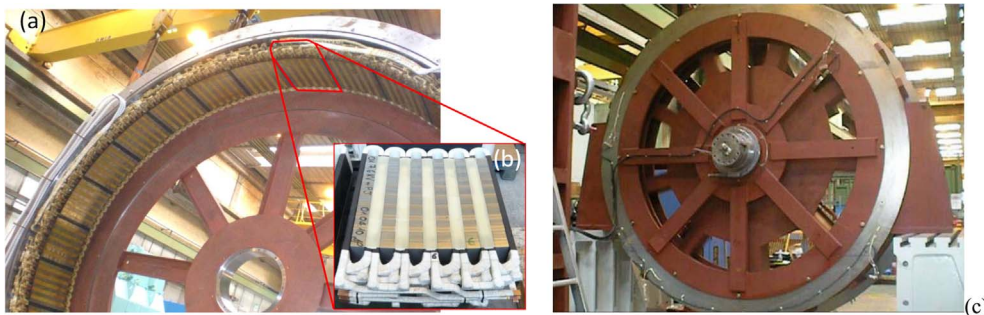

Fig. 8. Pictures of the permanent-magnet machine prototype for off-shore direct-drive wind generation. (a) Stator during manufacturing; (b) single stator module; (c) overall built generator.

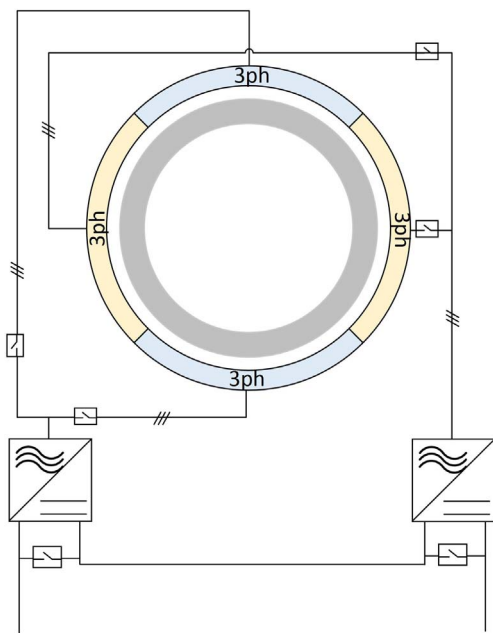

Fig. 9. Scheme of a DC generator system composed of a concentrated stator winding permanent-magnet synchronous machine connected to the MVDC grid by two series connected PWM-controlled IGBT-bridges.

three phase bridge [57].

In order to further enhance the fault tolerance of the system, the same concept of the prototype of Fig. 8 can be applied to the design of a machine endowed with more decoupled three-phase sections [37]. In this case each machine section would supply a low voltage AC/DC converter and all the AC/DC converters would be cascaded and connected to the MVDC bus.

### 3.2. Energy storage functional block

Employment of energy storage systems [58] in microgrids [59] and shipboard power systems is nowadays a viable solution [60] which brings some challenges, mainly related to the grid control strategy, together with several benefits [22]; for instance they allow fuel saving [61], help voltage regulation and stability enhancement, perform peak shaving required to manage pulse loads [62] and fast load changes, and constitute a spinning reserve [21].

Main energy storage systems suitable for shipboard power systems [60,63] are batteries [64], ultracapacitors (usually paralleled to batteries to constitute a hybrid energy storage system [63,65–67]) and flywheels [68,69].

As stated before, energy storage systems require power converters to be interfaced to the electric grid [70,71].

Batteries and ultracapacitors are DC storage systems requiring bi-directional DC/DC converters to be connected to the MVDC power system. These converters have to handle high power levels, even if not in a continuative way. A converter for this application is addressed in [72], even if it is conceived for application to a low voltage AC (LVAC) grid. A novel converter topology connecting energy storage batteries and ultracapacitors to the shipboard MVDC system and performing active filtering functions is proposed in [63]. The proposed converter is an isolated bidirectional DC/DC converter based on the modular multilevel converter. Both low-voltage-side and high-voltage-side modules are H-bridges, each one connected to a battery in the low-voltage-side and to a ultracapacitor in the high-voltage-side.

Flywheel storage systems, where the mechanical energy stored in the flywheel is converted to electrical by an AC electrical machine, are AC storage systems which require an AC/DC converter to be connected to the MVDC grid. Since the storage system has to supply energy to the grid, but also to be recharged, AC/DC bidirectional converters have to be employed. Medium voltage converters with multilevel structure, such as the neutral-point-clamped (NPC) VSC [73], the cascaded multilevel VSC [74] and the other multilevel structures described in [75–77], are the most suitable to be directly connected to a MVDC grid.

In recent years, the number of grid-scale battery energy storage

systems is seeing a fast growth and different battery technologies are being developed. In particular, a number of onshore battery storage systems have been installed in Italy [78–80]. Different kinds of batteries, such as lithium-ion, sodium-sulfur, sodium-nickel chloride, vanadium redox flow batteries, from different producers have been successfully used. Lithium-ion, sodium-sulfur, sodium-nickel chloride batteries could be suitable to be employed in MVDC shipboard power systems since they have high energy density, high life cycle, high efficiency and not too high cost [64,81]. Vanadium redox flow batteries have the higher life cycle and lower cost, but also the lower energy density [81], which at the moment makes them not suitable for shipboard applications.

An example of MV battery-based energy storage system is shown in Fig. 10. Fig. 11 shows an oscilloscope screenshot saved during laboratory system testing. It displays the battery current, the output AC current and the DC bus voltage obtained during a transition from maximum absorbed power to maximum delivered power. The transition time is 90 ms, being 100 ms the limit established as acceptance criterion.

Even if the system of Fig. 10 is conceived for a MVAC power system it can be adapted to a MVDC power system by substituting the DC/AC converter and the LV/MV transformer in the scheme of Fig. 10b with a suitable DC/DC converter, such as one of those with bidirectional structure which will be described in Section 4.

### 3.3. Shore power interface functional block

Energy supply of docked ship by a shore connection is mainly conceived to meet the requirements of energy saving and emission reduction [82–84]. Shore connection of ships raises a number of issues and challenges, such as port infrastructure upgrade [85], transient overvoltage protection [86], prevention of dangerous touch potential in case of line-to-ground fault [87,88], identification of appropriate sizing methods [89].

Of course, an interface power converter is needed and it can be

exploited together with the energy storage of the onboard power system to provide ancillary services to the onshore power system [90]. The AC/DC converter for the shore power interface of a MVDC ship power system could be installed onboard or onshore. However, since ships with a DC power system are not yet widespread, it is reasonable to assume that the interface converter is installed onboard.

Solutions of converter systems for shore power interface of MVAC ship power systems are presented in [91]. Even if the technical solutions proposed in [91] are conceived for ships with MVAC power system, some of them can be partially utilized for the design of converter systems for shore power interface of ships with MVDC power system.

The shore power interface could employ a line commutated thyristor rectifier, which has the merit of established technology, high reliability, high efficiency and relatively low cost. As a counterpart it impairs power quality owing to reactive power absorption and, above all, harmonic current injection. Countermeasures are capacitor banks, harmonic filters, 12 pulse and 24 pulse converter configurations [92]. However, thyristor converters cannot provide ancillary services to the grid.

A class of converters able to enhance power quality and to provide ancillary services to the grid is the same which has been identified as the most suitable to connect AC storage systems to the MVDC grid (Section 3.2). Given the present state of the art, according to the authors the most suitable AC/DC power converter systems for shore connection of ships with MVDC power system are based on the three-level NPC topology [73,83].

## 4. Power electronics equipment for load centers

The “load centers” subsystem includes four functional blocks, namely propulsion, ship service, dedicated high power load and pulse load. Propulsion is connected to the MVDC bus by DC/AC converter systems. Ship service is connected to the MVDC bus by a DC/DC converter. Dedicated high power load is connected to the MVDC bus by

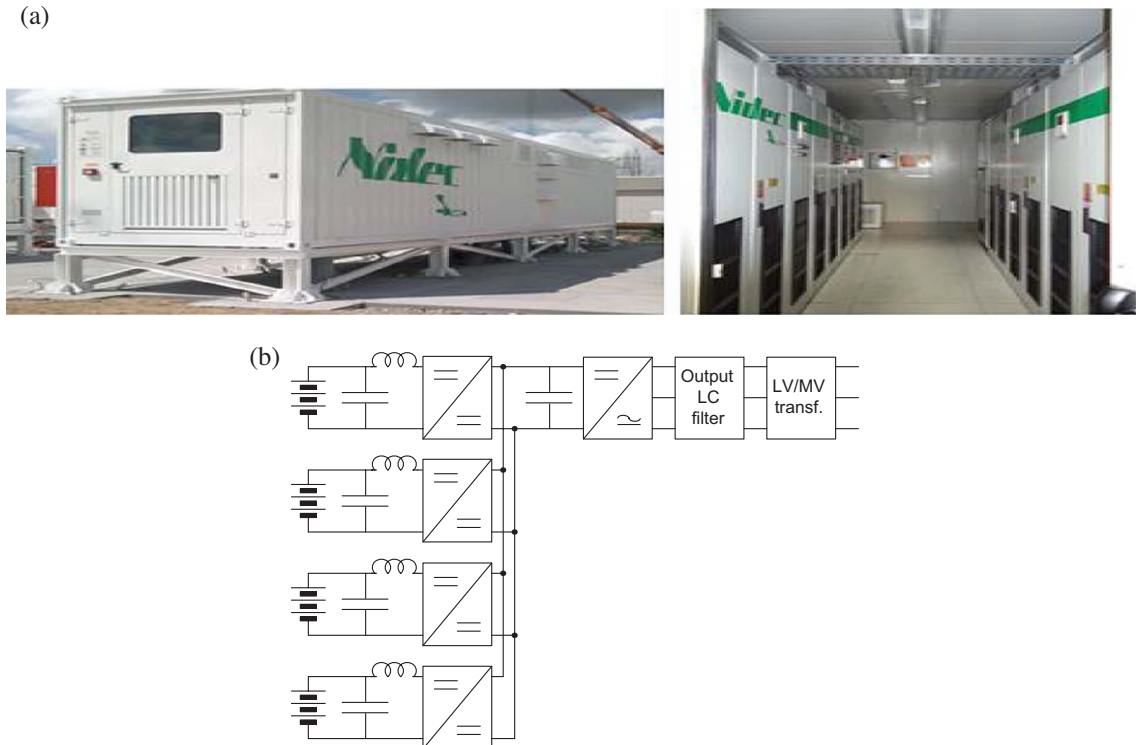

Fig. 10. 2.4 MW energy storage system based on electrochemical accumulators: (a) pictures showing the outside and inside views of a container keeping part of the system equipment, (b) system block scheme.

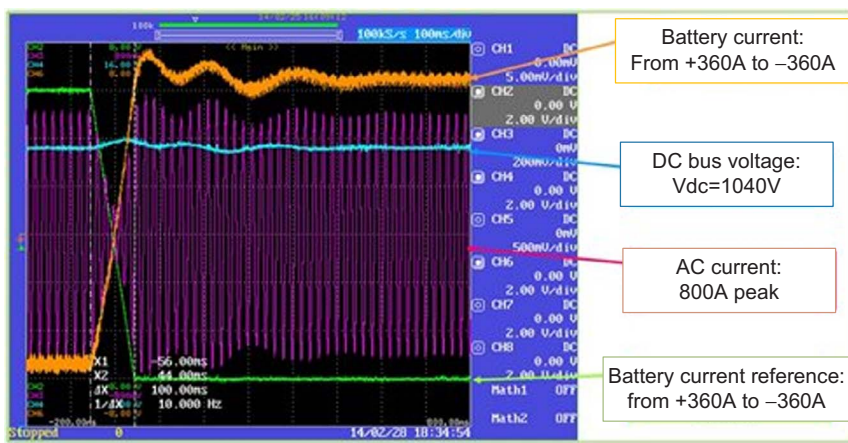

Fig. 11. Screenshot showing the battery current (reference and actual), the DC bus voltage and the AC current measured during a transition from maximum absorbed power to maximum delivered power.

DC/AC or DC/DC converter systems, depending on the type of supply required by a specific load. Pulse load is connected to the MVDC bus by DC/DC converter systems.

#### 4.1. Propulsion functional block

The propulsion functional block is composed of high power electric drives. Overviews of power converters for ship electric propulsion drives are provided in [93–96]. Among the high power converters reviewed in [93–95] the SCR-based ones (i.e. LCIs and cycloconverters) offer the advantage of a well-known and established technology, commonly employed for instance for cruise ship propulsion [97]. However, the requirement of an AC supply makes them not suitable for ships with MVDC power system. A DC power supply requires the employment of DC/AC PWM VSCs. An example of propulsion drives employing PWM VSCs is given by the case study in [98], where the propellers of a megayacht are driven by two 1.1 MW VSC-fed PMSMs. The propulsion converters are common bridge VSCs connected to a 690 V LVAC bus by six-pulse diode rectifiers. Removing the diode rectifiers, they could be directly supplied by a LVDC power system, but they are not suitable for medium voltage supply.

Electric drives employing VSCs with multilevel structure [96], such as the three-level NPC VSC [73], the Modular Multilevel Converter (MMC) structure [99], and many of the structures described in [75–77,100–103], are the most suitable to be directly connected to a MVDC grid. Usually, such high power drives are intended to be supplied by a MVAC grid; however, many of them can be easily adapted to a MVDC supply, mainly removing the AC/DC converter that interfaces the electric drive to the AC network.

Multilevel converter-based ship propulsion drives which can be easily adapted to be connected to a MVDC grid are proposed in [104–108]. In particular, the propulsion drive proposed in [104] and tested by computer simulations is based on a four-level flying capacitor multilevel converter feeding a three-phase induction motor. Another induction machine drive is proposed and tested by simulations in [105], where the motor is supplied by a nine-level MMC. The multilevel converter-based induction motor drives addressed in [106–108] are proposed to shipbuilders by two of the main manufactures of high power electric drives. In particular, the ones in [106,107] employ the technologically well-established NPC structure, while the one in [108] employs a novel advanced three-level topology, named Neutral Point Piloted (NPP) [109].

Just like electric generators, fault tolerance is an essential feature of electric propulsion drives. One of the main solutions to pursue fault tolerance is redundancy. In [110,111] available solutions of VSC-based drive systems with redundant and multiphase structure are reviewed.

In [112] a propulsion drive is proposed and experimentally tested where the motor is supplied by two parallel-connected three-phase

bridge VSC units. The VSC units are connected to the positive dc-link bus by power electronic switches controlled in a complementary way in order to direct the current in one VSC unit and allow zero-current switching (ZCS) of the other VSC unit. Thanks to the ZCS switching, loss reduction and high switching frequency is achieved. Moreover, in case of fault of a VSC unit, the healthy unit can be operated as a normal PWM hard-switching VSC, thus ensuring fault tolerance.

In [113] a fault-tolerant ship propulsion drive is proposed and tested by computer simulations. The system is based on a double three-phase induction motor supplied by a nine-switch VSC (in place of two six-switch bridge VSCs) and is able to operate also in case of fault of a switch or of a motor phase winding.

Fault-tolerant multi-phase propulsion drives also require a suitable control strategy in case of fault. In [114], fuzzy logic current controllers are employed for rotor-flux oriented control of a nine-phase induction motor supplied by a nine-leg VSC. Different faulty conditions are experimentally tested and the results show that the proposed control method, compared with conventional control methods employing PI current controllers, is able to improve the performance of the system in faulty conditions.

A fault-tolerant MMC DC/AC VSC for shipboard MVDC applications is proposed, simulated and experimentally tested in [99]. Also in that case the fault tolerance ability is based on a control strategy, named hierarchical redundancy strategy.

Examples of fault-tolerant propulsion drives are installed on board the Italian FREMM class of frigates [115]. They are part of a hybrid propulsion system composed of a 32-MW gas turbine and two 2.15-MW electric drives, which can operate also as shaft generators. Electric motors are PMSMs endowed with a quadruple-three-phase stator winding. Each three-phase winding is supplied by a DC/AC PWM bridge converter, which is in turn supplied by an AC/DC PWM bridge converter, named Active Front-End (AFE). The four AFEs of each drive are connected to the 6.6 kV AC naval grid through a step-down transformer.

Another example of redundant multi-phase propulsion drive is the one installed on board the type 212A and 214 submarines [116]. The electric motor is a twelve-phase PMSM, whose stator phases are individually supplied by a PWM VSC module. The phase windings are divided into two parts. The VSC modules are constituted by two single-phase IGBT bridges, each one supplying a part of a stator phase winding. Each VSC module, in addition to an input filter, has a series transistor-switch for reverse current blocking in case of short circuit. The VSC modules are part of the motor and contain also the phase current control system, the electronic equipment for communication with the central propulsion control system and an integrated DC/DC power supply. Six of the twelve VSC modules are connected to the LVDC power system by a feeder and the other six by another independent feeder.



#### 4.2. Ship service functional block

The ship service functional block includes zonal Low Voltage DC (LVDC) and Low Voltage AC (LVAC) distribution. DC/DC converters, performing the function of SSTs, reduce the amplitude of the IPS MVDC voltage to LVDC in order to supply both LVDC buses and, through LV DC/AC converters, LVAC buses.

The availability of SSTs constituted by high power DC/DC converters with acceptable price and efficiency is one of the key points discriminating if it is convenient or not to use a MVDC distribution.

DC/DC converters are widespread for low power levels and there are many variants of them. However, most of them are not suitable to handle power levels in the order of MWs. The main limitations depend on the nature of high power switches, the operating frequency and the efficiency [117]. Nevertheless, in recent years a lot of research works about high power DC/DC converters can be found in the scientific literature owing to the increased interest for MVDC and even more HVDC networks. The feasibility of these converters is the result of the greater and greater development of power electronics over the last few decades. A review of DC/DC converters for HVDC transmission networks can be found in [118].

The following of the subsection includes a brief overview of many of the most important structures of high power step-down DC/DC converters proposed in the recent scientific literature. The overview presents, with some digressions, the most diffused structures found in the literature and leads to the proposal by the authors of a new topology fitting the needs of three-wire bipolar MVDC power systems. The presented structures can be classified as shown by the block diagram in Fig. 12.

According to the classification shown in Fig. 12, the structure of a high-power DC/DC converter can be monolithic or modular. Among the monolithic topologies, two main kinds of structure can be identified, namely the single-stage structure and the double-stage structure, that is a structure with a DC/AC input stage and an AC/DC output stage.

Apart from a few significant examples, such as the three-level buck topology proposed and experimentally tested in [119] and the five-level DC/DC converter presented and tested in [120] through a 10 kW prototype ( $V_{in} = 1.3$  kV,  $V_{out} = 800$  V,  $f_s = 20$  kHz), most of the step-down single-stage DC/DC converters proposed for high-power applications have a modular multilevel structure. They are named Modular Multilevel DC/DC converters (MMDC) and are in some way inspired to the MMC [121,122]. In [123] the MMDC is compared to other two

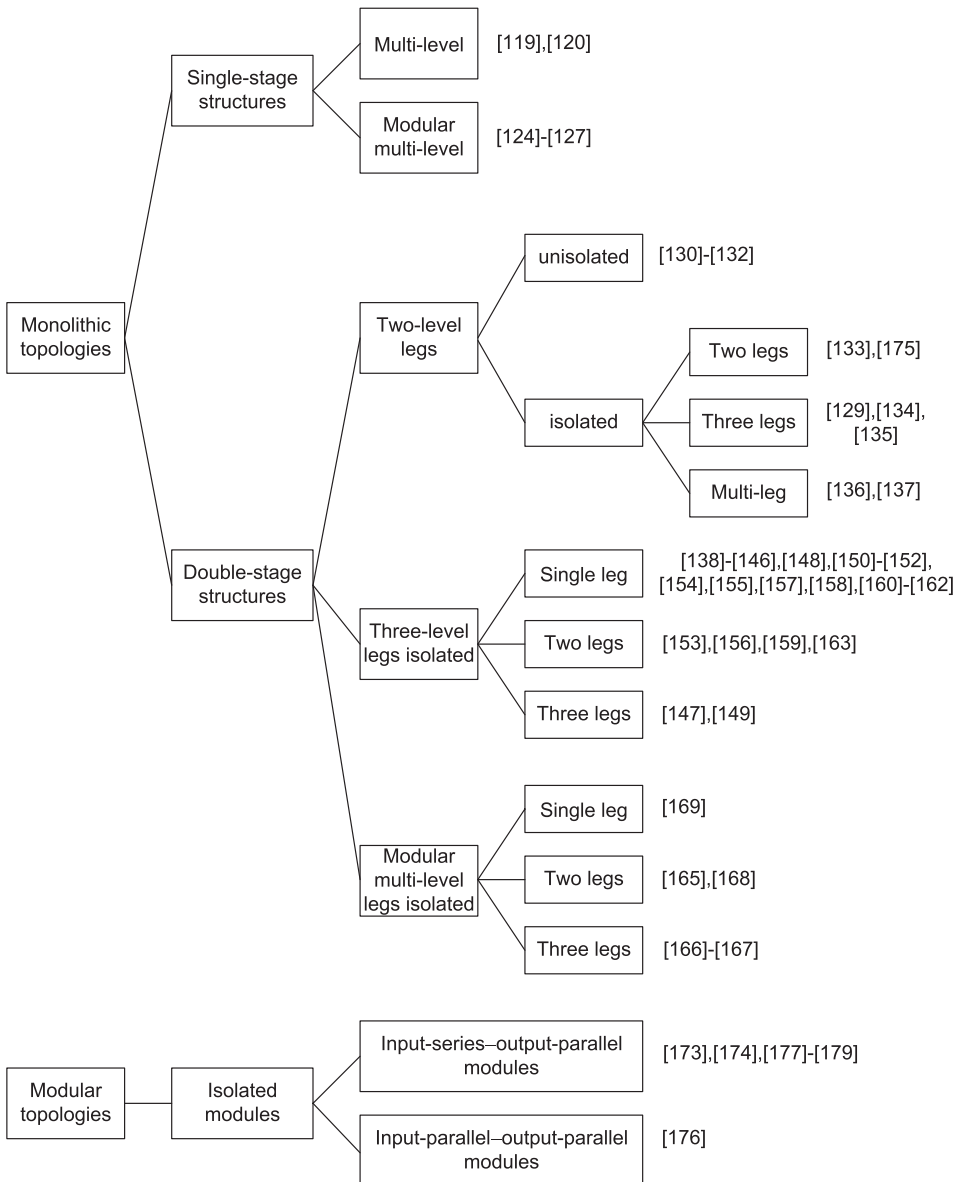

Fig. 12. Classification of high-power DC/DC converters for step-down SSTs.

cascaded multilevel topologies (the cascaded buck and cascaded boost); however the paper is focused on the design, control and experimental test of a MMDC for traction applications with regenerative braking. Of greater interest for MVDC applications are [124,125], where MMDCs for medium and high voltage applications are analyzed. In [124] two MMDC topologies are proposed, one to step-up and the other to step-down the voltage. Three MMDC topologies (a step-down, a step-up and a step-up/down) are also compared in [125].

MMDC requires a large number of high isolation transformers or complicated control algorithms to balance the DC capacitor voltages. In order to cope with this problem, in [126] a resonant MMDC topology with inherent voltage balancing is proposed.

A variation of the MMDC topologies, called MMDC triangular topology, is proposed and experimentally tested with a reduced scale prototype in [127]. The merit of this structure is to improve the power sharing among the converter modules and reduce input current and output voltage ripple. Moreover, the converter can provide multiple input and multiple output.

In [128] the MMDC is compared to the three-phase dual-active bridge converter [129], which is a double stage structure. The converters are designed for two applications where they connect a MVDC grid with a HVDC grid and two applications where they connect two HVDC grids. The comparison is made in terms of efficiency and sizing (amount of semiconductors and magnetic components). In all the analyzed applications the MMDC requires a much higher amount of semiconductor devices with respect to the dual active bridge converter, therefore it is more expensive. Moreover, if the difference between input and output voltages is high (as it occurs in three out of the four analyzed scenarios), efficiency of the MMDC is considerably lower than the dual active bridge.

The just mentioned comparison results suggest that dual-active bridge converters are more advantageous than MMDCs for application as step-down SSTs in MVDC power systems. In fact, for very high power applications several examples of double-stage DC/DC converters, with or without galvanic isolation, can be found. In many of the proposed structures the input and output stages are connected by an AC resonant circuit, aimed at supporting soft switching operation and therefore increasing SST efficiency.

Some double-stage DC/DC converters have a recently designed structure with no galvanic isolation. One of the most significant examples is the bidirectional resonant DC/DC thyristor converter presented in [130] for application as SST and experimentally tested in [131] by a low voltage 30 kW prototype. Another one is the DC/DC resonant converter presented in [132], having the input and output stages both with IGBT H-bridge structure and separated by a LCL circuit.

Nevertheless, in the majority of the double-stage structures found in the literature a medium or high frequency transformer is included to galvanically isolate the output stage from the input one [14].

A soft-switching DC/DC converter using a three-phase transformer connecting two three-phase transistor bridges, named three-phase dual active bridge converter, is described and experimentally tested in [129]. Other prototypes are the more recent converter proposed in [133], which has a single phase structure, and the converters in

[134,135], which have a three-phase structure like the one in [129]. However, a multi-phase technology would offer the advantage of splitting the energy flow among many converter arms and would lead to implement fault tolerance solutions, provided that it is endowed with a control system allowing for converter degraded operation in case of a faulty leg.

In [136,137] the multiphase resonant DC/DC converter shown in Fig. 13 is studied in detail and its performance is tested on a 5-kW prototype (input voltage  $V_i = 400$  V, switching frequency  $f_s = 100$  kHz). The input stage is composed of two-level legs equipped with fully controlled devices, while the output stage is composed of diode legs. The phase resonant circuit is constituted by the capacitor  $C_r$  and the leakage inductance of the high frequency transformer connecting the AC sides of the input and output stages.

In the mentioned converters both the input and the output stages have a two-level structure. However, a multilevel structure would be more suitable for the converter input stage, which is directly connected to the MVDC bus.

Actually, for high power applications a very high number of isolated DC/DC converters with a three-level structure in the input stage can be found in the literature [138–163], all with NPC topology, except for the converter in [163], which is a hybrid solution inspired to the flying capacitor multilevel structure and the cascade multilevel structure. The first converter of this type is introduced in [138]. It has the NPC input stage separated from a diode bridge output stage by a simple two-winding transformer. However, the basic structure to which most of the other structures are inspired is the one introduced in [139] and shown in Fig. 14.

Many of the converters have the NPC input stage endowed with a flying capacitor [140–143,148,150–152,154–158,160,162]. Most of the input stages are composed of a single leg, but some of them have two [153,156,159,163] or three [147,149] legs. In most cases the transformer has two windings with center-tapped secondary [139–144,147–150,154,156,157,159–161,163], like in Fig. 14. However (like in [138]), it sometimes has a simple two-winding structure supplying a diode-bridge [145,146,153], a three-phase structure [147,149,158,162], or a special multi-winding configuration [151,152,155].

All the converters in [138–163] are tested by laboratory prototypes with low voltage input (ranging from 400 V to 800 V), high switching frequency (ranging from 20 kHz to 110 kHz, only one of 5 kHz [153]), low power (ranging from 500 W to 7 kW, only one of 16 kW [159] and one of 20 kW [161]), but no full-scale high power realization of any of them is reported.

Other kinds of double stage isolated multilevel DC/DC converters for medium and high voltage applications are based on the already mentioned MMC [164], also inspiring the previously discussed so called MMDCs, which are single stage DC/DC converters. In [165–169] modular multilevel DC/DC converters are proposed, where a medium frequency transformer isolates the input stage (a DC/AC MMC) from the output stage (an AC/DC MMC). In [165,168,169] the MMCs and the transformer are single-phase (the MMC in [169] has a single leg, while in [165,168] it has two legs), while in [166,167] they are three-phase. The converter in [168] has DC fault current control capability. It is

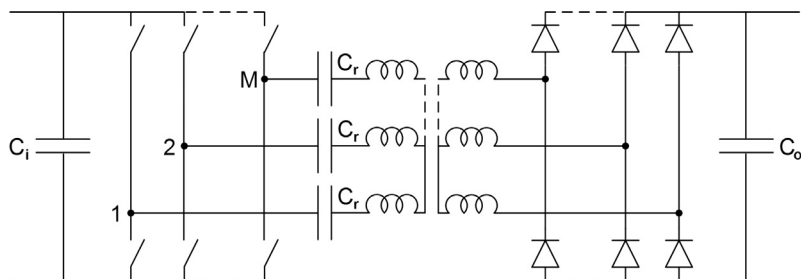

Fig. 13. Circuit diagram of multi-phase series resonant DC/DC converter.

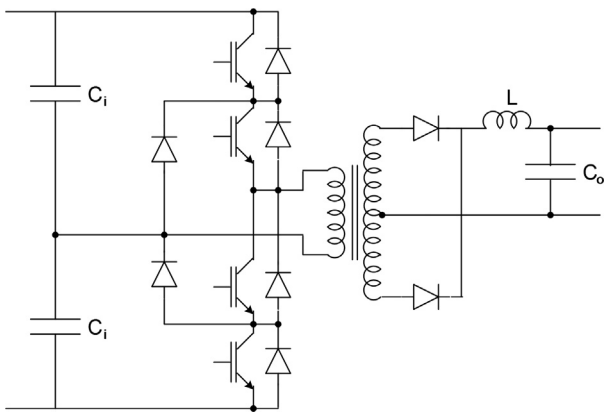

Fig. 14. Circuit diagram of a three-level soft-switching DC/DC converter.

applied for interfacing a battery energy storage system with the MVDC grid, however it is suitable also to be employed as SST. The converter in [169] is specifically conceived for employment in shipboard MVDC power systems. In [170] the optimal design aiming at minimizing the total power loss, size and weight of a three-phase MMC suitable for DC/DC converters is addressed. In [171] a soft switching operation scheme for a MMC-based isolated DC/DC converter with a high frequency AC-link is proposed. High frequency allows a size reduction but leads to increased switching losses. The proposed soft switching operation aims at reducing the switching losses and therefore increasing the system efficiency. Experimental results obtained by reduced-scale laboratory prototypes are provided in [165,167–169].

Another kind of converter very suitable for medium voltage applications is the modular converter, which in [172] is said to be the next generation MV power conversion system. Actually, the same classification shown in Fig. 12 for monolithic converters could be proposed also for each module of modular converters. However, the most diffused modular structures found in the recent literature are based on the bidirectional isolated DC/DC module described in [172]. Among these structures there are the modular input-series-output-parallel converters addressed in [173,174]. In [173] a traction converter is developed, designed and experimentally tested through a prototype which consists of only one 70-kW module ( $V_i = 666$  V,  $V_o = 750$  V,  $f_s = 13$  kHz). A similar converter as the base structure for an SST is described and experimentally tested through a 1 kW prototype in [174].

All the high power DC/DC converters found in the above mentioned literature are built as reduced-scale laboratory prototypes. On the other hand, two examples of full-scale laboratory prototypes for shipboard applications can be found in [175,176]. In [175] two 1-MW prototypes of resonant dual active bridge bidirectional DC/DC converters are built and experimentally tested. The converters are intended to perform the function of HV/LV SSTs in MVDC shipboard power systems. In [176] another MW-level prototype is built in order to test the performance of a proposed DC/DC converter for MVDC shipboard applications. The converter is composed of three paralleled isolated modules, each one having the full-bridge NPC structure of the converter addressed in [153].

The technology for building converters to be employed as SSTs in MVDC distribution systems could be borrowed from modern traction converters. Modular traction converters are the only ones already proposed by manufacturing companies [177–179] to the best of authors' knowledge. Modern traction converters, in fact, have a modular structure like the one described in [173,174]. Each module contains a medium frequency transformer, which enables weight and size abatement. Actually, it is declared that a 50% weight reduction can be achieved in the line-side stage (including transformer and filter) with respect to converters employing a line-frequency transformer [180].

In [178,179] the converter system named Power Electronic Traction

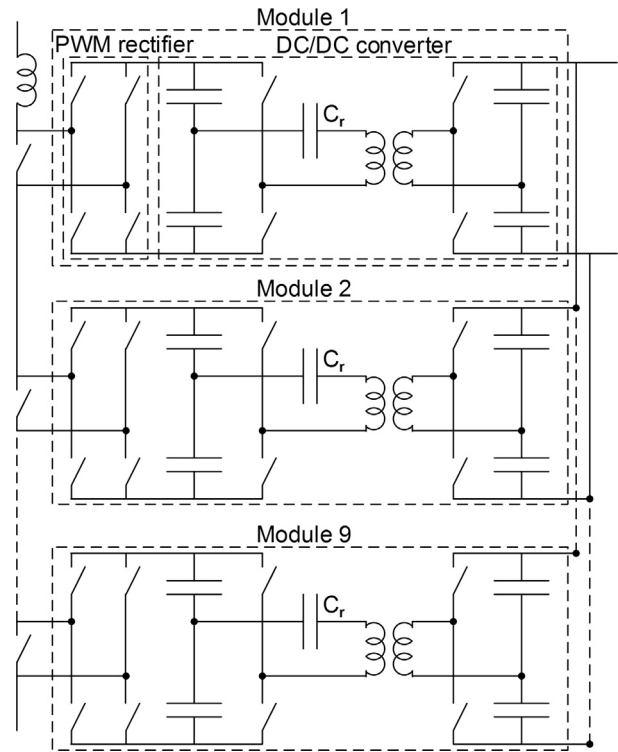

Fig. 15. Circuit diagram of the power electronic traction transformer.

Transformer (PETT), drawn in Fig. 15, is presented.

A pilot PETT has been installed in a shunting locomotive currently operating in a Swiss station. The installed PETT has nine 1.2-MW modules, of which only eight are essential for the converter operation (the ninth is for redundancy). Input voltage is 15 kV at 16.7 Hz. DC-link voltage of each module is 3.6 kV and the DC output voltage is 1.5 kV. The overall weight, including the cooling system, is 4500 kg and the power density of transformer and rectifier is in the range of 0.2–0.35 kVA/kg. However, the system was not optimized in this first pilot installation intended for technology assessment. In future PETT under development the achievement of a power density of 0.5–0.75 kVA/kg is expected.

Soft switching operation, where variation of the switching frequency is used to control the output voltage, would be allowed by the AC resonant circuit constituted by the capacitor  $C_r$  and the leakage inductance of the medium frequency transformer (Fig. 15). However, in the present PETT installation soft switching mode is not used and the converter operates at a fixed switching frequency of 1.75 kHz, which is below the resonance frequency.

Considering the features of the previously described structures, the two-module multi-phase NPC isolated DC/DC converter depicted in Fig. 16 is herein proposed. It merges the multi-phase topology of Fig. 13, the NPC-leg topology of Fig. 14 and the modular input-series-output-parallel topology of Fig. 15. It has the advantages of reducing voltage stress of components (thanks to the three-level NPC legs and the two-module structure), dividing current between more legs (thanks to the multi-phase structure) and enhancing fault tolerance (thanks to the multi-phase and modular structure). Technology for the realization of the converter could be borrowed from modern traction converters.

The two-module multi-phase NPC isolated DC/DC converter is particularly suitable for three-wire bipolar DC grids. When compared to unipolar DC systems, bipolar DC ones [181] have the advantage that the equipment requires a half-voltage insulation to ground and, if properly designed, the system is capable of emergency half-power operation with one of the two poles out of service.



for HVDC transmission lines with unidirectional power flow. Compared to other topologies, the two converters have a reduced number of active switches, which leads to lower price and higher efficiency.

In order to interconnect HVDC systems of different voltage levels, in [195] a MMDC with bidirectional fault blocking capability is proposed.

In [49] a protection scheme is proposed utilizing voltage-source converters as fast circuit breakers. It is demonstrated by simulations that faults can be detected and localized very quickly (within few milliseconds) employing smart relays associated with converters acting if current exceeds a certain threshold and lasts for a certain time interval. In [28,196,197] a fault detection method is proposed coordinating fully controllable power converters (which limit the current) with a set of contactors (which isolate the faulted section) to protect MVDC grids against short circuit faults.

Protection of DC power systems can also rely on DC CBs placed in strategic points with the purpose of breaking the short circuit current and isolating the branch where the fault has occurred.

A comparison of “unit-based” protection architectures (i.e. based on power converters coordinated with no-load electromechanical CBs) versus “breaker-based” ones is provided in [198]. “Unit-based” protection leads to lower cost and potentially reduced size and weight of the shipboard power system. On the other hand, simulation results show that “breaker-based” protection enhances reliability of power supply and survivability of the power system.

## 5.2. DC circuit breakers

CBs can be divided into three categories: mechanical, solid-state and hybrid, the last ones being constituted by the combination of a mechanical CB and a resonant circuit controlled by semiconductor devices.

The absence of natural current zero crossing and the low series impedance [191,192,199] makes fault current breaking in DC grids much more difficult than AC grids. As a consequence mechanical CBs are not suitable for DC grids, because they are not fast enough [191,192,199–201].

In [199,200] the problem of fault current interruption in MVDC and HVDC grids is examined, limitations of mechanical CBs are shown and different structures of solid-state and hybrid CBs are described. In [201] the differences between IGBT-based and IGCT-based solid-state CBs are discussed. In [202] the operation of an hybrid CB in a HVDC power system is analyzed, with the aim of finding out the influence that the CB and the system parameters have on the overcurrents and overvoltages following a breaking action.

A number of solid-state and hybrid CB prototypes can be found in the literature [203–215]. Many of them were conceived for MVDC power systems [203–211], one for protection of superconducting

magnets [212] and the others for HVDC power systems [213–215]. The solid-state CBs addressed in [207,213] and the hybrid CB presented in [215] are tested through reduced-scale prototypes. On the other hand, the solid-state CBs for MVDC shipboard power systems addressed in [205,206,209] and the hybrid CBs described in [203,204,210–212,214] are built up as full-scale prototypes. Finally, [208] proposes a CB employing a Z-source circuit to automatically switch-off a thyristor in response to a short circuit. The Z-source DC CB is built as a low-voltage prototype. Integration of Z-source DC CB into zonal-based MVDC shipboard distribution systems is studied in [216]. The proposed solutions are supported by simulations and experimental tests on a low-voltage prototype.

In addition to the ones described in [205,206,209], the full-scale bidirectional solid-state DC CB prototype shown in Fig. 17 has been built for the Italian Navy as a part of a MVDC distribution system technology demonstrator.

The solid-state DC CB is cooled by de-ionised water and has the following electrical specifications:

- rated line DC voltage 3000 V,
- maximum line voltage 3450 V,
- rated DC current 1400 A,
- ripple current < 10% of the rated current.

As shown by the circuit diagram in Fig. 17b, the DC CB is made bidirectional by connecting a unidirectional switch to a diode H-bridge (D11, D21, D31, D41). According to the available semiconductor devices, in order to fulfill the required voltage and current levels and assure safe sizing margins, the unidirectional switch is composed of four IGBTs (S1, S2, S3, S4) devices connected two-by-two in parallel and then in series.

The IGBTs are switched off immediately after receiving a turn off command. As a consequence, the current flows through the diodes D12, D22, D32, D42 into the capacitors C1, C2, C3, C4. The voltage of the capacitors is controlled by the auxiliary switches AS1, AS2, AS3, AS4 dissipating the turn off energy on the resistors R1, R2, R3, R4.

Dynamic voltage sharing between the series connected IGBTs is ensured during turnoff by the capacitors, so that a rough synchronization of the IGBT operation is sufficient.

Two trip settings make the CB open: (1) the current reaches the over-current limit, (2) the current growth rate exceeds the derivative limit.

Operation of the CB prototype was tested with voltage and current values higher than the rated ones. Experimental results of two tests are shown in Fig. 18. The first test was performed with a circuit imposing low current derivative (line inductance = 327  $\mu$ H), while the second

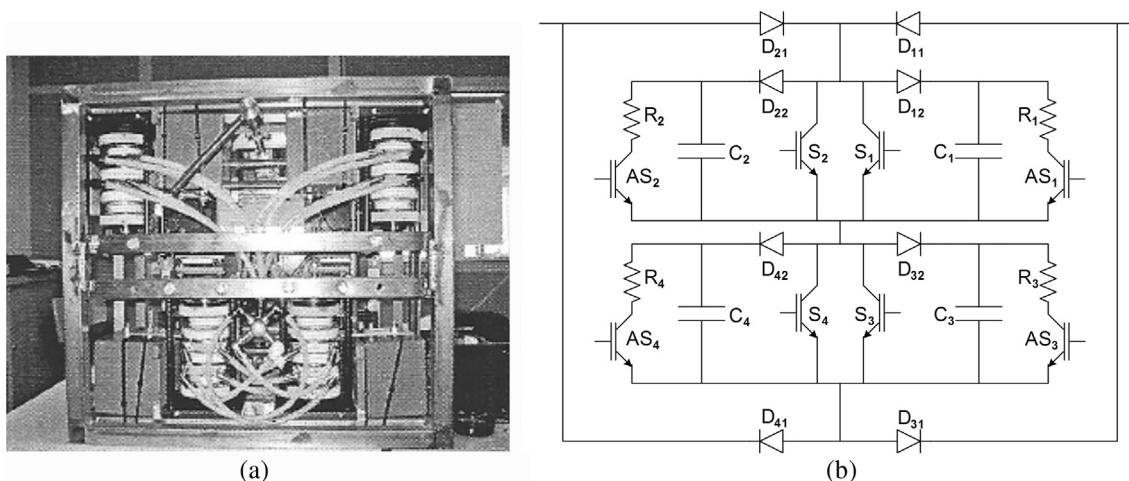
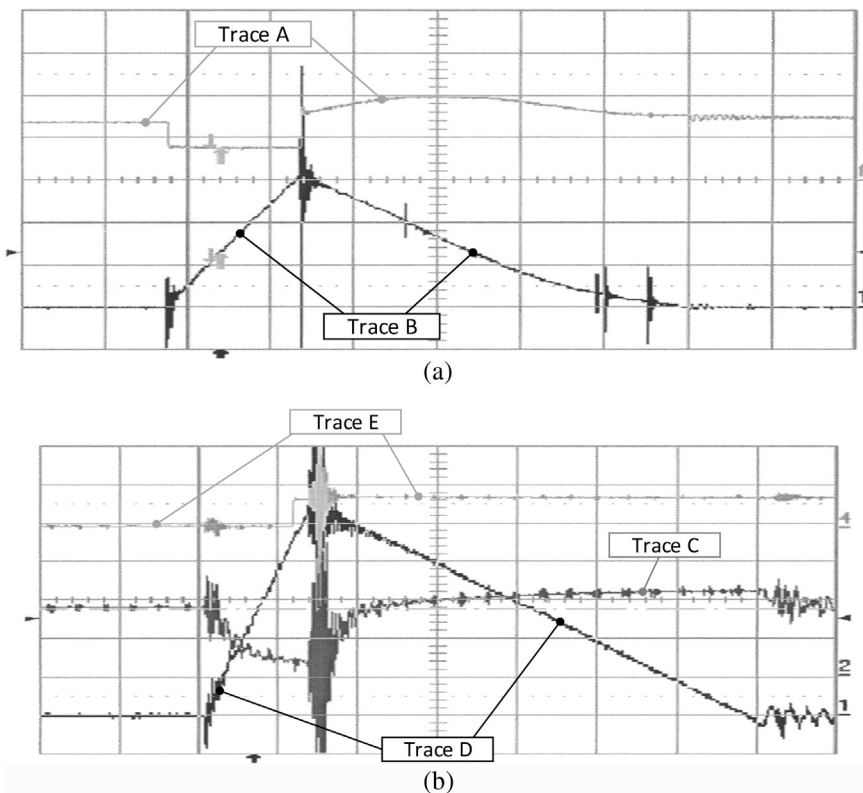

Fig. 17. 3 kV, 1.4 kA bidirectional solid-state CB: (a) picture of the full-scale prototype (width: 0.8 m, depth: 0.68 m, height: 0.74 m), (b) circuit diagram.



**Fig. 18.** (a) CB test with low current derivative: trace A = voltage ( $100\ \mu\text{s}/\text{div}$ ,  $1820\ \text{V}/\text{div}$ ), trace B = current ( $500\ \text{A}/\text{div}$ ). (b) CB test with high derivative: trace C = voltage ( $20\ \mu\text{s}/\text{div}$ ,  $1820\ \text{V}/\text{div}$ ), trace D = current ( $250\ \text{A}/\text{div}$ ), trace E = trip signal.

test was performed with a circuit imposing high current derivative (line inductance =  $2\ \mu\text{H}$ ).

During the first test the current derivative limit was set at  $30\ \text{A}/\mu\text{s}$ , over-current limit was set at  $1500\ \text{A}$ , and current setting for excessive current derivative was  $1350\ \text{A}$ .

Voltage (trace A) and current (trace B) versus time recorded during the first test are shown in Fig. 18a. After about  $150\ \mu\text{s}$  from the occurrence of the short circuit the current reaches  $1500\ \text{A}$  and the CB interrupts it. Results of the test show that the CB can effectively interrupt a current of  $1500\ \text{A}$  under a DC voltage of  $3300\ \text{V}$ .

During the second test the current derivative limit was set at  $10\ \text{A}/\mu\text{s}$ , over-current limit was set at  $1600\ \text{A}$ , and current setting for excessive current derivative was  $1000\ \text{A}$ .

Voltage (trace C), current (trace D) and tripping signal (trace E) versus time recorded during the second test are shown in Fig. 18b. The voltage is  $3250\ \text{V}$ . After about  $20\ \mu\text{s}$  from the occurrence of the short circuit the current reaches  $1000\ \text{A}$ . Due to the very high current derivative ( $45\ \text{A}/\mu\text{s}$ ) the tripping occurs with a small delay, about  $4\ \mu\text{s}$  after the current has reached  $1000\ \text{A}$ , i.e. when the current has reached about  $1200\ \text{A}$ , while the breaking action becomes effective when the current has reached about  $1400\ \text{A}$ . However, the test was successful because it demonstrates that the CB is able to effectively intervene when a high derivative current is occurring, independently of the over-current trip setting.

From Fig. 18 it can be seen that fault clearance time is in the order of tens of microseconds, consistently with the usual characteristic performance expected for DC CBs [209].

## 6. Conclusion

Power electronics plays a key role in MVDC power systems. Technology is nowadays going to become mature enough to make MVDC power systems for AES a realistic alternative to MVAC power systems. Realization costs are still higher than MVAC power systems, but the expected benefits are such to attract the interest of shipbuilders, who want to be ready to provide their ships with MVDC power system when the technology will be mature enough and the scale production

will make it affordable.

In this paper a survey has been provided of the most promising technologies for power electronics equipment to be employed in ship-board MVDC power systems. The power electronics equipment has been classified according to the IEEE Std 1709™-2010 into three subsystems, namely power sources, load centers and distribution network.

Regarding power sources, power converters for power generation, energy storage and shore power interface are presented. In particular, different kinds of DC generation systems have been described also making reference to some built and tested full-scale prototypes specifically conceived for MVDC military vessels. It has been highlighted how the choice of the converter is closely connected to the adopted electric generator technology.

Regarding load centers, power converters for propulsion, ship services, dedicated high power loads and pulse loads are presented. Attention is particularly focused on step-down SSTs which interconnect ship services to the MVDC bus. A detailed classification has been presented for the large number of step-down DC/DC converters found in the literature highlighting the features which particularly fit to serve as SSTs. Finally, combining three existing topologies, a new SST architecture has been proposed exhibiting the following benefits: (1) fault tolerance, thanks to the multi-phase and modular structure, (2) design and realization advantages, thanks to the energy flow sharing between multiple converter legs and modules, (3) voltage subdivision, thanks to the NPC legs and modular structure, (4) limited losses, thanks to the resonant AC circuit.

Regarding the distribution network, it has been emphasized how one of the most critical issues making MVDC power systems implementation challenging is electrical protection, owing to the difficulty of DC current breaking in case of a short circuit event. It has been remarked that power converters necessarily employed in MVDC power systems can be of large help in the limitation and interruption of fault currents. Moreover, several dedicated CBs for MVDC and HVDC applications have been comparatively reviewed. Test results have been reported for a full-scale solid-state DC CB prototype developed for ship-board MVDC systems.

## References

- [1] Saeedifard M, Graovac M, Dias RF, Irvani R. DC power systems: challenges and opportunities. Proc power and energy society general meeting. 2010. p. 1–7.
- [2] Jovcic D, Van Herthem D, Linden K, Taisne JP, Grieshaber W. Feasibility of DC transmission networks. Proc IEEE PES international conference and exhibition on innovative smart grid technologies (ISGT Europe). 2011. p. 1–8.
- [3] Eriksson K. Operational experience of HVDC Light™. Proc. international conference on AC-DC power transmission. 2001. p. 205–10.
- [4] Prasher VK, Kumar D, Bartzsch C, Hartmann V, Mukherjee A. HVDC east-south interconnector II in India: 2000MW, ± 500 kV. Proc. international conference on AC-DC power transmission. 2001. p. 78–83.
- [5] Ingemansson D, Wheeler JD, MacLeod NM, Gallon F, Ruiton O. The south – west scheme: a new HVAC and HVDC transmission system in Sweden. Proc. IET international conference on AC and DC power transmission. 2012. p. 1–5.
- [6] Herbst JD, Gattozzi AL, Ouroua A, Uriarte FM. Flexible test bed for MVDC and HFAC electric ship power system architectures for navy ships. Proc. IEEE electric ship technologies symposium (ESTS). 2011. p. 66–71.
- [7] Dragicic T, Lu X, Vasquez JC, Guerrero JM. DC microgrids — Part II: a review of power architectures, applications, and standardization issues. IEEE Trans Power Electron 2016;31(5):3528–49.
- [8] Elsayed AT, Mohamed AA, Mohammed OA. DC microgrids and distribution systems: an overview. Electr Power Syst Res 2015;119:407–17.
- [9] Ericson T, Hingorani N, Khersonsky Y. Power electronics and future marine electrical systems. IEEE Trans Industr Appl 2006;42(1):155–63.
- [10] Baran ME, Mahajan NR. DC distribution for industrial systems: opportunities and challenges. IEEE Trans Industr Appl 2003;39(6):1596–601.
- [11] Kwaskinski A. Advanced power electronics enabled distribution architectures: design, operation, and control. Proc. international conference on power electronics and ECCE Asia (ICPE & ECCE). 2011. p. 1484–91.
- [12] Davidson C, de Preville G. The future of high power electronics in transmission and distribution power systems. Proc. European conference on power electronics and applications (EPE). 2009. p. 1–14.
- [13] Ericson T. The ship power electronic revolution: issues and answers. Proc. petroleum and chemical industry technical conference (PCIC). 2008. p. 1–11.
- [14] De Doncker R,W, Meyer C, Lenke R,U, Mura F. Power electronics for future utility applications. Proc. international conference on power electronics and drive systems (PEDS). 2007. p. K-1–8.
- [15] Reed GF, Grainger BM, Sparacino AR, Mao ZH. Ship to grid – medium-voltage DC concepts in theory and practice. IEEE Power Energy Mag 2012;10(6):70–9.
- [16] Khersonsky Y, Hingorani N, Peterson KL. IEEE electric ship technologies initiatives. IEEE Indust Appl Mag 2011;17(1):65–73.
- [17] Doerry N, Amy J, Krolick C. History and the status of electric ship propulsion, integrated power systems, and future trends in the U.S. Navy. Proc IEEE 2015;103(12):2243–51.
- [18] McCoy TJ. Integrated power systems – an outline of requirements and functionalities for ships. Proc IEEE 2015;103(12):2276–84.
- [19] Sudhoff SD. Currents of change. IEEE Power Energy Mag 2011;9(4):30–7.
- [20] Jin Z, Sulligoi G, Cuzner R, Meng L, Vasquez JC, Guerrero JM. Next-generation shipboard DC power system – introducing smart grid and dc microgrid technologies into maritime electrical networks. IEEE Electrif Mag 2016;4(2):45–57.
- [21] IEEE Recommended Practice for 1 kV to 35 kV Medium-Voltage DC Power Systems on Ships, IEEE Std 1709™-2010; November 2010. p. 1–44.
- [22] Geertsma RD, Negenborn RR, Visser K, Hopman JJ. Design and control of hybrid power and propulsion systems for smart ships: a review of developments. Appl Energy 2017;194:30–54.
- [23] Doerry N. Naval power systems – integrated power systems for the continuity of the electrical power supply. IEEE Electrif Mag 2015;3(2):12–21.
- [24] Kanellos FD, Tsekouras GJ, Prousalidis J. Onboard DC grid employing smart grid technology: challenges, state of the art and future prospects. IET Electr Syst Transp 2015;5(1):1–11.
- [25] Tassarolo A, Castellani S, Menis R, Sulligoi G. Electric generation technologies for all-electric ships with medium-voltage DC power distribution systems. Proc. electric ship technologies symposium. 2013. p. 275–81.
- [26] Woodyard D. Pounder's marine diesel engines and gas turbines 9th ed. Elsevier; 2009.
- [27] Sulligoi G, Vicenzutti A, Menis R. All-electric ship design: from electrical propulsion to integrated electrical and electronic power systems. IEEE Trans Transp Electrif 2016;2(4):507–21.
- [28] Cairolì P, Dougal RA. New horizons in DC shipboard power systems – new fault protection strategies are essential to the adoption of DC power systems. IEEE Electrif Mag 2013;1(2):38–45.
- [29] Cupelli M, Ponci F, Sulligoi G, Vicenzutti A, Edrington CS, El-Mezyani T, et al. Power flow control and network stability in an all-electric ship. Proc IEEE 2015;103(12):2355–80.
- [30] Javaid U, Freijedo FD, Dujic D, Van der Merwe W. Dynamic assessment of source-load interactions in marine MVDC distribution. IEEE Trans Industr Electron 2017;64(6):4372–81.
- [31] Javaid U, Dujic D, van der Merwe W. MVDC marine electrical distribution: are we ready? Proc. annual conference of the IEEE industrial electronics society. 2015. p. 823–8.
- [32] She X, Huang AQ, Burgos R. Review of solid-state transformer technologies and their application in power distribution systems. IEEE J Emerg Sel Top Power Electron 2013;1(3):186–98.
- [33] Puglise H, Von Kannewerff M. Discovering DC – a primer on DC circuit breakers, their advantages, and design. IEEE Indust Appl Mag 2013;19(5):22–8.
- [34] Buja G, Menis R. Dependability and functional safety. IEEE Indust Electron Mag 2012;6(3):4–12.
- [35] Vicenzutti A, Bosich D, Pelaschiar R, Menis R, Sulligoi G. Increasing the safety of modern passenger ships: a comprehensive approach for designing safe shipboard integrated electrical power systems. IEEE Electrif Mag 2017;5(3):40–54.
- [36] Wang F, Zhang Z, Ericson T, Raju R, Burgos R, Boroyevich D. Advances in power conversion and drives for shipboard systems. Proc IEEE 2015;103(12):2285–311.
- [37] Tassarolo A, Castellani S, Menis R, Sulligoi G. Fault tolerant electric generation systems for DC distribution network supply. Proc. AEIT annual conference – from research to industry: the need for a more effective technology transfer (AEIT). 2014. p. 1–5.
- [38] Sulligoi G, Tassarolo A, Benucci V, Millerani Trapani A, Baret M, Luise F. Shipboard power generation – design and development of a medium-voltage dc generation system. IEEE Indust Appl Mag 2013;19(4):47–55.
- [39] Sattler G. PEFCs for naval ships and submarines: many tasks, one solution. J Power Sources 1998;71(1–2):144–9.
- [40] van Biert L, Godjevac M, Visser K, Aravind PV. A review of fuel cell systems for maritime applications. J Power Sources 2016;327:345–64.
- [41] Aizza M, Bosich D, Castellani S, Menis R, Sulligoi G, Tassarolo A. Coordinated speed and voltage regulation of a dc power generation system based on a woundfield split-phase generator supplying multiple rectifiers. Proc. IET international conference on power electronics, machines and drives (PEMD). 2012. p. 1–6.
- [42] Sulligoi G, Tassarolo A, Benucci V, Baret M, Rebrora A, Taffone A. Modeling, simulation, and experimental validation of a generation system for medium-voltage DC integrated power systems. IEEE Trans Industr Appl 2010;46(4):1304–10.
- [43] Wang Y, Deng Z. Hybrid excitation topologies and control strategies of stator permanent magnet machines for DC power system. IEEE Tran Industr Electron 2012;59(2):4601–16.
- [44] Mbayed R, Salloum G, Vido L, Monmasson E, Gabsi M. Control of a hybrid excitation synchronous generator connected to a diode bridge rectifier supplying a DC bus in embedded applications. IET Electr Power Appl 2013;7(1):68–76.
- [45] Castellani S, Tassarolo A, Bortolozzi M, Mezzarobba M. Analysis of asymmetrical short circuits downstream of 12 pulse diode rectifier fed by double three phase synchronous machines. Proc. IET international conference on power electronics, machines and drives. 2014. p. 1–5.
- [46] Ahmed T, Nishida K, Nakaoka M. A novel stand-alone induction generator system for AC and DC power generation. IEEE Trans Industr Appl 2007;43(6):1465–74.
- [47] Dong D, Pan Y, Lai R, Wu X, Weeber K. Active fault-current foldback control in thyristor rectifier for DC shipboard electrical system. IEEE J Emerg Sel Top Power Electron 2017;5(1):203–12.
- [48] Singh B, Niwas R, Dube SK. Load leveling and voltage control of permanent magnet synchronous generator-based DG set for standalone supply system. IEEE Trans Industr Informat 2014;10(4):2034–43.
- [49] Baran ME, Mahajan NR. Overcurrent protection on voltage-source-converter-based multiterminal DC distribution systems. IEEE Trans Power Deliv 2007;22(1):406–12.
- [50] Hajian M, Jovcic D, Wu B. Evaluation of semiconductor based methods for fault isolation on high voltage DC grids. IEEE Trans Smart Grids 2013;4(2):1171–9.
- [51] Magureanu R, Albu M, Bostan V, Doka A-I. Synchronous and induction generators operating at variable speed in DC networks. In: Proc. international conference on electrical machines (ICEM), Paper ID 1347; 2008. p. 1–6.
- [52] Kollensperger P, Meyer C, Schwarzer U, Schroder S, De Doncker RW. High-power converter systems for high-speed generators. Proc. European conference on power electronics and applications. 2005. p. 1–9.
- [53] Luise F, Pieri S, Mezzarobba M, Tassarolo A. Regenerative testing of a concentrated-winding permanent-magnet synchronous machine for off-shore wind generation – Part I: test concept and analysis. IEEE Trans Industr Appl 2012;8(6):1779–90.
- [54] Luise F, Pieri S, Mezzarobba M, Tassarolo A. Regenerative testing of a concentrated-winding permanent-magnet synchronous machine for off-shore wind generation – Part II: test results. IEEE Trans Industr Appl 2012;8(6):1791–6.
- [55] Kolar JW, Friedli T. The essence of three-phase PFC rectifier systems—Part I. IEEE Trans Power Electron 2013;28(1):176–98.
- [56] Friedli T, Hartmann M, Kolar JW. The essence of three-phase PFC rectifier systems—Part II. IEEE Trans Power Electron 2014;29(2):176–98.
- [57] Buja G, Castellani S. Sizing and control of a three-phase PWM rectifier with reduced switch count. Proc. international conference on electrical drives and power electronics. 2001. p. 194–9.
- [58] Farhadi M, Mohammed O. Energy storage technologies for high-power applications. IEEE Trans Industr Appl 2016;52(3):1953–61.
- [59] Tan X, Li Q, Wang H. Advances and trends of energy storage technology in microgrid. Int J Electr Power Energy Syst 2013;44(1):179–91.
- [60] Hansen JF, Wendt F. History and state of the art in commercial electric ship propulsion, integrated power systems, and future trends. Proc IEEE 2015;103(12):2229–42.
- [61] Zahedi B, Norum LE, Ludvigsen KB. Optimized efficiency of all-electric ships by dc hybrid power systems. J Power Sources 2014;255:341–54.
- [62] Lashway CR, Elsayed AT, Mohammed OA. Hybrid energy storage management in ship power systems with multiple pulsed loads. Electr Power Syst Res 2016;141:50–62.
- [63] Mo R, Li H. Hybrid energy storage system with active filter function for shipboard MVDC system applications based on isolated modular multilevel DC/DC converter. IEEE J Emerg Sel Top Power Electron 2017;5(1):79–87.
- [64] Divya KC, Østergaard J. Battery energy storage technology for power systems—an overview. Electr Power Syst Res 2009;79(4):511–20.

- [65] Bolborici V, Dawson FP, Lian KK. Hybrid energy storage systems: connecting batteries in parallel with ultracapacitors for higher power density. *IEEE Indust Appl Mag* 2014;20(4):31–40.
- [66] Khan MMS, Faruque MO, Newaz A. Fuzzy logic based energy storage management system for MVDC power system of all electric ship. *IEEE Trans Energy Convers* 2017;32(2):798–809.
- [67] Tang Y, Khaligh A. Bidirectional hybrid battery/ultracapacitor energy storage systems for next generation MVDC shipboard power systems. *Proc. IEEE vehicle power and propulsion conference*. 2011. p. 1–6.
- [68] Khodadoost Arani AA, Karami H, Gharehpetian GB, Hejazi MSA. Review of fly-wheel energy storage systems structures and applications in power systems and microgrids. *Renew Sustain Energy Rev* 2017;69:9–18.
- [69] Mousavi SM, Faramarz Faraji, Abbas Majazi, Kamal Al-Haddad. A comprehensive review of flywheel energy storage system technology. *Renew Sustain Energy Rev* 2017;67:477–90.
- [70] Grainger BM, Reed GF, Sparacino AR, Lewis PT. Power electronics for grid-scale energy storage. *Proc IEEE* 2014;102(6):1000–13.
- [71] Wang G, Konstantinou G, Townsend CD, Pou J, Vazquez S, Demetriades GD, et al. A review of power electronics for grid connection of utility-scale battery energy storage systems. *IEEE Trans Sustain Energy* 2016;7(4):1778–90.
- [72] Inoue S, Akagi H. A bidirectional DC–DC converter for an energy storage system with galvanic isolation. *IEEE Trans Power Electron* 2007;22(6):2299–306.
- [73] Rodriguez J, Bernet S, Steimer PK, Lizama IE. A survey on neutral-point-clamped inverters. *IEEE Trans Industr Electron* 2010;57(7):2219–30.
- [74] Malinowski M, Gopakumar K, Rodriguez J, Pérez MA. A survey on cascaded multilevel inverters. *IEEE Trans Industr Electron* 2010;57(7):2197–206.
- [75] Rodriguez J, Lai JS, Peng FZ. Multilevel inverters: a survey of topologies, controls, and applications. *IEEE Trans Industr Electron* 2002;49(4):724–38.
- [76] Kouro S, Malinowski M, Gopakumar K, Pou J, Franquelo LG, Wu B, et al. Recent advances and industrial applications of multilevel converters. *IEEE Trans Industr Electron* 2010;57(8):2553–80.
- [77] Abu-Rub H, Holtz J, Rodriguez J, Baoming G. Medium-voltage multilevel converters – state of the art, challenges, and requirements in industrial applications. *IEEE Trans Industr Electron* 2010;57(8):2581–96.
- [78] Benato R, Cosciani N, Crugnola G, Dambone Sessa S, Lodi G, Parmeggiani C, et al. Sodium nickel chloride battery technology for large-scale stationary storage in the high voltage network. *J Power Sources* 2015;293:127–36.
- [79] Andriollo M, Benato R, Dambone Sessa S, Di Pietro N, Hirai N, Nakanishi Y, et al. Energy intensive electrochemical storage in Italy: 34.8 MW sodium–sulphur secondary cells. *J Energy Storage* 2016;5:146–55.
- [80] Andriollo M, Benato R, Bressan M, Dambone Sessa S, Palone F, Polito RM. Review of power conversion and conditioning systems for stationary electrochemical storage. *Energies MDPI* 2015;8(2):960–75.
- [81] Guarnieri M, Mattavelli P, Petrone G, Spagnuolo G. Vanadium redox flow batteries: potentials and challenges of an emerging storage technology. *IEEE Indust Electron Mag* 2016;10(4):20–31.
- [82] Peterson KL, Chavdarian P, Islam M, Cayanan C. Tackling ship pollution from the shore. *IEEE Indust Appl Mag* 2009;15(1):56–60.
- [83] Yangl X, Bail G, Schmidhalter R. Shore to ship converter system for energy saving and emission reduction. *Proc. international conference on power electronics and ECCE Asia*. 2011. p. 2081–6.
- [84] Sulligoi G, Bosich D, Pelaschiar R, Lipardi G, Tosato F. Shore-to-ship power. *Proc IEEE* 2015;103(12):2381–400.
- [85] Khersonsky Y, Islam M, Peterson K. Challenges of connecting shipboard marine systems to medium voltage shoreside electrical power. *IEEE Trans Industr Appl* 2007;43(3):838–44.
- [86] Paul D, Haddadian V. Transient overvoltage protection of shore-to-ship power supply system. *IEEE Trans Industr Appl* 2011;47(3):1193–200.
- [87] Sulligoi G, Bosich D, Da Rin A, Tosato F. An examination of mutual influences between high-voltage shore-connected ships and port earthing systems during phase-to-ground faults. *IEEE Trans Industr Appl* 2012;48(5):1731–8.
- [88] Paul D, Peterson K, Chavdarian PR. Designing cold ironing power systems: electrical safety during ship berthing. *IEEE Indust Appl Mag* 2014;20(3):24–32.
- [89] Chou MH, Su CL, Lee YC, Chin HM, Parise G, Chavdarian PR. Voltage-drop calculations and power cable designs for harbor electrical distribution systems with high voltage shore connection. *IEEE Trans Industr Appl* 2017;53(3):1807–14.
- [90] Kroposki B, Pink C, DeBlasio R, Thomas H, Simões M, Sen PK. Benefits of power electronic interfaces for distributed energy systems. *IEEE Trans Energy Convers* 2010;25(3):901–8.
- [91] Strzelecki R, Mysiak P, Sak T. Solutions of inverter systems in shore-to-ship power supply systems. *Proc. international conference on compatibility and power electronics*. 2015. p. 454–61.
- [92] Arillaga J, Watson NR. *Power system harmonics* 2nd ed. Chichester, West Sussex, England: John Wiley & Sons Ltd; 2003.
- [93] Gritter D, Kalsi SS, Henderson N. Variable speed electric drive options for electric ships. *Proc. IEEE electric ship technologies symposium (ESTS)*. 2005. p. 347–54.
- [94] McCoy TJ, Amy JV. The state-of-the-art of integrated electric power and propulsion systems and technologies on ships. *Proc. IEEE electric ship technologies symposium (ESTS)*. 2009. p. 340–4.
- [95] Castellán S, Tassarolo A. High-power electric drives for all-electric ships. *Proc. international conference on ecological vehicles and renewable energies (EVER)*. 2010. p. 1–6. CD paper no. 340.
- [96] Thantirige K, Rathore AK, Panda SK, Jayasignhe G, Zagrodnik MA, Gupta AK. Medium voltage multilevel converters for ship electric propulsion drives. *Proc. international conference on electrical systems for aircraft, railway, ship propulsion and road vehicles (ESARS)*. 2015. p. 1–7.
- [97] Castellán S, Menis R, Pigani M, Sulligoi G, Tassarolo A. Modeling and simulation of electric propulsion systems for all-electric cruise liners. *Proc. IEEE electric ship technologies symposium (ESTS)*. 2007. p. 60–4.
- [98] Castellán S, Quaiá S, Scialla P, Sulligoi G. All-electric mega-yachts: integrated power system operation and its interaction with propulsion converters. *Proc. international symposium on power electronics, electrical drives, automation and motion (SPEEDAM)*. 2006. p. 317–22.
- [99] Chen Y, Li Z, Zhao S, Wei X, Kang Y. Design and implementation of a modular multilevel converter with hierarchical redundancy ability for electric ship MVDC system. *IEEE J Emerg Sel Top Power Electron* 2017;5(1):189–202.
- [100] Rodriguez J, Bernet S, Wu B, Pontt JO, Kouro S. Multilevel voltage-source-converter topologies for industrial medium-voltage drives. *IEEE Trans Industr Electron* 2007;54(6):2930–45.
- [101] Hiller M, Sommer R, Beuermann M. Medium-voltage drives: an overview of the common converter topologies and power semiconductor devices. *IEEE Indust Appl Mag* 2010;16(2):22–30.
- [102] Kouro S, Rodriguez J, Wu B, Bernet S, Perez M. Powering the future of industry – high-power adjustable speed drive topologies. *IEEE Indust Appl Mag* 2012;18(4):26–39.
- [103] Abu-Rub H, Bayhan S, Moinoddin S, Malinowski M, Guzinski J. Medium-voltage drives: challenges and the existing technology. *IEEE Power Electron Mag* 2016;3(2):29–41.
- [104] Reusser CA, Young H. Full electric ship propulsion based on a flying capacitor converter and an induction motor drive. *Proc. international conference on electrical systems for aircraft, railway, ship propulsion and road vehicles (ESARS)*. 2015. p. 1–6.
- [105] Spichartz M, Staudt V, Steimel A. Modular multilevel converter for propulsion system of electric ships. *Proc. IEEE electric ship technologies symposium (ESTS)*. 2013. p. 237–42.
- [106] Adnanes AK. A survey of concepts for electric propulsion in conventional and ice breaking OSVs. *Proc. propulsion & emission conference*. 2008. p. 1–19.
- [107] Manuelle P, Singam B, Siala S. Induction motors fed by PWM MV7000 converters enhance electric propulsion performance. *Proc. European conference on power electronics and applications*. 2009. p. 1–9.
- [108] Leclere L, Galmiche C. A transformerless full redundant electrical propulsion solution to enhance power density, availability and low noise signature. *Proc. IEEE electric ship technologies symposium (ESTS)*. 2011. p. 296–9.
- [109] Guennegues V, Gollentz B, Meibody-Tabar F, Raël S, Leclere L. A converter topology for high speed motor drive applications. *Proc. European conference on power electronics and applications*. 2009. p. 1–8.
- [110] Kanerva S, Hansen JF. State of the art in electric propulsion – viewpoint on redundancy. *Proc. IEEE electric ship technologies symposium (ESTS)*. 2009. p. 499–504.
- [111] Bojoi R, Rubino S, Tenconi A, Vaschetto S. Multiphase electrical machines and drives: a viable solution for energy generation and transportation electrification. *Proc. international conference and exposition on electrical power engineering (EPE)*. 2016. p. 632–9.
- [112] Chaitanya MA, Maswood AI, Yeong LM, Gupta AK. Realisation of ‘more electric ships’ through a modular, efficient, tank-less and non-resonant inverter. *IET Power Electron* 2016;9(4):771–81.
- [113] Reusser CA, Young H. Nine-switch converter application on electric ship propulsion – a redundancy approach. *Proc. international conference on electrical systems for aircraft, railway, ship propulsion and road vehicles (ESARS)*. 2016. p. 1–7.
- [114] Liu Z, Zheng Z, Li Y. Enhancing fault-tolerant ability of nine-phase induction motor drive system using fuzzy logic current controllers. *IEEE Trans Energy Convers* 2017;32(2):759–69.
- [115] Sulligoi G, Castellán S, Aizza M, Bosich D, Piva L, Lipardi G. Active front-end for shaft power generation and voltage control in FREMM frigates integrated power system: modeling and validation. *Proc. international symposium on power electronics, electrical drives, automation and motion (SPEEDAM)*. 2012. p. 452–7.
- [116] SINAVY DC-Prop and SINAVY PERMASYN® – Integrated propulsion solutions for submarines, Siemens AG, 2016, brochure available at: <<https://www.industry.siemens.com/verticals/global/en/marine/marine-ships/propulsion/pages/propulsion.aspx>>.
- [117] Jovicic D. Bidirectional, high-power DC transformer. *IEEE Trans Power Deliv* 2009;24(4):2276–83.
- [118] Adam GP, Gowaid IA, Finney SJ, Holliday D, Williams BW. Review of dc-dc converters for multi-terminal HVDC transmission networks. *IET Power Electron* 2016;9(2):281–96.
- [119] Rodrigues JP, Mussa SA, Heldwein ML, Perin AJ. Three-level ZVS active clamping PWM for the DC–DC buck converter. *IEEE Trans Power Electron* 2009;24(10):2249–58.
- [120] Ferreira Costa L, Mussa SA, Barbi I. Multilevel buck/boost-type DC–DC converter for high-power and high-voltage application. *IEEE Trans Industr Appl* 2014;50(6):3931–42.
- [121] Perez MA, Bernet S, Rodriguez J, Kouro S, Lizana R. Circuit topologies, modeling, control schemes, and applications of modular multilevel converters. *IEEE Trans Power Electron* 2015;30(1):4–17.
- [122] Debnath S, Qin J, Bahrani B, Saadedifar M, Barbosa P. Operation, control, and applications of the modular multilevel converter: a review. *IEEE Trans Power Electron* 2015;30(1):37–53.
- [123] Montesinos-Miracle D, Massot-Campos M, Bergas-Jan’e J, Galceran-Arellano S, Rufer A. Design and control of a modular multilevel DC/DC converter for regenerative applications. *IEEE Trans Power Electron* 2013;28(8):3970–9.
- [124] Ferreira JA. The multilevel modular DC converter. *IEEE Trans Power Electron* 2013;28(10):4460–5.



- [125] Hagar AA, Lehn PW. Comparative evaluation of a new family of transformerless modular DC–DC converters for high-power applications. *IEEE Trans Power Deliv* 2014;29(1):444–52.
- [126] Zhang X, Green TC, Junyent-Ferré A. A new resonant modular multilevel step-down DC–DC converter with inherent-balancing. *IEEE Trans Power Electron* 2015;30(1):78–88.
- [127] Filsoof K, Lehn PW. A bidirectional modular multilevel DC–DC converter of triangular structure. *IEEE Trans Power Electron* 2015;30(1):54–64.
- [128] Engel SP, Stieneker M, Soltan N, Rabiee S, Stagge H, De Doncker RW. Comparison of the modular multilevel DC converter and the dual-active bridge converter for power conversion in HVDC and MVDC grids. *IEEE Trans Power Electron* 2015;30(1):124–37.
- [129] De Doncker RWAA, Divan DM, Kheraluwala MH. A three-phase soft-switched high-power-density dc/dc converter for high-power applications. *IEEE Trans Industr Appl* 1991;27(1):63–73.
- [130] Jovcic D, Ooi BT. Developing DC transmission networks using DC transformers. *IEEE Trans Power Deliv* 2010;25(4):2535–43.
- [131] Hajian M, Robinson J, Jovcic D, Bin Wu. 30 kW, 200 V/900 V, thyristor LCL DC/DC converter laboratory prototype design and testing. *IEEE Trans Power Electron* 2014;29(3):1094–102.
- [132] Jovcic D, Zhang L. LCL DC/DC converter for DC grids. *IEEE Trans Power Deliv* 2013;28(4):2071–9.
- [133] Zhang J, Zhang F, Xie X, Jiao D, Qian Z. A novel ZVS DC/DC converter for high power applications. *IEEE Trans Power Electron* 2004;19(2):420–9.
- [134] Oliveira Jr. DS, Barbi Ivo. A three-phase ZVS PWM DC/DC converter with asymmetrical duty cycle for high power applications. *IEEE Trans Power Electron* 2005;20(2):370–7.
- [135] Oliveira Jr. DS, Barbi Ivo. A three-phase ZVS PWM DC/DC converter with asymmetrical duty cycle associated with a three-phase version of the hybrid rectifier. *IEEE Trans Power Electron* 2005;20(2):354–60.
- [136] Jacobs J, Averberg A, De Doncker RW. Multi-phase series resonant DC-to-DC converters: stationary investigations. *Proc. power electronics specialists conference (PESC)*. 2005. p. 660–6.
- [137] Jacobs J, Averberg A, Schroder S, De Doncker RW. Multi-phase series resonant DC-to-DC converters: transient investigations. *Proc. power electronics specialists conference (PESC)*. 2005. p. 1972–8.
- [138] Pinheiro JR, Barbi I. The three-level ZVS-PWM DC-to-DC Converter. *IEEE Trans Power Electron* 1993;8(4):486–92.
- [139] Ruan X, Zhou L, Yan Y. Soft-switching PWM three-level converters. *IEEE Trans Power Electron* 2001;16(5):612–22.
- [140] Ruan X, Xu D, Zhou L, Li B, Chen Q. Zero-voltage-switching PWM three-level converter with two clamping diodes. *IEEE Trans Industr Electron* 2002;49(4):790–9.
- [141] Canales F, Barbosa P, Lee FC. A zero-voltage and zero-current switching three-level DC/DC converter. *IEEE Trans Power Electron* 2002;17(6):898–904.
- [142] Song BM, McDowell R, Bushnell A, Ennis J. A three-level DC–DC converter with wide-input voltage operations for ship-electric-power-distribution systems. *IEEE Trans Plasma Sci* 2004;32(5):1856–63.
- [143] Ruan X, Li B. Zero-voltage and zero-current-switching PWM hybrid full-bridge three-level converter. *IEEE Trans Industr Electron* 2005;52(1):213–20.
- [144] Gu Y, Lu Z, Hang L, Qian Z, Huang G. Three-level LLC series resonant DC/DC converter. *IEEE Trans Power Electron* 2005;20(4):781–9.
- [145] Song T, Huang N, Ioinovici A. A family of zero-voltage and zero-current-switching (ZVZCS) three-level DC–DC converters with secondary-assisted regenerative passive snubber. *IEEE Trans Circ Syst I: Regular Pap* 2005;52(11):2473–81.
- [146] Song T, Huang N, Ioinovici A. A zero-voltage and zero-current switching three-level DC–DC converter with reduced rectifier voltage stress and soft-switching-oriented optimized design. *IEEE Trans Power Electron* 2006;21(5):1204–12.
- [147] Ghodke DV, Chatterjee K, Fernandes BG. Three-phase three level, soft switched, phase shifted PWM DC–DC converter for high power applications. *IEEE Trans Power Electron* 2008;23(3):1214–27.
- [148] Liu F, Yan J, Ruan X. Zero-voltage and zero-current-switching PWM combined three-level DC/DC converter. *IEEE Trans Industr Electron* 2010;57(5):1644–54.
- [149] Ghodke DV, Chatterjee K, Fernandes BG. Modified soft-switched three-phase three-level DC–DC converter for high-power applications having extended duty cycle range. *IEEE Trans Industr Electron* 2012;59(9):3362–72.
- [150] Lin BR, Chao CH. Soft switching DC/DC converter for high-input voltage and medium-power applications. *IET Power Electron* 2012;5(9):1892–903.
- [151] Lin BR, Chung SK, Shiao TY. Zero-voltage-switching DC/DC converter with three-level pulse-width modulation circuit cells. *IET Power Electron* 2013;6(1):1–8.
- [152] Lin BR, Chien CC. Analysis and implementation of a new soft switching DC/DC PWM converter. *IET Power Electron* 2013;6(1):202–13.
- [153] Deng F, Chen Z. Control of improved full-bridge three-level DC/DC converter for wind turbines in a DC grid. *IEEE Trans Power Electron* 2013;28(1):314–24.
- [154] Lin BR, Chao CH. Analysis, design, and implementation of a soft-switching converter with two three-level PWM circuits. *IEEE Trans Power Electron* 2013;28(4):1700–9.
- [155] Lin BR, Chao CH. Analysis of an interleaved three-level ZVS converter with series-connected transformers. *IEEE Trans Power Electron* 2013;28(7):3088–99.
- [156] Shi Y, Yang X. Zero-voltage switching PWM three-level full-bridge DC–DC converter with wide ZVS load range. *IEEE Trans Power Electron* 2013;28(10):4511–24.
- [157] Lin BR, Chien CC. Zero voltage switching DC converter for high-input voltage and high-load current applications. *IET Power Electron* 2014;7(1):124–31.
- [158] Liu F, Hu G, Ruan X. Three-phase three-level DC/DC converter for high input voltage and high power applications – adopting symmetrical duty cycle control. *IEEE Trans Power Electron* 2014;29(1):56–65.
- [159] Shi Y, Yang X. Wide range soft switching PWM three-level DC–DC converters suitable for industrial applications. *IEEE Trans Power Electron* 2014;29(2):603–16.
- [160] Chu E, Hou X, Zhang H, Wu M, Liu X. Novel zero-voltage and zero-current switching (ZVZCS) PWM three-level DC/DC converter using output coupled inductor. *IEEE Trans Power Electron* 2014;29(3):1082–92.
- [161] Shi Y, Yang X. Wide-range soft-switching PWM three-level combined DC–DC converter without added primary clamping devices. *IEEE Trans Power Electron* 2014;29(10):5157–71.
- [162] Liu F, Chen Y, Hu G, Ruan X. Modified three-phase three-level DC/DC converter with zero-voltage-switching characteristic – adopting asymmetrical duty cycle control. *IEEE Trans Power Electron* 2014;29(12):6307–18.
- [163] Li W, Jiang Q, Mei Y, Li C, Deng Y, He X. Modular multilevel DC/DC converters with phase-shift control scheme for high-voltage DC-based systems. *IEEE Trans Power Electron* 2015;30(1):99–107.
- [164] Nami A, Liang J, Dijkhuizen F, Demetriades GD. Modular multilevel converters for HVDC applications: review on converter cells and functionalities. *IEEE Trans Power Electron* 2015;30(1):18–36.
- [165] Kenzelmann S, Rufer A, Dujic D, Canales F, De Novaes YR. Isolated DC/DC structure based on modular multilevel converter. *IEEE Trans Power Electron* 2015;30(1):89–98.
- [166] Gowaid IA, Adam GP, Massoud AM, Ahmed S, Holliday D, Williams BW. Quasi two-level operation of modular multilevel converter for use in a high-power DC transformer with DC fault isolation capability. *IEEE Trans Power Electron* 2015;30(1):108–23.
- [167] Gowaid IA, Adam GP, Ahmed S, Holliday D, Williams BW. Analysis and design of modular multilevel converter with trapezoidal modulation for medium and high voltage DC-DC transformers. *IEEE Trans Power Electron* 2015;30(10):5439–57.
- [168] Shi Y, Li H. Isolated modular multilevel DC-DC converter with DC fault current control capability based on current-fed dual active bridge for MVDC battery energy storage application. *IEEE Trans Power Electron* 2017;1–17. <http://dx.doi.org/10.1109/TPEL.2017.2695575>. [early access article].
- [169] Chen Y, Zhao S, Li Z, Wei X, Kang Y. Modeling and control of the isolated DC–DC modular multilevel converter for electric ship medium voltage direct current power system. *IEEE J Emerg Sel Top Power Electron* 2017;5(1):124–39.
- [170] Jamshidi Far AA, Hajian M, Jovcic D, Audichya Y. High-power modular multilevel converter optimal design for DC/DC converter applications. *IET Power Electron* 2016;9(2):247–55.
- [171] Xing Z, Ruan X, You H, Yang X, Yao D, Yuan C. Soft-switching operation of isolated modular DC/DC converters for application in HVDC grids. *IEEE Trans Power Electron* 2016;31(4):2753–66.
- [172] Inoue S, Akagi H. A bidirectional isolated DC–DC converter as a core circuit of the next-generation medium-voltage power conversion system. *IEEE Trans Power Electron* 2007;22(2):535–42.
- [173] Cha H, Ding R, Tang Q, Peng FZ. Design and development of high-power DC–DC converter for metro vehicle system. *IEEE Trans Industr Appl* 2008;44(6):1795–804.
- [174] Fan H, Li H. High-frequency transformer isolated bidirectional DC–DC converter modules with high efficiency over wide load range for 20 kVA solid-state transformer. *IEEE Trans Power Electron* 2011;26(12):3599–608.
- [175] Agamy MS, Dong D, Garcés LJ, Zhang Y, Dame ME, Wu X, et al. A high power medium voltage resonant dual active bridge for MVDC ship power networks. *IEEE J Emerg Sel Top Power Electron* 2017;5(1):88–99.
- [176] Yang G, Xiao F, Fan X, Wang R, Liu J. Three-phase three-level phase-shifted PWM DC–DC converter for electric ship MVDC application. *IEEE J Emerg Sel Top Power Electron* 2017;5(1):162–70.
- [177] Taufiq J. Power electronics technologies for railway vehicles. *Proc. power conversion conference*. 2007. p. 1388–93.
- [178] Claessens M, Dujic D, Canales F, Steinke JK, Stefanutti P, Vetterli C. Traction transformation – a power-electronic traction transformer (PETT). *ABB Rev* 2012;1:11–7.
- [179] Zhao C, Dujic D, Mester A, Steinke JK, Weiss M, Lewdeni-Schmid S, et al. Power electronic traction transformer – medium voltage prototype. *IEEE Trans Industr Electron* 2014;61(7):3257–68.
- [180] Bernet S. Recent developments of high power converters for industry and traction applications. *IEEE Trans Power Electron* 2000;15(6):1102–17.
- [181] Lago J, Heldwein ML. Operation and control-oriented modeling of a power converter for current balancing and stability improvement of DC active distribution networks. *IEEE Trans Power Electron* 2011;26(3):877–85.
- [182] Giulivo D, Sulligoi G, Tassarolo A. Electric motors and drives for modern ship thruster propulsion: design and system integration issues. *Proc. electrical systems for aircraft, railway and ship propulsion (ESARS)*. 2010. p. 1–6.
- [183] Bosich D, Filippo M, Giulivo D, Sulligoi G, Tassarolo A. Thruster motor start-up transient in an all-electric cruise-liner: numerical simulation and experimental assessment. *Proc. electrical systems for aircraft, railway and ship propulsion*. 2012. p. 1–5.
- [184] Domaschk LN, Ouroua A, Hebner RE, Bowlin OE, Colson WB. Coordination of large pulsed loads on future electric ships. *IEEE Trans Magn* 2007;43(1):450–5.
- [185] Mohan N, Broach JT. Converters for supplying pulsed power loads. *IEEE Trans Industr Appl* 1979;A-15(1):85–91.
- [186] Balathandayuthapani S, Edrington CS, Henry S. Study on converter topologies for capacitive pulse forming network and energy storage units in electric ship. *Proc. electric ship technologies symposium*. 2011. p. 459–62.
- [187] Kim SH, Ehsani M, Kim CS. High-voltage power supply using series-connected full-

- bridge PWM converter for pulsed power applications. *IEEE Trans Dielectr Electr Insul* 2015;22(4):1937–44.
- [188] Cuzner RM, Venkataraman G. The status of DC micro-grid protection. *Proc. IEEE industry applications society annual meeting (IAS)*. 2008. p. 1–8.
- [189] Farhadi M, Mohammed OA. Protection of multi-terminal and distributed DC systems: design challenges and techniques. *Electr Power Syst Res* 2017;143:715–27.
- [190] Wang Y, Yu Z, He J, Chen S, Zeng R, Zhang B. Performance of shipboard medium-voltage DC system of various grounding modes under monopole ground fault. *IEEE Trans Industr Appl* 2015;51(6):5002–9.
- [191] Jovcic D, Wu B. Fast fault current interruption on high-power DC networks. *Proc. power and energy society general meeting*. 2010. p. 1–6.
- [192] Jovcic D, Ooi BT. Theoretical aspects of fault isolation on high-power direct current lines using resonant direct current/direct current converters. *IET Gener Transmiss Distrib* 2011;5(2):153–60.
- [193] Monadi M, Gavriluta C, Luna A, Candela JI, Rodriguez P. Centralized protection strategy for medium voltage DC microgrids. *IEEE Trans Power Deliv* 2017;32(1):430–40.
- [194] Tang L, Wu B, Yaramasu V, Chen W, Athab HS. Novel DC/DC choppers with circuit breaker functionality for HVDC transmission lines. *Electr Power Syst Res* 2014;116:106–16.
- [195] Kish GJ, Ranjram M, Lehn PW. A modular multilevel DC/DC converter with fault blocking capability for HVDC interconnects. *IEEE Trans Power Electron* 2015;30(1):148–62.
- [196] Cairoli P, Dougal RA, Lentijo K. Coordination between supply power converters and contactors for fault protection in multi-terminal MVDC distribution systems. *Proc. electric ship technologies symposium*. 2013. p. 493–9.
- [197] Cairoli P, Kondratiev I, Dougal RA. Coordinated control of the bus tie switches and power supply converters for fault protection in DC microgrids. *IEEE Trans Power Electron* 2013;28(4):2037–47.
- [198] Cuzner RM, Singh V. Future shipboard MVDC system protection requirements and solid-state protective device topological tradeoffs. *IEEE J Emerg Sel Top Power Electron* 2017;5(1):244–59.
- [199] Meyer C, Kowal M, De Doncker RW. Circuit breaker concepts for future high-power DC-applications. *Proc. IEEE industry applications society annual meeting*. vol. 2. 2005. p. 860–6.
- [200] Franck CM. HVDC circuit breakers: a review identifying future research needs. *IEEE Trans Power Deliv* 2011;26(2):998–1007.
- [201] Schmerda RF, Krstic S, Wellner EL, Bendre AR. IGCTs vs. IGBTs for circuit breakers in advanced ship electrical systems. *Proc. IEEE electric ship technology symposium*. 2009. p. 400–5.
- [202] Martinez-Velasco JA, Magnusson J. Parametric analysis of the hybrid HVDC circuit breaker. *Int J Electr Power Energy Syst* 2017;84:284–95.
- [203] Meyer JM, Rufer A. A DC hybrid circuit breaker with ultra-fast contact opening and integrated gate-commutated thyristors (IGCTs). *IEEE Trans Power Deliv* 2006;21(2):646–51.
- [204] Roodenburg B, Taffone A, Gilardi E, Tenconi SM, Evenblij BH, Kaanders MAM. Combined ZVS–ZCS topology for high-current direct current hybrid switches: design aspects and first measurements. *IET Electr Power Appl* 2007;1(2):183–92.
- [205] Krstic S, Wellner EL, Bendre AR, Semenov B. Circuit breaker technologies for advanced ship power systems. *Proc. IEEE electric ship technology symposium*. 2007. p. 201–8.
- [206] Kempkes M, Roth I, Gaudreau M. Solid-state circuit breakers for medium voltage DC power. *Proc. IEEE electric ship technology symposium*. 2011. p. 254–7.
- [207] Juvekar S, Compton B, Bhattacharya S. A fast acting DC solid state fault isolation device (FID) with Si and SiC devices for MVDC distribution system. *Proc. IEEE energy conversion congress and exposition (ECCE)*. 2012. p. 2005–10.
- [208] Corzine KA, Ashton RW. A new Z-source DC circuit breaker. *IEEE Trans Power Electron* 2012;27(6):2796–804.
- [209] Schmerda R, Cuzner R, Clark R, Nowak D, Bunzel S. Shipboard solid-state protection – overview and applications. *IEEE Electr Mag* 2013;1(1):32–9.
- [210] Song X, Peng C, Huang AQ. A medium-voltage hybrid DC circuit breaker, Part I: solid-state main breaker based on 15 kV SiC emitter turn-OFF thyristor. *IEEE J Emerg Sel Top Power Electron* 2017;5(1):278–88.
- [211] Peng C, Song X, Huang AQ, Husain I. A medium-voltage hybrid DC circuit breaker – Part II: ultrafast mechanical switch. *IEEE J Emerg Sel Top Power Electron* 2017;5(1):278–88.
- [212] Novello L, Baldo F, Ferro A, Maistrello A, Gaio E. Development and testing of a 10-kA hybrid mechanical–static DC circuit breaker. *IEEE Trans Appl Supercond* 2011;21(6):3621–7.
- [213] Sano K, Takasaki M. A surgeless solid-state DC circuit breaker for voltage-source-converter-based HVDC systems. *IEEE Trans Industr Appl* 2014;50(4):2690–9.
- [214] Hassanpoor A, Häfner J, Jacobson B. Technical assessment of load commutation switch in hybrid HVDC breaker. *IEEE Trans Power Electron* 2015;30(10):5393–400.
- [215] Effah FB, Watson AJ, Ji C, Amankwah E, Johnson CM, Davidson C, et al. Hybrid HVDC circuit breaker with self-powered gate drives. *IET Power Electron* 2016;9(2):228–36.
- [216] Maqsood A, Corzine KA. Integration of Z-Source breakers into zonal DC ship power system microgrids. *IEEE J Emerg Sel Top Power Electron* 2017;5(1):269–77.