

Embedding compact surfaces into the 3-dimensional Euclidean space with maximum symmetry

Dedicated to Professor Boju Jiang on the Occasion of His 80th Birthday

WANG Chao¹, WANG ShiCheng^{2,*}, ZHANG YiMu³ & ZIMMERMANN Bruno⁴

¹*Jonsvannsveien 87B, H0201, Trondheim 7050, Norway;*

²*School of Mathematical Sciences, Peking University, Beijing 100871, China;*

³*Mathematics School, Jilin University, Changchun 130012, China;*

⁴*Dipartimento di Matematica e Geoscienze, Università degli Studi di Trieste, Trieste 34100, Italy*

Email: chao-wang.1987@126.com, wangsc@math.pku.edu.cn, zym534685421@126.com, zimmer@units.it

Accepted March 31, 2017

Abstract The symmetries of surfaces which can be embedded into the symmetries of the 3-dimensional Euclidean space \mathbb{R}^3 are easier to feel by human's intuition. We give the maximum order of finite group actions on (\mathbb{R}^3, Σ) among all possible embedded closed/bordered surfaces with given geometric/algebraic genus greater than 1 in \mathbb{R}^3 . We also identify the topological types of the bordered surfaces realizing the maximum order, and find simple representative embeddings for such surfaces.

Keywords finite group action, extendable action, symmetry of surface, maximum order

MSC(2010) 57M60, 57S25

1 Introduction

The maximum orders of finite group actions on surfaces have been studied for a long time, and a rather recent topic is to study the maximum orders of those finite group actions on closed surfaces which can extend over a given compact 3-manifold. Let Σ_g denote the closed orientable surface of (geometric) genus g . For each compact surface Σ , let $\alpha(\Sigma)$ denote its *algebraic genus*, defined as the rank of the fundamental group $\pi_1(\Sigma)$. In the following, we discuss some sample results about these maximum order problems:

(1) Maximum orders of finite group actions on surfaces: (i) A classical result of Hurwitz states that the maximum order of orientation-preserving finite group actions on Σ_g with $g > 1$ is at most $84(g - 1)$ (see [5] in 1893). (ii) The maximum order of finite cyclic group actions on Σ_g with $g > 1$ is $4g + 4$ for even g and $4g + 2$ for odd g (see [9] in 1935). (iii) The maximum order of finite group actions on bordered surfaces of algebraic genus $\alpha > 1$ is at most $12(\alpha - 1)$ (see [7] in 1975). In (i) and (iii), to determine those maximum orders for concrete genera is still a hard question in general, and there are numerous interesting partial results.

* Corresponding author

(2) Maximum orders of finite group actions on surfaces which can extend over a given 3-manifold M :
(i) The maximum order of finite group actions on Σ_g with $g > 1$ is at most $12(g - 1)$ when M is a handlebody and $\Sigma_g = \partial M$ (see [17] in 1979). (ii) Much more recently the maximum order of extendable finite group actions on Σ_g is determined when M is the 3-sphere S^3 , for cyclic group (see [13] for the orientation-preserving case and [15] for the general case); for general finite groups, see [14] for the orientation-preserving case and [11] for the general case. (iii) Some progress has been made when M is the 3-torus T^3 (see [12] for the cyclic case and [1] for the general case). In (i) and (iii), to determine those maximum orders for concrete genera is still not solved.

Surfaces belong to the most familiar topological subjects mostly because they can be seen staying in the 3-dimensional Euclidean space \mathbb{R}^3 in various manners. The symmetries of surfaces which can be embedded into the symmetries of \mathbb{R}^3 are easier to feel by intuition. Hence, it will be more natural to wonder the maximum orders of finite group actions on surfaces which extend over the 3-dimensional Euclidean space \mathbb{R}^3 . In this paper, we study this maximum order problem for all compact (closed/bordered) surfaces with given (geometric/algebraic) genera.

To state our results, we need some notions and definitions. We always assume that the manifolds, embeddings and group actions are smooth, and the group actions on \mathbb{R}^3 are faithful. Let $O(3)$ denote the isometry group of the unit sphere in the 3-dimensional Euclidean space \mathbb{R}^3 , and let $SO(3)$ denote the orientation-preserving isometry group of the unit sphere in \mathbb{R}^3 . It is known that any finite group G acting on \mathbb{R}^3 can be conjugated into $O(3)$, and especially it can be conjugated into $SO(3)$ if the G action is orientation-preserving (see [8] and [6]).

Definition 1.1. Let $e : \Sigma \hookrightarrow \mathbb{R}^3$ be an embedding of a compact surface Σ into \mathbb{R}^3 . If a group G acts on Σ and \mathbb{R}^3 such that $h \circ e = e \circ h$ for each $h \in G$ and the G -action on \mathbb{R}^3 can be conjugated into $O(3)$, then we call such a group action on Σ *extendable* over \mathbb{R}^3 with respect to e .

For simplicity, we will say “ G acts on the pair (\mathbb{R}^3, Σ) ” in the sense of this definition.

Remark 1.2. An orthogonal action on \mathbb{R}^3 fixes 0 and extends orthogonally to \mathbb{R}^4 acting trivially on the new coordinate, so it fixes pointwise a line in \mathbb{R}^4 through 0 and restricts to an orthogonal action on $S^3 \subset \mathbb{R}^4$ with a fixed point. Vice versa, an orthogonal action on S^3 with a fixed point P acts orthogonally on \mathbb{R}^4 , fixes 0 and P and pointwise the line in \mathbb{R}^4 through 0 and P , and hence restricts to an orthogonal action on the \mathbb{R}^3 orthogonal to this line. So the actions on (S^3, Σ) with at least one fixed point are the same as the actions on (\mathbb{R}^3, Σ) .

Let $\Sigma_{g,b}$ denote the orientable compact surface with genus g and b boundary components, and for $g > 0$ let $\Sigma_{g,b}^-$ denote the non-orientable compact surface with genus g and b boundary components. Note that $\Sigma_{g,0}$ is the same as Σ_g , and $\Sigma_{g,0}^-$ is the connected sum of g real projective planes. It is well known that each compact surface is either $\Sigma_{g,b}$ or $\Sigma_{g,b}^-$, the surfaces with $b = 0$ give all closed surfaces, the surfaces with $b \neq 0$ give all compact bordered surfaces, and only $\Sigma_{g,0}^-$ cannot be embedded into \mathbb{R}^3 . Also note that $\alpha(\Sigma_{g,0}) = 2g$.

Definition 1.3. For a fixed $g > 1$, let E_g be the maximum order of all extendable finite group actions on Σ_g for all embeddings $\Sigma_g \hookrightarrow \mathbb{R}^3$; let CE_g be the maximum order of all extendable cyclic group actions on Σ_g for all embeddings $\Sigma_g \hookrightarrow \mathbb{R}^3$; if we require that the actions are orientation-preserving on \mathbb{R}^3 (i.e., the group action can be conjugated into $SO(3)$), then the maximum orders we get will be denoted by E_g^o and CE_g^o , respectively.

For a fixed $\alpha > 1$, let EA_α be the maximum order of all extendable finite group actions on Σ for all embeddings $\Sigma \hookrightarrow \mathbb{R}^3$ among all bordered surfaces with $\alpha(\Sigma) = \alpha$; let CEA_α be the maximum order of all extendable cyclic group actions on Σ for all embeddings $\Sigma \hookrightarrow \mathbb{R}^3$ among all bordered surfaces with $\alpha(\Sigma) = \alpha$; if we require that the actions are orientation-preserving on \mathbb{R}^3 , then the maximum orders we get will be denoted by EA_α^o and CEA_α^o , respectively.

Note that in the above definition if $g \leq 1$ or $\alpha \leq 1$, then the maximum order will be infinite (consider sphere, torus, disk and annulus). Our first results are about the closed surfaces.

Theorem 1.4. For each $g > 1$,

Table 1 Orientation-preserving extendable group actions on closed surfaces

g	E_g^o
3	12
5, 7	24
11, 19, 21	60
others	$2g + 2$

Table 2 Orientation-preserving extendable group actions on bordered surfaces

α	EA_α^o	Σ
3	12	$\Sigma_{0,4}, \Sigma_{1,3}^-$
5	24	$\Sigma_{0,6}, \Sigma_{1,4}$
7	24	$\Sigma_{0,8}, \Sigma_{4,4}^-$
11	60	$\Sigma_{0,12}, \Sigma_{6,6}^-$
19	60	$\Sigma_{0,20}, \Sigma_{4,12}, \Sigma_{10,10}^-, \Sigma_{14,6}^-$
21	60	$\Sigma_{5,12}$
29	60	$\Sigma_{0,30}, \Sigma_{5,20}, \Sigma_{9,12}, \Sigma_{14,2}$
others, α even	$2\alpha + 2$	$\Sigma_{0,\alpha+1}, \Sigma_{\alpha/2,1}$
others, α odd	$2\alpha + 2$	$\Sigma_{0,\alpha+1}, \Sigma_{(\alpha-1)/2,2}$

Table 3 Extendable group actions on bordered surfaces

α	EA_α	Σ
3	24	$\Sigma_{0,4}$
5	48	$\Sigma_{0,6}$
7	48	$\Sigma_{0,8}$
11	120	$\Sigma_{0,12}$
19	120	$\Sigma_{0,20}$
others	$4\alpha + 4$	$\Sigma_{0,\alpha+1}$

- (1) CE_g^o is $g + 1$;
- (2) CE_g is $2g + 2$ for even g and $2g$ for odd g .

Theorem 1.5. For each $g > 1$,

- (1) E_g^o is given in Table 1;
- (2) $E_g = 2E_g^o$ when $g \neq 21$, and $E_{21} = 88$.

Remark 1.6. The embedded surfaces realizing CE_g^o and CE_g can be unknotted as well as knotted (where, viewing S^3 as the one-point compactification of \mathbb{R}^3 , a surface is unknotted if it bounds handlebodies on both sides). This is also true for E_g^o with $g \neq 21$. For E_{21}^o the surfaces must be knotted. On the other hand, the embedded surfaces realizing E_g must be unknotted. At this point, it would be worth comparing with those results in [11, 14].

Note that when $b \neq 0$, $\alpha(\Sigma_{g,b}) = 2g - 1 + b$ and $\alpha(\Sigma_{g,b}^-) = g - 1 + b$. Therefore, there are many bordered surfaces having algebraic genus α . For the bordered surfaces, we have the following results.

Theorem 1.7. For each $\alpha > 1$,

- (1) CEA_α^o is $\alpha + 1$, and the surfaces realizing CEA_α^o are $\Sigma_{0,\alpha+1}$ and $\Sigma_{\alpha/2,1}$ when α is even, and are $\Sigma_{0,\alpha+1}$ and $\Sigma_{(\alpha-1)/2,2}$ when α is odd;
- (2) CEA_α is $2\alpha + 2$ for even α and 2α for odd α , and the surface realizing CEA_α is $\Sigma_{0,\alpha+1}$ in both cases.

Theorem 1.8. For each $\alpha > 1$,

- (1) EA_α^o and the surfaces realizing EA_α^o are listed in Table 2;
- (2) EA_α and the surfaces realizing EA_α are listed in Table 3.

Remark 1.9. In the above theorems, all the group actions realizing the maximum orders must be faithful on the compact surfaces, except for the case of CEA_α with odd α . In this case, the group action realizing CEA_α must be non-faithful on $\Sigma_{0,\alpha+1}$. If we require that the actions on surfaces are faithful, then CEA_α is $\alpha + 1$ for odd α (see Proposition 4.4). There can be various different surfaces realizing this maximum order.

Remark 1.10. Extending group actions on bordered surfaces seems to be addressed for the first time in the present note. A connection to knot theory is below: the group action on (\mathbb{R}^3, Σ) is also a group action on $(\mathbb{R}^3, \Sigma, \partial\Sigma)$. If we view $\partial\Sigma$ as a link in \mathbb{R}^3 and Σ as its Seifert surface, then Theorem 1.8(1) provides many interesting examples of $(\mathbb{R}^3, \text{Seifert surface, link})$ with large symmetries. See Section 4 for intuitive pictures.

Remark 1.11. We note the paper [3] of the similar interest but quite different content, which addresses when bordered surfaces Σ can be embedded into \mathbb{R}^3 so that those surface homeomorphisms permuting boundary components of Σ can extend over \mathbb{R}^3 .

Finally we give a brief description of the organization of the paper.

In Section 2, we list some facts about orbifolds and their coverings, as well as automorphisms of small permutation groups, which will be used in the proofs.

In Section 3, we prove Theorems 1.4 and 1.5. The upper bound is obtained by applying the Riemann-Hurwitz formula and some preliminary, but somewhat tricky, arguments on 2- and 3-dimensional orbifolds; the equivariant Dehn's lemma is not involved.

In Section 4, we prove Theorems 1.7 and 1.8. The upper bounds in Theorems 1.4 and 1.5 will be used to give the upper bounds in Theorems 1.7 and 1.8. The most complicated part of this paper is to identify the topological types of those surfaces realizing the upper bounds and find simple representative embeddings for such bordered surfaces.

The examples in Sections 3 and 4 reaching the upper bound are visible as expected, however several examples, including Example 3.2(3) and those in Figures 13 and 14, should be beyond the expectation of most people (including some of the authors) before they were found.

In Section 5, we give similar results for graphs in \mathbb{R}^3 .

2 Preliminaries

In this section, we list some facts which will be used in the later proofs.

For the orbifold theory, see [2, 4, 10]. We give a brief description here. All of the n -orbifolds that we considered have the form M/H . Here, M is an n -manifold and H is a finite group acting faithfully on M . For each point $x \in M$, denote its stable subgroup by $\text{St}(x)$, its image in M/H by x' . If the order $|\text{St}(x)| > 1$, x' is called a *singular point* with *index* $|\text{St}(x)|$, otherwise it is called a *regular point*. If we forget the singular set, then we get the topological *underlying space* $|M/H|$ of the orbifold M/H .

We make a convention that in the orbifold setting, for $X = \Sigma/G$, we define $\partial X = \partial\Sigma/G$, the image of $\partial\Sigma$ under the group action (call it the real boundary of X).

A simple picture we should keep in mind is the following: suppose that G acts on (\mathbb{R}^3, Σ) and let

$$\Gamma_G = \{x \in \mathbb{R}^3 \mid \exists g \in G, g \neq \text{id, s.t. } gx = x\}.$$

Then Γ_G/G is the singular set of the 3-orbifold \mathbb{R}^3/G , and Σ/G is a 2-orbifold with singular set $\Sigma/G \cap \Gamma_G/G$.

The covering spaces and the fundamental group of an orbifold can also be defined. Moreover, there is a one-to-one correspondence between the orbifold covering spaces and the conjugacy classes of subgroups of the fundamental group, and regular covering spaces correspond to normal subgroups. In the following, automorphisms, covering spaces and fundamental groups always refer to the orbifold setting.

Note that an involution (periodical map of order 2) on \mathbb{R}^3 is conjugate to either a reflection (about a plane), or a π -rotation (about a line), or an antipodal map (about a point).

Theorem 2.1 (Riemann-Hurwitz formula). *Suppose that $\Sigma_g \rightarrow \Sigma_{g'}$ is a regular branched covering with transformation group G . Let a_1, a_2, \dots, a_k be the branched points in $\Sigma_{g'}$ having indices q_1, q_2, \dots, q_k . Then*

$$2 - 2g = |G| \left(2 - 2g' - \sum_{i=1}^k \left(1 - \frac{1}{q_i} \right) \right).$$

We say that a group G acts on the pair (\mathbb{R}^3, Σ) orientation-reversingly if there exists some $g \in G$ such that g acts on \mathbb{R}^3 orientation-reversingly.

Lemma 2.2. *Suppose that G acts on (\mathbb{R}^3, Σ_g) orientation-reversingly and let*

$$G^o = \{g \in G \mid g \text{ acts orientation-preservingly on } (\mathbb{R}^3, \Sigma_g)\}.$$

Then G^o is an index 2 subgroup in G .

Since every fixed point free involution on compact manifold X gives a quotient manifold X/\mathbb{Z}_2 , with Euler characteristic $\chi(X/\mathbb{Z}_2) = \frac{1}{2}\chi(X)$, we have the following lemma.

Lemma 2.3. *There is no fixed point free involution on a compact manifold X with odd Euler characteristic $\chi(X)$.*

Lemma 2.4. *Suppose that the cyclic group $\mathbb{Z}_{2n} \subset O(3)$ acts on \mathbb{R}^3 orientation-reversingly. Then its induced \mathbb{Z}_2 -action on $|\mathbb{R}^3/\mathbb{Z}_n| \cong \mathbb{R}^3$ conjugates to a reflection or an antipodal map, whose fixed point set intersects the singular line of $\mathbb{R}^3/\mathbb{Z}_n$ transversely at one point.*

Lemma 2.5. *Suppose that G acts on a compact surface Σ such that each singular point in the orbifold $X = \Sigma/G$ is isolated and the underlying space $|X|$ is orientable. Then Σ is orientable.*

Proof. A compatible local orientation system of $|X|$ can be lifted to a compatible local orientation system of Σ . Hence, it gives an orientation of Σ . \square

Lemma 2.6. *Suppose that G acts on an orientable compact surface Σ such that the orbifold $X = \Sigma/G$ contains non-isolated singular points or the underlying space $|X|$ is non-orientable. Then G has an index 2 subgroup.*

Proof. There must be an element of G reversing the orientation of Σ . Then the orientation-preserving elements of G form an index 2 subgroup. \square

Lemma 2.7. *Suppose that G acts on \mathbb{R}^3 and X is a suborbifold of \mathbb{R}^3/G such that $|X|$ is connected. Let $i : X \hookrightarrow \mathbb{R}^3/G$ be the inclusion map. Then the preimage of X in \mathbb{R}^3 has $[\pi_1(\mathbb{R}^3/G) : i_*(\pi_1(X))]$ connected components.*

Proof. Consider the covering space of \mathbb{R}^3/G corresponding to the subgroup $H = i_*(\pi_1(X))$. It is \mathbb{R}^3/H . Then the inclusion map i can be lifted to a map $\tilde{i} : X \rightarrow \mathbb{R}^3/H$. Since i is an embedding, \tilde{i} is also an embedding, i.e.,

$$\begin{array}{ccc} & & \mathbb{R}^3 \\ & & \downarrow \\ & & \mathbb{R}^3/H \\ \tilde{i} \nearrow & & \downarrow \\ X & \xrightarrow{i} & \mathbb{R}^3/G. \end{array}$$

Note that the lift \tilde{i} has totally $[G : H]$ different choices, and different choices correspond to disjoint images in \mathbb{R}^3/H . For each given \tilde{i} , the induced homomorphism $\tilde{i}_* : \pi_1(X) \rightarrow \pi_1(\mathbb{R}^3/H)$ is surjective. Then by [14, Lemma 2.10], the preimage of $\tilde{i}(X)$ in \mathbb{R}^3 is connected. Hence, the preimage of X in \mathbb{R}^3 has $[G : H] = [\pi_1(\mathbb{R}^3/G) : i_*(\pi_1(X))]$ connected components. \square

Let S_n denote the permutation group on the numbers $\{1, 2, 3, \dots, n\}$, and let A_n denote its alternating subgroup. Let $\text{Aut}(G)$ denote the automorphism group of a group G . For an element $x \in S_n$, let $\text{ord}(x)$ denote its order. The following algebraic facts will be used to identify the compact surfaces realizing the maximum orders.

Lemma 2.8. (1) If $\{x, y\}$ generates A_4 with $\text{ord}(x) = 2$ and $\text{ord}(y) = 3$, then there exists $\sigma \in \text{Aut}(A_4)$ such that $\{\sigma(x), \sigma(y)\} = \{(12)(34), (123)\}$.

(2) If $\{x, y\}$ generates S_4 with $\text{ord}(x) = 2$ and $\text{ord}(y) = 3$, then there exists $\sigma \in \text{Aut}(S_4)$ such that $\{\sigma(x), \sigma(y)\} = \{(12), (134)\}$.

(3) If $\{x, y\}$ generates S_4 with $\text{ord}(x) = 2$ and $\text{ord}(y) = 4$, then there exists $\sigma \in \text{Aut}(S_4)$ such that $\{\sigma(x), \sigma(y)\} = \{(12), (1234)\}$.

(4) If $\{x, y\}$ generates A_5 with $\text{ord}(x) = 2$ and $\text{ord}(y) = 3$, then there exists $\sigma \in \text{Aut}(A_5)$ such that $\{\sigma(x), \sigma(y)\} = \{(12)(34), (135)\}$.

(5) If $\{x, y\}$ generates A_5 with $\text{ord}(x) = 2$ and $\text{ord}(y) = 5$, then there exists $\sigma \in \text{Aut}(A_5)$ such that one of the following two cases holds:

$$\{\sigma(x), \sigma(y)\} = \{(12)(34), (12345)\}, \quad \{\sigma(x), \sigma(y)\} = \{(13)(24), (12345)\}.$$

(6) If $\{x, y\}$ generates A_5 with $\text{ord}(x) = 3$ and $\text{ord}(y) = 3$, then there exists $\sigma \in \text{Aut}(A_5)$ such that $\{\sigma(x), \sigma(y)\} = \{(123), (145)\}$.

(7) If $\{x, y\}$ generates A_5 with $\text{ord}(x) = 3$ and $\text{ord}(y) = 5$, then there exists $\sigma \in \text{Aut}(A_5)$ such that one of the following four cases holds:

$$\begin{aligned} \{\sigma(x), \sigma(y)\} &= \{(123), (12345)\}, & \{\sigma(x), \sigma(y)\} &= \{(132), (12345)\}, \\ \{\sigma(x), \sigma(y)\} &= \{(124), (12345)\}, & \{\sigma(x), \sigma(y)\} &= \{(142), (12345)\}. \end{aligned}$$

Proof. Since A_4 , S_4 and A_5 have small orders, all these facts can be checked by an elementary enumeration. We prove (5) as an example.

Note that x must have the form $(ab)(cd)$ with $a, b, c, d \in \{1, 2, 3, 4, 5\}$ and y must be a rotation of order 5, so up to an automorphism we can assume that y is (12345) and $\{a, b, c, d\} = \{1, 2, 3, 4\}$. Then there are three cases: x is $(12)(34)$ or $(13)(24)$ or $(14)(23)$. However, $(14)(23)$ and (12345) do not generate A_5 , since they generate an order 10 subgroup of A_5 which is a dihedral group. So we have the statement as in the lemma. \square

3 Closed surfaces in \mathbb{R}^3

In this section, we first construct some extendable actions which will be used to realize CE_g^o , CE_g , E_g^o and E_g . The symmetries are those people can feel in their daily life. Then we give the proofs of Theorems 1.4 and 1.5.

In the following examples, we will give a finite graph $\Gamma \subset \mathbb{R}^3$ and a group action on (\mathbb{R}^3, Γ) . The action will be orthogonal and keep Γ invariant as a set. Then there exists a regular neighborhood of Γ , denoted by $N(\Gamma)$, such that (1) $\partial N(\Gamma)$ is a smoothly embedded closed surface in \mathbb{R}^3 ; (2) the action keeps $\partial N(\Gamma)$ invariant; (3) the genus of $\partial N(\Gamma)$ is the same as the genus of Γ , defined as $g(\Gamma) = 1 - \chi(\Gamma)$, where $\chi(\Gamma)$ is the Euler characteristic of Γ . Then we get extendable actions on $\partial N(\Gamma)$.

Example 3.1 (General case). (1) For each $g > 1$, let $\Gamma_g^1 \subset \mathbb{R}^3$ be a graph with 2 vertices and $g + 1$ edges as Figure 1(a) (for $g = 2$). It has genus g . Then note that

(i) there is a $2\pi/(g+1)$ -rotation τ_{g+1} , which generates a cyclic group of order $g+1$ acting on $(\mathbb{R}^3, \Gamma_g^1)$;
(ii) there is an orientation-preserving dihedral group D_{g+1} action on $(\mathbb{R}^3, \Gamma_g^1)$, where D_{g+1} is generated by τ_{g+1} and a π -rotation ρ around the axis, which intersects an edge of Γ_g^1 and the rotation axis of τ_{g+1} in the plane;

(iii) when g is even, the composition of the reflection r about the plane and the rotation τ_{g+1} generates an order $2g+2$ cyclic group action on $(\mathbb{R}^3, \Gamma_g^1)$;

(iv) τ_{g+1} , ρ and r generate a finite group of order $4g+4$ acting on $(\mathbb{R}^3, \Gamma_g^1)$.

(2) For odd g , let $\Gamma_g^2 \subset \mathbb{R}^3$ be a graph with 2 vertices and $g+1$ edges as Figure 1(b) (for $g = 3$). It has genus g . Then the composition of the reflection r about the plane and a $2\pi/g$ -rotation generates an order $2g$ cyclic group action on $(\mathbb{R}^3, \Gamma_g^2)$.

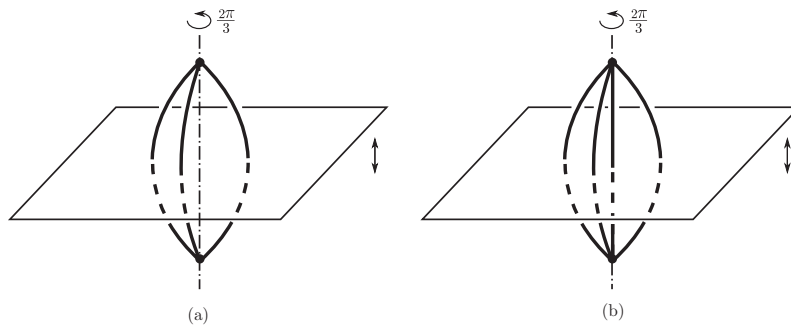

Figure 1 Symmetric dipole graphs

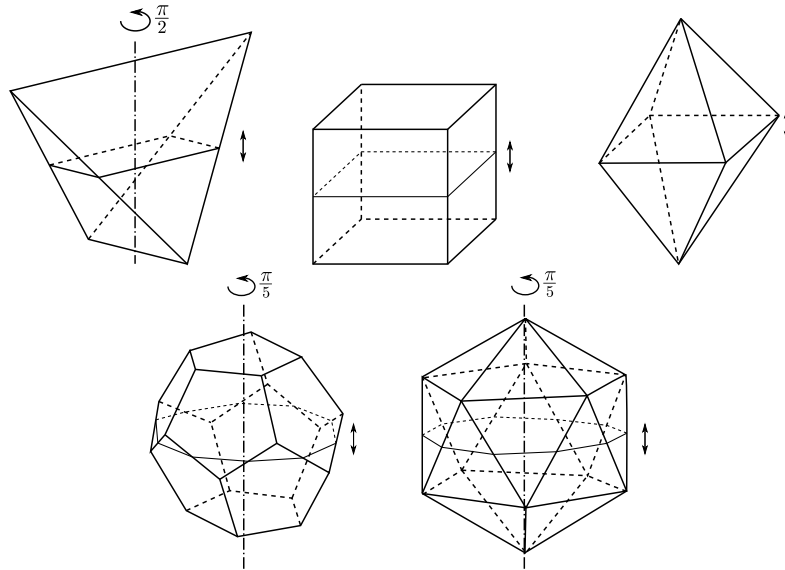

Figure 2 Regular polyhedra

Example 3.2 (Special case). Let T , C , O , D and I be the regular tetrahedron, cube, octahedron, dodecahedron, icosahedron. Their 1-skeletons $T^{(1)}$, $C^{(1)}$, $O^{(1)}$, $D^{(1)}$ and $I^{(1)}$ are graphs in \mathbb{R}^3 with genus 3, 5, 7, 11, 19, respectively (see Figure 2).

(1) The orientation-preserving isometry groups of the regular polyhedra keep the graphs invariant. The group is A_4 of order 12 for T , is S_4 of order 24 for C and O , and is A_5 of order 60 for D and I .

(2) The isometry groups of the regular polyhedra keep the graphs invariant. These groups are obtained by adding orientation-reversing elements into the groups in (1), and have orders 24, 48, 48, 120 and 120, respectively. For T , the adding element can be the composition of a reflection and a $\pi/2$ -rotation; for C and O , the adding element can be a reflection; for D and I , the adding element can be the composition of a reflection and a $\pi/5$ -rotation. Actually, all these groups are generated by reflections.

(3) Consider an enlarged regular dodecahedron D' with the same center as D . Let v be a vertex of D and let v' be the vertex of D' corresponding to v . Let w be a vertex of D' adjacent to v' . We can choose an arc connecting v and w such that its images under the orientation-preserving isometry group of D only meet at vertices of D and D' . Then the union of these image arcs is a connected graph with 40 vertices and 60 edges, therefore has genus 21, and the orientation-preserving isometry group of D keeps it invariant.

Proposition 3.3. Suppose that the cyclic group \mathbb{Z}_n acts on (\mathbb{R}^3, Σ_g) with $g > 1$ orientation-preservingly. Then one of the following holds:

- (i) $n = g + 1$, and Σ_g/\mathbb{Z}_n is a sphere with 4 singular points of index n ;
- (ii) $n = g$, and Σ_g/\mathbb{Z}_n is a torus with 2 singular points of index n ;
- (iii) $n = g - 1$, and Σ_g/\mathbb{Z}_n is a closed surface of genus 2;

(iv) $n \leq g/2 + 1$.

Proof. Since the \mathbb{Z}_n -action can be conjugated into $SO(3)$, it is a rotation of order n around a line. Then the 3-orbifold $\mathcal{O} = \mathbb{R}^3/\mathbb{Z}_n$ has the underlying space \mathbb{R}^3 and the singular set a line with index n . The 2-orbifold $X = \Sigma_g/\mathbb{Z}_n$, with underlying space a closed surface, must be separating in \mathcal{O} . Hence, X has an even number of singular points. Suppose that X has $2k'$ singular points and $|X|$ has genus g' . Then by the Riemann-Hurwitz formula we have $2 - 2g = n(2 - 2g' - 2k'(1 - \frac{1}{n})) = n(2 - 2g' - 2k') + 2k'$. Since $g > 1$ and $2 - 2g' - 2k' < 0$, we have $g' + k' - 1 \geq 1$ and $n = \frac{g+k'-1}{g'+k'-1} = \frac{g}{g'+k'-1} + \frac{k'-1}{g'+k'-1}$.

If $g' + k' - 1 = 1$, then $g' + k' = 2$ and $n = g + k' - 1$. When $k' = 2$, $n = g + 1$ and $g' = 0$; when $k' = 1$, $n = g$ and $g' = 1$; when $k' = 0$, $n = g - 1$ and $g' = 2$. If $g' + k' - 1 \geq 2$, then $n \leq g/2 + 1$. \square

Proposition 3.4. *When $g > 1$ is odd, \mathbb{Z}_{2g+2} and \mathbb{Z}_{2g-2} cannot act on (\mathbb{R}^3, Σ_g) orientation-reversingly.*

Proof. Suppose that \mathbb{Z}_{2g+2} acts on (\mathbb{R}^3, Σ_g) orientation-reversingly. Let t be a generator of \mathbb{Z}_{2g+2} . Then t^2 generates \mathbb{Z}_{g+1} . Let $X = \Sigma_g/\mathbb{Z}_{g+1}$. Then by Proposition 3.3, X is a sphere with 4 singular points, and it bounds a 3-orbifold \mathcal{O}_1 in $\mathbb{R}^3/\mathbb{Z}_{g+1}$ such that $|\mathcal{O}_1|$ is a 3-ball and the singular set of \mathcal{O}_1 consists of two arcs. By Lemma 2.4, t induces an orientation-reversing \mathbb{Z}_2 -action on \mathcal{O}_1 , which cannot have a fixed point in each singular arc of \mathcal{O}_1 . Then it has no singular fixed point. Since $|\mathcal{O}_1|$ has Euler characteristic 1, by Lemma 2.3 there exists a regular fixed point $x \in \mathcal{O}_1$. Let x' be a preimage of x in \mathbb{R}^3 . Then the stable subgroup $\text{St}(x') \subset \mathbb{Z}_{2g+2}$ is isomorphic to \mathbb{Z}_2 and its generator t^{g+1} is orientation-reversing. This leads to a contradiction since g is odd. For \mathbb{Z}_{2g-2} , by Proposition 3.3, the corresponding X is a closed surface of genus 2, and it bounds a 3-manifold M in $\mathbb{R}^3/\mathbb{Z}_{g-1}$ such that M has Euler characteristic -1 . Then the induced \mathbb{Z}_2 -action has a fixed point $x \in M$ by Lemma 2.3, and we can get a contradiction as above since g is odd. \square

Proof of Theorem 1.4. (1) By Example 3.1(1)(i) \mathbb{Z}_{g+1} acts on $(\mathbb{R}^3, \partial N(\Gamma_g^1))$ orientation-preservingly. Then by Proposition 3.3, $\text{CE}_g^o = g + 1$.

(2) By Examples 3.1(1)(iii) and 3.1(1)(ii), when g is even, \mathbb{Z}_{2g+2} acts on $(\mathbb{R}^3, \partial N(\Gamma_g^1))$ orientation-reversingly; when g is odd, \mathbb{Z}_{2g} acts on $(\mathbb{R}^3, \partial N(\Gamma_g^2))$ orientation-reversingly. Then by Theorem 1.4(1), the extendable action reaching CE_g must be orientation-reversing. Hence by Lemma 2.2 and Proposition 3.4, CE_g is $2g + 2$ for even g and $2g$ for odd g . \square

Proof of Theorem 1.5. (1) By Examples 3.1(1)(ii) and 3.2(1), we only need to show that if G orientation-preservingly acts on (\mathbb{R}^3, Σ_g) , then $|G|$ is not bigger than the value given in Theorem 1.5. Since the G -action can be conjugated into $SO(3)$, by Theorem 1.4(1) we can assume that G is one of D_n , A_4 , S_4 and A_5 . Here, D_n is the dihedral group of order $2n$. The singular set of the corresponding orbifold $\mathcal{O} = \mathbb{R}^3/G$ is shown in Figure 3. The underlying space of \mathcal{O} is always \mathbb{R}^3 , and the indices are the index numbers of the branch lines.

The 2-orbifold $X = \Sigma_g/G$ must be separating in \mathcal{O} , and hence X bounds a 3-orbifold \mathcal{O}_1 in \mathcal{O} such that $|\mathcal{O}_1|$ is compact. Suppose that X has k singular points and $|X|$ has genus g' . Then by the Riemann-Hurwitz formula we have $2 - 2g = |G|(2 - 2g' - \sum_{i=1}^k (1 - \frac{1}{q_i}))$. We can assume that $|G| > 2g - 2$. Note that $q_i > 1$ for each i , then

$$2g' + \frac{k}{2} \leq 2g' + \sum_{i=1}^k \left(1 - \frac{1}{q_i}\right) = 2 + \frac{2g - 2}{|G|} < 3.$$

Hence $4g' + k \leq 5$. If $g' = 1$, then $k \leq 1$. Since X cannot intersect the singular set of \mathcal{O} only once, we have $k = 0$. Since $g > 1$, this contradicts the Riemann-Hurwitz formula. Hence $g' = 0$, $k \leq 5$ and $|\mathcal{O}_1|$ is a 3-ball.

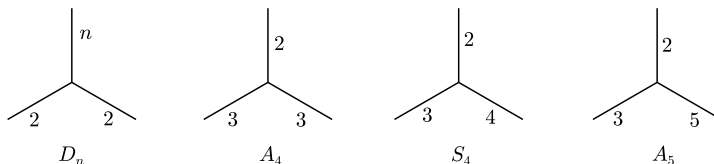

Figure 3 Singular set of the orbifolds \mathbb{R}^3/G

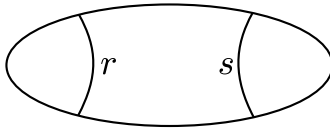

Figure 4 3-ball with two singular arcs

If \mathcal{O}_1 contains the vertex of the singular set of \mathcal{O} , then each half line of the singular set of \mathcal{O} must intersect X odd times. Choose an intersection in each half line and assume that they have indices q_1 , q_2 and q_3 . Then for each case of D_n , A_4 , S_4 and A_5 we have $\sum_{i=1}^3(1 - \frac{1}{q_i}) = 2(1 - \frac{1}{|G|})$. (One can check this directly, for example, for A_4 , $\{q_1, q_2, q_3\} = \{2, 3, 3\}$ and $|A_4| = 12$.) The Riemann-Hurwitz formula now becomes $2g = |G| \sum_{i=4}^k(1 - \frac{1}{q_i})$. Hence $k = 5$. Then since $q_i > 1$ for each i , we have $|G| \leq 2g$.

If \mathcal{O}_1 does not contain the vertex of the singular set of \mathcal{O} , then each half line of the singular set of \mathcal{O} must intersect X even times. Then we can assume that $k = 2k'$ and $q_i = q_{i+k'}$ for $1 \leq i \leq k'$. The Riemann-Hurwitz formula now becomes $2 - 2g = |G|(2 - 2 \sum_{i=1}^{k'}(1 - \frac{1}{q_i}))$. Since $g > 1$ and $q_i > 1$ for each i , we have $k' = 2$ and $k = 4$. Hence X is a sphere with 4 singular points, and \mathcal{O}_1 is as Figure 4. Here, r and s are the indices of the singular arcs in \mathcal{O}_1 . We can assume that $1 < r \leq s$. The Riemann-Hurwitz formula can be rewritten as $g - 1 = |G|(1 - \frac{1}{r} - \frac{1}{s})$. Since we assume that $|G| > 2g - 2$, we have $\frac{1}{r} + \frac{1}{s} > \frac{1}{2}$. If $G = D_n$, then G contains \mathbb{Z}_n as an index 2 subgroup. By Theorem 1.4(1), $n \leq g + 1$. Hence $|G| \leq 2g + 2$. The equality holds when $n = g + 1$ and $(r, s) = (2, n)$. If $G = A_4$, then $|G| = 12$ and (r, s) is one of $(2, 3)$ and $(3, 3)$. Hence g is 3 or 5. If $G = S_4$, then $|G| = 24$ and (r, s) is one of $(2, 3)$, $(2, 4)$, $(3, 3)$ and $(3, 4)$. Hence g is one of 5, 7, 9 and 11. If $G = A_5$, then $|G| = 60$ and (r, s) is one of $(2, 3)$, $(2, 5)$, $(3, 3)$ and $(3, 5)$. Hence g is one of 11, 19, 21 and 29. Then we get the results except the case of $g = 9$.

If $G = S_4$ and $(r, s) = (3, 3)$, then $\pi_1(X)$ is generated by elements of order 3. Hence its image in $\pi_1(\mathcal{O}) \cong G$ is contained in A_4 . By Lemma 2.7 the preimage of X in \mathbb{R}^3 is not connected. However by our definition the preimage of X is Σ_g which is connected. The contradiction means that the above case of $g = 9$ does not happen.

(2) By Examples 3.1(1)(iv), 3.2(2), Theorem 1.5(1) and Lemma 2.2, we need only to consider the case of $g = 21$. If there is a G -action on $(\mathbb{R}^3, \Sigma_{21})$ such that $|G| > 88 = 4(21 + 1)$, then $|G^\circ| > 2(21 + 1)$. By the proof of Theorem 1.5(1), $G^\circ = A_5$ and Σ_{21}/G° is a sphere with 4 singular points of index 3. Since the G -action can be conjugated into $O(3)$, it induces a reflection on \mathbb{R}^3/G° , and the reflection plane contains the singular set of \mathbb{R}^3/G° . The reflection plane cuts Σ_{21}/G° into two homeomorphic connected bordered surfaces. Hence, the intersection of Σ_{21}/G° and the reflection plane is one circle. Then the image of $\pi_1(\Sigma_{21}/G^\circ)$ in $\pi_1(\mathbb{R}^3/G^\circ)$ is isomorphic to \mathbb{Z}_3 . By Lemma 2.7 the preimage of Σ_{21}/G° in \mathbb{R}^3 is not connected, and we get a contradiction. \square

4 Bordered surfaces in \mathbb{R}^3

In this section, we first construct some extendable actions which will be used to realize CEA_α° , CEA_α , EA_α° and EA_α . The examples mainly come from Examples 3.1 and 3.2. Then we give the proofs of Theorems 1.7 and 1.8.

Example 4.1. (1) For the graph in Example 3.1(1), we can replace each vertex with a disk and replace each edge with a band to get a bordered surface $\Sigma_{0,g+1}$ such that each of the group actions constructed in Examples 3.1(i)–3.1(iv) keeps $\Sigma_{0,g+1}$ invariant.

(2) For each of the graphs in Examples 3.2(1) and 3.2(2), we can replace each vertex with a disk and replace each edge with a band to get a bordered surface $\Sigma_{0,g+1}$, where g is one of 3, 5, 7, 11 and 19, such that the corresponding group action in Examples 3.2(1) and 3.2(2) keeps $\Sigma_{0,g+1}$ invariant.

(3) For the graph in Example 3.2(3), we can replace each vertex with a disk and replace each edge with a band to get a bordered surface Σ such that the group action in Example 3.2(3) keeps Σ invariant.

Note that the replacement in the above (1)–(3) does not change the fundamental groups. Since the genus of the graph equals the rank of its fundamental group, the algebraic genus of each surface in (1)–(3) equals the genus of the corresponding graph.

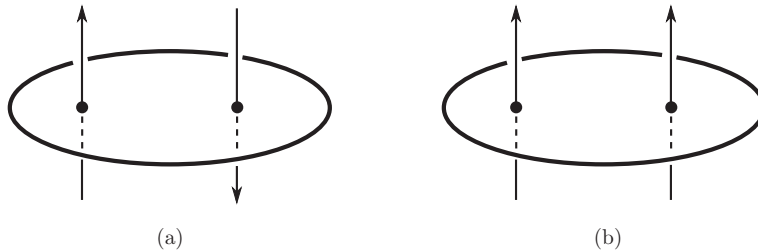

Figure 5 Intersection of X and the singular line

Proposition 4.2. For each $\alpha > 1$, we have $\text{CEA}_\alpha^\circ \leq \text{CE}_\alpha^\circ$, $\text{CEA}_\alpha \leq \text{CE}_\alpha$, $\text{EA}_\alpha^\circ \leq E_\alpha^\circ$ and $\text{EA}_\alpha \leq E_\alpha$.

Proof. We only show that $\text{EA}_\alpha \leq E_\alpha$. The proofs of the others are similar.

For any bordered surface $\Sigma \subset \mathbb{R}^3$ with $\alpha(\Sigma) = \alpha$ and any G -action on (\mathbb{R}^3, Σ) , the group G also acts on $(\mathbb{R}^3, \partial N(\Sigma))$, where $N(\Sigma)$ is an equivariant regular neighborhood of Σ such that $N(\Sigma)$ is a handlebody of genus α and $\partial N(\Sigma)$ is a smoothly embedded surface in \mathbb{R}^3 . Then $\partial N(\Sigma)$ is homeomorphic to Σ_α . Hence, $|G| \leq E_\alpha$ and $\text{EA}_\alpha \leq E_\alpha$. \square

Remark 4.3. By comparing Theorems 1.4, 1.5, 1.7 and 1.8, the inequalities in Proposition 4.2 are all sharp.

Proof of Theorem 1.7. (1) By Example 4.1(1), there exists a $\mathbb{Z}_{\alpha+1}$ -action on $(\mathbb{R}^3, \Sigma_{0, \alpha+1})$, and

$$\alpha(\Sigma_{0, \alpha+1}) = \alpha.$$

By Proposition 4.2 and Theorem 1.4(1), we have $\text{CEA}_\alpha^\circ \leq \text{CE}_\alpha^\circ = \alpha + 1$. So $\text{CEA}_\alpha^\circ = \alpha + 1$. In the following we need to determine all Σ realizing CEA_α° .

Suppose that $\mathbb{Z}_{\alpha+1}$ acts on (\mathbb{R}^3, Σ) with $\alpha(\Sigma) = \alpha$. Let $X = \Sigma/\mathbb{Z}_{\alpha+1}$, and let $N(\Sigma)$ be the regular neighborhood of Σ as in the proof of Proposition 4.2. Then $N(\Sigma)/\mathbb{Z}_{\alpha+1}$ is a regular neighborhood of X , denoted by $N(X)$. By Proposition 3.3, $N(X)$ must be a 3-ball with 2 singular arcs of index $\alpha + 1$. Since $|N(X)| = N(|X|)$, $|X|$ must be a disk. Then since $\alpha + 1 > 2$, the boundary points of $|X|$ are regular in X , and X is a disk with 2 singular points of index $\alpha + 1$. By Lemma 2.5, Σ is orientable, and we can assume that $\Sigma = \Sigma_{g, b}$.

Fix an orientation on the singular line in $\mathbb{R}^3/\mathbb{Z}_{\alpha+1}$, there are two ways that X intersects the singular line (see Figure 5). Let $\mathbb{Z}_{\alpha+1} = \langle t \mid t^{\alpha+1} \rangle$, and let $i : X \hookrightarrow \mathbb{R}^3/\mathbb{Z}_{\alpha+1}$ be the inclusion map. Consider the induced homomorphism $i_* : \pi_1(\partial X) \rightarrow \pi_1(\mathbb{R}^3/\mathbb{Z}_{\alpha+1}) = \mathbb{Z}_{\alpha+1}$.

In Figure 5(a), the singular line goes through the two singular points in opposite directions. Then $i_*(\pi_1(\partial X))$ is trivial in $\mathbb{Z}_{\alpha+1}$. So

$$[\pi_1(\mathbb{R}^3/\mathbb{Z}_{\alpha+1}) : i_*(\pi_1(\partial X))] = \alpha + 1.$$

By Lemma 2.7, the preimage of ∂X in \mathbb{R}^3 has $\alpha + 1$ connected components. Hence $b = \alpha + 1$. Since $\alpha(\Sigma_{g, b}) = 2g - 1 + b$, we have $g = 0$ and $\Sigma = \Sigma_{0, \alpha+1}$.

In Figure 5(b), the singular line goes through the two singular points in the same direction. Then $i_*(\pi_1(\partial X))$ in $\mathbb{Z}_{\alpha+1}$ is generated by t^2 . So

$$[\pi_1(\mathbb{R}^3/\mathbb{Z}_{\alpha+1}) : i_*(\pi_1(\partial X))] = ((-1)^{\alpha+1} + 3)/2.$$

By Lemma 2.7, the preimage of ∂X in \mathbb{R}^3 is connected when α is even and has 2 connected components when α is odd. Since $\alpha(\Sigma_{g, b}) = 2g - 1 + b$, we have $\Sigma = \Sigma_{\alpha/2, 1}$ for even α and $\Sigma = \Sigma_{(\alpha-1)/2, 2}$ for odd α . An intuitive view of the surfaces is shown as Figure 6 (for $\alpha = 2$).

(2) When α is even, by Example 4.1(1) there exists a $\mathbb{Z}_{2\alpha+2}$ -action on $(\mathbb{R}^3, \Sigma_{0, \alpha+1})$, and $\alpha(\Sigma_{0, \alpha+1}) = \alpha$. By Proposition 4.2 and Theorem 1.4(2), we have $\text{CEA}_\alpha \leq \text{CE}_\alpha = 2\alpha + 2$. So CEA_α is $2\alpha + 2$ for even α . In the following we need to determine all Σ realizing CEA_α with even α .

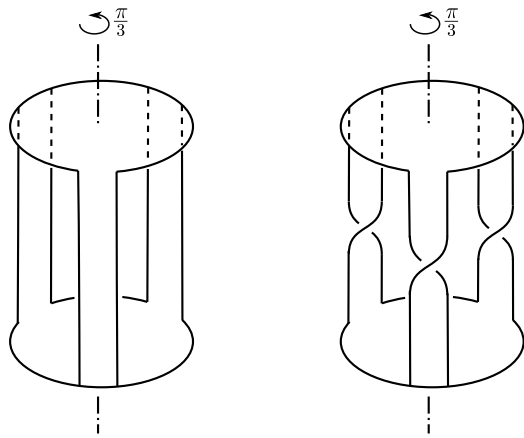

Figure 6 Extendable cyclic action on bordered surfaces

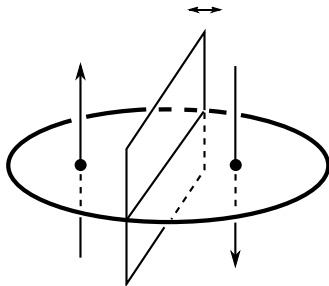

Figure 7 Reflection on $X = \Sigma/\mathbb{Z}_{\alpha+1}$

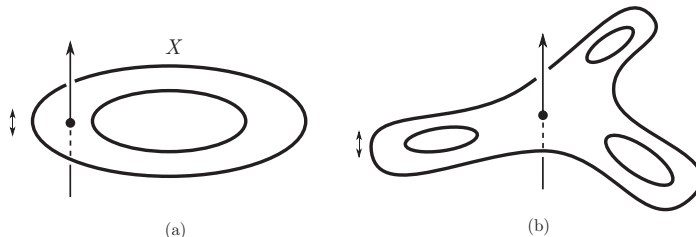

Figure 8 Non-faithful extendable cyclic action on $\Sigma_{0, \alpha+1}$

Suppose that $\mathbb{Z}_{2\alpha+2}$ acts on (\mathbb{R}^3, Σ) with $\alpha(\Sigma) = \alpha$. Let t be a generator of $\mathbb{Z}_{2\alpha+2}$, then t^2 generates $\mathbb{Z}_{\alpha+1}$. Let $X = \Sigma/\mathbb{Z}_{\alpha+1}$. Then by the proof of Theorem 1.7(1), X is a disk with two singular points. By Lemma 2.4, the \mathbb{Z}_2 -action on X induced by t cannot fix both the singular points of X . Hence it has no singular fixed points in X , and there exist regular fixed points in X . Then the \mathbb{Z}_2 -action must be a reflection on $\mathbb{R}^3/\mathbb{Z}_{\alpha+1}$ and X . Since the \mathbb{Z}_2 -action changes the orientation of the singular line in $\mathbb{R}^3/\mathbb{Z}_{\alpha+1}$, the singular line goes through the two singular points of X in opposite directions (see Figure 7). So by the proof of Theorem 1.7(1), $\Sigma = \Sigma_{0, \alpha+1}$.

When α is odd, by Proposition 4.2 and Theorem 1.4(2), $\text{CEA}_\alpha \leq 2\alpha$. On the other hand, there exists a $\mathbb{Z}_{2\alpha}$ -action on $(\mathbb{R}^3, \Sigma_{0, \alpha+1})$ indicated by Figure 8(b) (for $\alpha = 3$). The surface lies on a plane, and the action is generated by a $2\pi/\alpha$ -rotation and the reflection about the plane. Then CEA_α is 2α for odd α . In the following we need to determine all Σ realizing CEA_α with odd α .

Suppose that $\mathbb{Z}_{2\alpha}$ acts on (\mathbb{R}^3, Σ) with $\alpha(\Sigma) = \alpha$. Let t be a generator of $\mathbb{Z}_{2\alpha}$. Then t^2 generates \mathbb{Z}_α . Let $X = \Sigma/\mathbb{Z}_\alpha$, and let $N(X)$ be the regular neighborhood of X as in the proof of Theorem 1.7(1). By Proposition 3.3, $\partial N(X)$ is a torus with two singular points of index α , since $\alpha \geq 3$. Then $N(X) \subset \mathbb{R}^3/\mathbb{Z}_\alpha$ must be a solid torus with one singular arc, and $|X|$ must be an annulus or a Möbius band. Since $\alpha \geq 3$, the boundary points of $|X|$ are regular in X , and X has exactly 1 singular point w of index α . Then the

involution induced by t fixes this singular point w ; since $\chi(X - w) = -1$, by Lemma 2.3 the involution must have other regular fixed points in X . By Lemma 2.4, the \mathbb{Z}_2 -action on $\mathbb{R}^3/\mathbb{Z}_\alpha$ is a reflection, and the reflection plane contains the singular point of X . Then X cannot intersect the reflection plane transversely. Hence X lies on the reflection plane, and $|X|$ is an annulus (see Figure 8(a)). By Lemma 2.5, Σ is orientable, and we can assume that $\Sigma = \Sigma_{g,b}$.

In this case ∂X has two components. The fundamental group of one component is mapped to a generator of \mathbb{Z}_α , and the fundamental group of the other component is mapped to the identity element of \mathbb{Z}_α . By Lemma 2.7, the preimages of the two components in \mathbb{R}^3 have 1 and α components, respectively. Hence $b = \alpha + 1$ and $\Sigma = \Sigma_{0,\alpha+1}$.

Note that in this case the bordered surface lies on a plane, and the action on the surface must be non-faithful. \square

Proposition 4.4. *If we require that the actions on surfaces are faithful in the definition of CEA_α , then CEA_α is $\alpha + 1$ for odd α .*

Proof. By Theorem 1.7(1), we only need to consider orientation-reversing group actions. Suppose that \mathbb{Z}_{2n} acts on (\mathbb{R}^3, Σ) with $\alpha(\Sigma) = \alpha$ orientation-reversingly. Let $N(\Sigma)$ be the regular neighborhood of Σ as in the proof of Proposition 4.2. Then \mathbb{Z}_{2n} acts on $(\mathbb{R}^3, \partial N(\Sigma))$, and $\mathbb{Z}_n \subset \mathbb{Z}_{2n}$ acts on $(\mathbb{R}^3, \partial N(\Sigma))$ orientation-preservingly. By Proposition 3.4, n cannot be $\alpha + 1$ and $\alpha - 1$. By the proof of Theorem 1.7(2), n cannot be α , since we require that the actions on surfaces are faithful. Then by proposition 3.3, $n \leq \alpha/2 + 1$. Since α is odd, $n \leq (\alpha + 1)/2$ and $2n \leq \alpha + 1$. \square

Proof of Theorem 1.8. (1) By Example 4.1, Proposition 4.2 and Theorem 1.5, we have $\text{EA}_\alpha^o = E_\alpha^o$. Hence we have the orders in the table. In the following we need to determine all Σ realizing EA_α^o .

Suppose that G acts on (\mathbb{R}^3, Σ) with $\alpha(\Sigma) = \alpha$, and $|G| = \text{EA}_\alpha^o$. Let $X = \Sigma/G$, and let $N(X)$ be the regular neighborhood of X as in the proof of Theorem 1.7(1). By the proof of Theorem 1.5, $N(X)$ must be a 3-ball with 2 singular arcs of indices r and s , where $1 < r \leq s$. Since $|N(X)| = N(|X|)$, $|X|$ must be a disk. The possible cases of G and (r, s) are listed below:

- (i) $\alpha > 1$: $G = D_{\alpha+1}$ and $(r, s) = (2, \alpha + 1)$;
- (ii) $\alpha = 3$: $G = A_4$ and $(r, s) = (2, 3)$;
- (iii) $\alpha = 5$: $G = S_4$ and $(r, s) = (2, 3)$;
- (iv) $\alpha = 7$: $G = S_4$ and $(r, s) = (2, 4)$;
- (v) $\alpha = 11$: $G = A_5$ and $(r, s) = (2, 3)$;
- (vi) $\alpha = 19$: $G = A_5$ and $(r, s) = (2, 5)$;
- (vii) $\alpha = 21$: $G = A_5$ and $(r, s) = (3, 3)$;
- (viii) $\alpha = 29$: $G = A_5$ and $(r, s) = (3, 5)$.

Then there are two possibilities of X as in Figure 9.

Case (a) The boundary points of $|X|$ are regular in X , and X is a disk with 2 singular points of indices r and s . By Lemma 2.5, Σ is orientable, and we can assume that $\Sigma = \Sigma_{g,b}$.

Case (b) $\partial|X| = \gamma_1 \cup \gamma_2$, γ_1 is the real boundary, and γ_2 is the reflection boundary. X is a disk with a singular arc γ_2 of index 2 on $\partial|X|$ and a singular point of index s in the interior of X . Note $\partial X = \gamma_1$, the bold arc in Figure 9(b). In this case, Σ can be orientable as well as non-orientable, and we assume that $\Sigma = \Sigma_{g,b}$ or $\Sigma = \Sigma_{g,b}^-$.

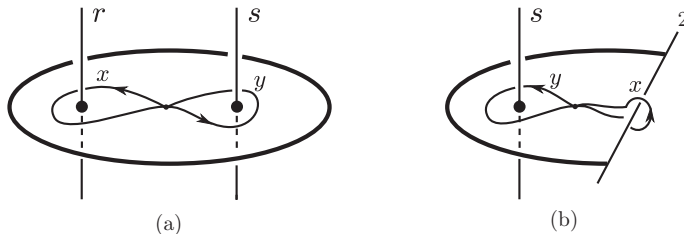

Figure 9 Two possibilities of X

Let $i : X \hookrightarrow \mathbb{R}^3/G$ be the inclusion map. Since the preimage of X in \mathbb{R}^3 is Σ , which is connected, by Lemma 2.7, i_* is surjective. Note that $\pi_1(X)$ is isomorphic to the free product of \mathbb{Z}_r and \mathbb{Z}_s , which correspond to the two singular points in Case (a) and correspond to the reflection boundary arc and the singular point in Case (b). Let u be a generator of \mathbb{Z}_r , let v be a generator of \mathbb{Z}_s , and let $x = i_*(u)$, $y = i_*(v)$. Then x has order r , y has order s , and $\{x, y\}$ generates the group G .

In Case (a), $i_*(\pi_1(\partial X))$ is generated by xy . In Case (b), let $N(\partial X) = N(\gamma_1)$ be the regular neighborhood of ∂X in \mathbb{R}^3/G . Then $N(\partial X)$ is a 3-ball ($|N(\partial X)| = B^3$) with two index 2 lines in it, and it is easy to see that $i_*(\pi_1(N(\partial X))) = i_*(\pi_1(N(\partial X)))$ is generated by $\{x, y^{-1}xy\}$. Hence by Lemma 2.7, $b = [G : \langle xy \rangle]$ in Case (a), and $b = [G : \langle x, y^{-1}xy \rangle]$ in Case (b). Note that Σ is always orientable in Case (a). In each case of (i)–(viii) we will determine whether Σ is orientable in Case (b), and then by $\alpha(\Sigma_{g,b}) = 2g - 1 + b$ and $\alpha(\Sigma_{g,b}^-) = g - 1 + b$, we can get the genus g .

Below we identify Σ case by case. Except for the cases of (vi) and (viii), all the surfaces are those in Example 4.1 or can be constructed from those in Example 4.1 by replacing each band by a half-twisted band.

(i) Note that $D_{\alpha+1} = \langle a, b \mid a^2, b^{\alpha+1}, (ab)^2 \rangle$. We can assume that $x = a$ and $y = b$.

(a) $b = [G : \langle ab \rangle] = \alpha + 1$. Hence $\Sigma = \Sigma_{0, \alpha+1}$.

(b) If α is even, then $b = [G : \langle a, b^{-1}ab \rangle] = 1$; if α is odd, then $b = [G : \langle a, b^{-1}ab \rangle] = 2$. Since $D_{\alpha+1}$ contains $\mathbb{Z}_{\alpha+1}$ as an index 2 subgroup, $\mathbb{R}^3/\mathbb{Z}_{\alpha+1}$ is a 2-sheet regular orbifold covering space of $\mathbb{R}^3/D_{\alpha+1}$, and in $\mathbb{R}^3/\mathbb{Z}_{\alpha+1}$ there is a 2-sheet regular orbifold covering space of X , denoted by X' . Then X' is a disk with 2 singular points of index $\alpha + 1$. By Lemma 2.5, Σ is orientable. Hence $\Sigma = \Sigma_{\alpha/2, 1}$ for even α and $\Sigma = \Sigma_{(\alpha-1)/2, 2}$ for odd α .

An intuitive view of the surfaces is as Figure 6.

(ii) By Lemma 2.8(1), we can assume that $\{x, y\} = \{(12)(34), (123)\}$.

(a) $b = [A_4 : \langle (134) \rangle] = 4$. Hence $\Sigma = \Sigma_{0, 4}$.

(b) $b = [A_4 : \langle (12)(34), (14)(23) \rangle] = 3$. If Σ is orientable, then $\alpha = 2g - 1 + 3$ is even, which leads to a contradiction. Hence Σ is non-orientable, and $\Sigma = \Sigma_{1, 3}^-$.

An intuitive view of the surfaces can be seen in Figure 10 (see also [3, Figure 3]).

(iii) By Lemma 2.8(2), we can assume that $\{x, y\} = \{(12), (134)\}$.

(a) $b = [S_4 : \langle (1234) \rangle] = 6$. Hence $\Sigma = \Sigma_{0, 6}$.

(b) $b = [S_4 : \langle (12), (23) \rangle] = 4$. Consider the 2-sheet covering space of X in \mathbb{R}^3/A_4 , denoted by X' , as Figure 11. Then X' is a disk with 2 singular points of index 3. By Lemma 2.5, Σ is orientable. Hence $\Sigma = \Sigma_{1, 4}$.

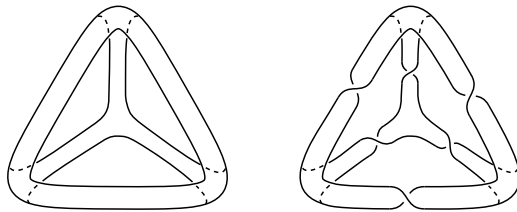

Figure 10 $\Sigma_{0, 4}$ and $\Sigma_{1, 3}^-$

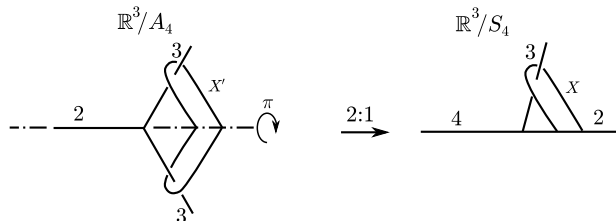

Figure 11 2-sheet covering with $|X'|$ a disk

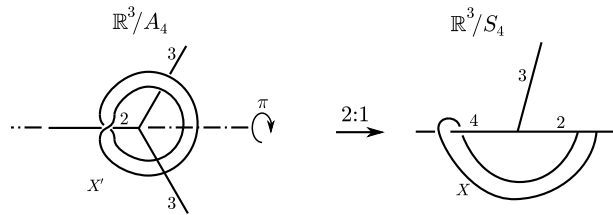

Figure 12 2-sheet covering with $|X'|$ a Möbius band

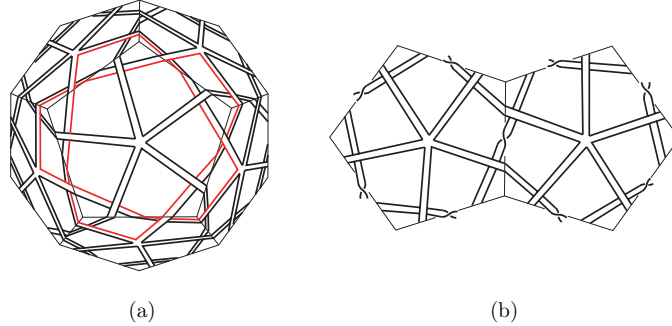

Figure 13 $\Sigma_{4,12}$ and $\Sigma_{10,10}^-$

(iv) By Lemma 2.8(3), we can assume that $\{x, y\} = \{(12), (1234)\}$.

(a) $b = [S_4 : \langle(134)\rangle] = 8$. Hence $\Sigma = \Sigma_{0,8}$.

(b) $b = [S_4 : \langle(12), (23)\rangle] = 4$. Consider the 2-sheet covering space of X in \mathbb{R}^3/A_4 , denoted by X' (see Figure 12). If we view $|X'|$ as a bordered surface in $|\mathbb{R}^3/A_4|$, then by Lemma 2.7, $|X'|$ has one boundary component. Hence X' is a Möbius band with one singular point of index 2 in \mathbb{R}^3/A_4 . Since A_4 has no index 2 subgroups, by Lemma 2.6, Σ is non-orientable. Hence $\Sigma = \Sigma_{4,4}^-$.

(v) By Lemma 2.8(4), we can assume that $\{x, y\} = \{(12)(34), (135)\}$.

(a) $b = [A_5 : \langle(12345)\rangle] = 12$. Hence $\Sigma = \Sigma_{0,12}$.

(b) $b = [A_5 : \langle(12)(34), (23)(45)\rangle] = 6$. Since A_5 has no index 2 subgroups, by Lemma 2.6, Σ is non-oriented. Hence $\Sigma = \Sigma_{6,6}^-$.

(vi) By Lemma 2.8(5), we can assume that one of the following two cases holds: $\{x, y\} = \{(12)(34), (12345)\}$, $\{x, y\} = \{(13)(24), (12345)\}$.

(a) In the first case $b = [A_5 : \langle(135)\rangle] = 20$, and $\Sigma = \Sigma_{0,20}$; in the second case, $b = [A_5 : \langle(14325)\rangle] = 12$, and $\Sigma_{4,12}$.

(b) In the first case $b = [A_5 : \langle(12)(34), (23)(45)\rangle] = 6$; in the second case $b = [A_5 : \langle(13)(24), (24)(35)\rangle] = 10$. Since A_5 has no index 2 subgroups, by Lemma 2.6, Σ is non-orientable. Hence $\Sigma = \Sigma_{14,6}^-$ or $\Sigma_{10,10}^-$.

An intuitive view of the surfaces is as following: $\Sigma = \Sigma_{0,20}$ is obtained by replacing vertices and edges of the icosahedron by disks and bands, as in Example 4.1. Then $\Sigma = \Sigma_{14,6}^-$ can be obtained by replacing each band of $\Sigma_{0,20}$ by a half-twisted band. The other two surfaces are somehow non-trivial. An embedding of $\Sigma_{4,12}$ is as Figure 13(a). Each boundary of it is a $(5, 2)$ -torus knot, and the red circle is one of the 12 boundaries. Then $\Sigma_{10,10}^-$ can be obtained by replacing the bands of $\Sigma_{4,12}$ by half-twisted bands as Figure 13(b).

(vii) By Lemma 2.8(6), we can assume that $\{x, y\} = \{(123), (145)\}$. There is only one case. $b = [A_5 : \langle(12345)\rangle] = 12$. Hence $\Sigma = \Sigma_{5,12}$.

(viii) By Lemma 2.8(7), we can assume that one of the following four cases holds: $\{x, y\} = \{(123), (12345)\}$, $\{x, y\} = \{(132), (12345)\}$, $\{x, y\} = \{(124), (12345)\}$ and $\{x, y\} = \{(142), (12345)\}$.

There is only one case of X , xy is one of (13245) , (145) , (13425) and $(15)(34)$. Then b is one of 12, 20, 12 and 30. Since Σ is always orientable, Σ is one of $\Sigma_{9,12}$, $\Sigma_{5,20}$, $\Sigma_{9,12}$ and $\Sigma_{0,30}$.

An intuitive view of the surfaces is as Figure 14. $\Sigma_{0,30}$ is as (a); the two $\Sigma_{9,12}$ are as (b) and (c); $\Sigma_{5,20}$ is as (d). (c) differs from (a) by the twists on each face, and (d) differs from (b) by the twists on each face.

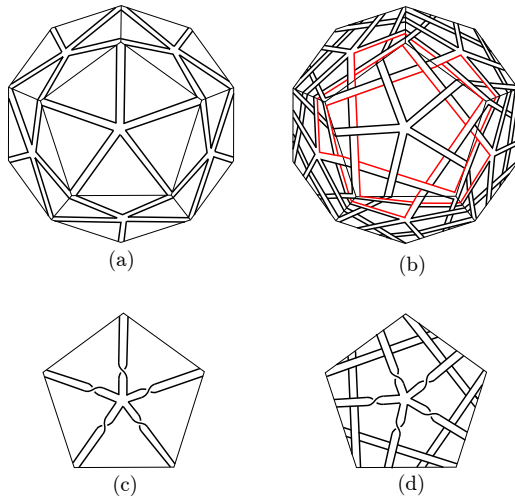

Figure 14 Surfaces realizing EA_{29}^o

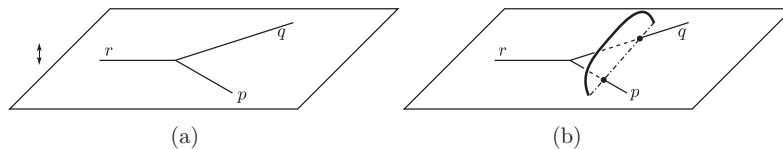

Figure 15 Reflection planes of \mathcal{O}

(2) By Example 4.1, Proposition 4.2 and Theorem 1.5, $EA_\alpha = E_\alpha$. Hence we have the orders in the table. In the following we need to determine all Σ realizing EA_α .

Suppose that G acts on (\mathbb{R}^3, Σ) realizing the maximum order. Then the G -action is orientation-reversing. Hence the orientation-preserving elements of G form an index 2 subgroup G^o . Let $\mathcal{O} = \mathbb{R}^3/G^o$ and $X = \Sigma/G^o$. Then the G -action induces an orientation-reversing \mathbb{Z}_2 -action on \mathcal{O} . By the proof of Theorem 1.8(1), $|\mathcal{O}| \cong \mathbb{R}^3$, the singular set of \mathcal{O} consists of 3 half lines, and the induced \mathbb{Z}_2 -action is a reflection on $|\mathcal{O}|$. The reflection plane Π contains the singular set of \mathcal{O} (see Figure 15(a)).

By the proof of Theorem 1.8(1), there are two possibilities: Cases (a) and (b). In Case (b), the reflection boundary arc of X lies on Π , so the whole X lies on Π . This leads to a contradiction since X also contains a singular point in the interior of $|X|$. In Case (a), X has 2 singular points which lie on Π . Since X cannot lie on Π , it must intersect Π transversely along an arc passing the two singular points (see Figure 15(b)). If the two singular points lie on the same singular line, then the preimage of X cannot be connected (compared with the last paragraph of the proof of Theorem 1.5). Hence (vii) in the proof of Theorem 1.8(1) does not happen. Then the singular points of X lie on different singular lines, and the order of xy in the proof of Theorem 1.8(1) will be the same as the index of the singular line of \mathcal{O} which does not intersect X . Then Σ must be a punctured sphere. \square

5 A remark on graphs in \mathbb{R}^3

Note that for a finite graph, its genus defined at the beginning of Section 3 coincides with its algebraic genus, defined as the rank of its fundamental group. We can define extendable group actions on graphs like the case of compact bordered surfaces, and define the maximum orders EG_α , CEG_α , EG_α^o , CEG_α^o similarly. Then we have the following.

Theorem 5.1. *For each $\alpha > 1$, we have $CEG_\alpha^o = CEA_\alpha^o$, $EG_\alpha^o = EA_\alpha^o$, $CEG_\alpha = CEA_\alpha$ and $EG_\alpha = EA_\alpha$.*

Proof. All the examples we constructed come from the equivariant graphs in \mathbb{R}^3 . So all these examples

also apply for graphs with the same genera.

On the other hand, if a group G acts on (\mathbb{R}^3, Γ) for a graph Γ of genus g , then G also acts on $\partial N(\Gamma)$, as described at the beginning of Section 3. This completes the proof. \square

Remark 5.2. The maximum order of finite group actions on minimal graphs (i.e., the graphs without free edges) of genus α is $2^\alpha \alpha!$ if $\alpha > 2$ and is 12 if $\alpha = 2$ (see [16]).

Acknowledgements This work was supported by National Natural Science Foundation of China (Grant Nos. 11371034 and 11501239).

References

- 1 Bai S, Robins V, Wang C, et al. The maximally symmetric surfaces in the 3-torus. *Geom Dedicata*, 2017, doi:10.1007/s10711-017-0218-0
- 2 Boileau M, Maillot S, Porti J. *Three-Dimensional Orbifolds and Their Geometric Structures*. Panoramas et Synthèses, vol. 15. Paris: Société Mathématique de France, 2003
- 3 Cavendish W, Conway J H. Symmetrically bordered surfaces. *Amer Math Monthly*, 2010, 117: 571–580
- 4 Dunbar W D. Geometric orbifolds. *Rev Mat Univ Complut Madrid*, 1988, 1: 67–99
- 5 Hurwitz A. Über algebraische Gebilde mit eindeutigen Transformationen in sich. *Math Ann*, 1893, 41: 403–442
- 6 Kwasik S, Schultz R. Icosahedral group actions on \mathbb{R}^3 . *Invent Math*, 1992, 108: 385–402
- 7 May C L. Automorphisms of compact Klein surfaces with boundary. *Pacific J Math*, 1975, 59: 199–210
- 8 Meeks W, Yau S T. Group actions on \mathbb{R}^3 . In: *The Smith Conjecture*. Pure and Applied Mathematics, vol. 112. Orlando: Academic Press, 1984, 167–179
- 9 Steiger F. Die maximalen Ordnungen periodischer topologischer Abbildungen geschlossener Flächen in sich. *Comment Math Helv*, 1935, 8: 48–69
- 10 Thurston W P. *The Geometry and Topology of Three-Manifolds*. [Http://library.msri.org/books/gt3m/](http://library.msri.org/books/gt3m/), 2002
- 11 Wang C, Wang S C, Zhang Y M. Maximal orders of extendable actions on surfaces. *Acta Math Sin (Engl Ser)*, 2016, 32: 54–68
- 12 Wang C, Wang S C, Zhang Y M. Maximum orders of cyclic group actions on surfaces extending over the 3-dimensional torus. *J Knot Theory Ramifications*, 2017, doi: 10.1142/S0218216517420056
- 13 Wang C, Wang S C, Zhang Y M, et al. Extending finite group actions on surfaces over S^3 . *Topology Appl*, 2013, 160: 2088–2103
- 14 Wang C, Wang S C, Zhang Y M, et al. Embedding surfaces into S^3 with maximum symmetry. *Groups Geom Dyn*, 2015, 9: 1001–1045
- 15 Wang C, Zhang Y M. Maximum orders of cyclic and abelian extendable actions on surfaces. *ArXiv:1310.7302*, 2013
- 16 Wang S C, Zimmerman B. The maximum order of finite groups of outer automorphisms of free groups. *Math Z*, 1994, 216: 83–87
- 17 Zimmermann B. Ueber Abbildungsklassen von Henkelkoepfern. *Arch Math*, 1979, 33: 379–382