

Embedding surfaces into S^3 with maximum symmetry

Chao Wang, Shicheng Wang, Yimu Zhang, and Bruno Zimmermann

Abstract. We restrict our discussion to the orientable category. For $g > 1$, let OE_g be the maximum order of a finite group G acting on the closed surface Σ_g of genus g which extends over (S^3, Σ_g) , for all possible embeddings $\Sigma_g \hookrightarrow S^3$. We will determine OE_g for each g , indeed the action realizing OE_g .

In particular, with 23 exceptions, OE_g is $4(g+1)$ if $g \neq k^2$ or $4(\sqrt{g}+1)^2$ if $g = k^2$, and moreover OE_g can be realized by unknotted embeddings for all g except for $g = 21$ and 481.

Mathematics Subject Classification (2010). 57M60, 57M15, 57S25, 20F65, 05C10.

Keywords. Surface symmetry, extendable action, 3-orbifolds, maximal order.

Contents

| | | |
|---|---|----|
| 1 | Introduction | 2 |
| 2 | Orbifolds and finite group actions | 5 |
| 3 | Dunbar’s list of spherical 3-orbifolds | 13 |
| 4 | Strategy and outline of finding OE_g | 17 |
| 5 | Fibred 3-orbifolds containing allowable 2-suborbifolds | 20 |
| 6 | List of allowable 2-suborbifolds | 30 |
| 7 | See the maximum symmetries of Σ_g in S^3 for general g | 39 |
| | References | 44 |

1. Introduction

Surfaces belong to the most familiar topological subjects to us, mostly because we can see them staying in our 3-space in various manners. The symmetries of the surfaces have been studied for a long time, and it will be natural to wonder when these symmetries can be embedded into the symmetries of our 3-space (3-sphere). In particular, what are the orders of the maximum symmetries of surfaces which can be embedded into the symmetries of the 3-sphere S^3 ? We will solve this maximum order problem in this paper in the orientable category.

We use $\Sigma_g (V_g)$ to denote the closed orientable surface (handlebody) of genus $g > 1$, and G to denote a finite group acting on Σ_g or on an orientable 3-manifold. The actions we consider are always faithful and orientation-preserving on both surfaces and 3-manifolds. We are always working in the smooth category. By the geometrization of finite group actions in dimension 3, for actions on the 3-sphere, we can then restrict to orthogonal actions.

Let O_g be the maximal order of all finite groups which can act on Σ_g . A classical result of Hurwitz states that O_g is at most $84(g - 1)$; cf. [5]. However, to determine O_g is still a hard and famous question in general, and there are numerous interesting partial results.

Let OH_g be the maximal order of all finite groups which can act on V_g . It is a result due to Zimmermann [12] that $4(g + 1) \leq \text{OH}_g \leq 12(g - 1)$, see also [6]. There are finer results in this direction, however in general OH_g are still not determined either.

In [10], we started to consider finite group actions on the pair (S^3, Σ_g) , with respect to an embedding $e: \Sigma_g \hookrightarrow S^3$. If G can act on the pair (S^3, Σ_g) such that its restriction on Σ_g is the given G -action on Σ_g , we call the action of G on Σ_g extendable (over S^3 with respect to e).

Call an embedding $e: \Sigma_g \hookrightarrow S^3$ unknotted, if each component of $S^3 \setminus e(\Sigma_g)$ is a handlebody, otherwise it is knotted. Similarly, we define an action of G on V_g to be extendable and the embedding $e: V_g \hookrightarrow S^3$ to be unknotted or knotted. For each g , the unknotted embedding is unique up to isotopy of S^3 and automorphisms of Σ_g (resp. V_g).

Let OE_g be the maximal order of all extendable finite groups acting on Σ_g . Let OE_g^u be the maximal order of all finite group actions on Σ_g which extend over S^3 with respect to the unknotted embedding. Then we know that $4(g + 1) \leq \text{OE}_g^u \leq \text{OH}_g \leq 12(g - 1)$, and there are only finitely many g such that $\text{OE}_g^u = 12(g - 1)$, see [10].

In this paper we will determine OE_g for all $g > 1$ (Theorem 1.1). We can also determine OE_g^u and OE_g^k (Theorem 1.2 and Theorem 1.3), where OE_g^k denotes the maximal order of finite group actions on Σ_g which extend over S^3 with respect to all possible knotted embeddings.

Theorem 1.1. *The maximal orders OE_g are given in the following table:*

| OE_g | g |
|-------------------|---|
| $12(g-1)$ | 2, 3, 4, 5, 6, 9, 11, 17, 25, 97, 121, 241, 601 |
| $8(g-1)$ | 7, 49, 73 |
| $20(g-1)/3$ | 16, 19, 361 |
| $6(g-1)$ | 21, 481 |
| 192 | 41 |
| 7200 | 1681 |
| $4(\sqrt{g}+1)^2$ | $g = k^2, k \neq 3, 5, 7, 11, 19, 41$ |
| $4(g+1)$ | <i>the remaining numbers</i> |

Theorem 1.2. *The maximal orders OE_g^u are given in the following table:*

| OE_g^u | g |
|-------------------|---|
| $12(g-1)$ | 2, 3, 4, 5, 6, 9, 11, 17, 25, 97, 121, 241, 601 |
| $8(g-1)$ | 7, 49, 73 |
| $20(g-1)/3$ | 16, 19, 361 |
| 192 | 41 |
| 7200 | 1681 |
| $4(\sqrt{g}+1)^2$ | $g = k^2, k \neq 3, 5, 7, 11, 19, 41$ |
| $4(g+1)$ | <i>the remaining numbers</i> |

Theorem 1.3. *The maximal orders OE_g^k are given in the following table:*

| OE_g^k | g |
|-----------------|------------------------------|
| $12(g-1)$ | 9, 11, 121, 241 |
| 2400 | 361 |
| $6(g-1)$ | 2, 3, 4, 5, 21, 25, 97, 481 |
| $4(g-1)$ | <i>the remaining numbers</i> |

In fact, we will do something more. We will classify all the finite group actions with order larger than $4(g-1)$. And the statements above can be obtained directly from the following theorem.

Theorem 1.4. *For an extendable finite group action G , if $|G| > 4(g-1)$, all possible relations between $|G|$ and g are listed in the following table. The foot index 'k' means the action is realized only for a knotted embedding, 'uk' means the action can be realized for both unknotted and knotted embeddings. If the action is realized only for an unknotted embedding, there is no foot index.*

| $ G $ | g |
|-----------------|---|
| $12(g-1)$ | $2, 3, 4, 5, 6, 9_{uk}, 11_{uk}, 17, 25, 97, 121_{uk}, 241_{uk}, 601$ |
| $8(g-1)$ | $3, 7, 9, 49, 73$ |
| $20(g-1)/3$ | $4, 16, 19, 361_{uk}$ |
| $6(g-1)$ I | $2, 3, 4, 5, 9_{uk}, 11, 17, 25, 97, 121_{uk}, 241_{uk}$ |
| $6(g-1)$ II | $\{2, 3, 4, 5, 9, 11, 25, 97, 121, 241\}_{uk}, 21_k, 481_k$ |
| $24(g-1)/5$ | $6, 11, 41, 121$ |
| $30(g-1)/7$ | $8, 29, 841, 1681$ |
| $4n(g-1)/(n-2)$ | $n-1, (n-1)^2$ |

Here the $6(g-1)$ case contains two types, ‘‘I’’ and ‘‘II,’’ we will explain them in the next section.

Then some interesting phenomena appear: As expected, for all g with finitely many exceptions we have $OE_g^u > OE_g^k$; indeed there are only finitely many g such that $OE_g^u = OE_g^k$ and, a little bit surprising, $OE_g^u < OE_g^k$ when $g = 21$ or 481 . Also for some g , $OE_g^k = 12(g-1)$.

Our approach relies on the orbifold theory which is founded and studied in [9], [3], [4], [1] and [6]. More precisely, the proof of our main results translates into the problem of finding the so-called *allowable* 2-orbifolds (Definition 4.1) in certain spherical 3-orbifolds. The strategy of such an approach will be given in Section 4.

In Section 2, after introducing some basic notions about orbifolds and finite group actions on manifolds, we present a sequence of observations concerning the orbifold pair $(S^3, \Sigma_g)/G$ on both the topological level and the group theoretical level which are very useful for our later approach. In Section 3 we will describe Dunbar’s list of spherical 3-orbifolds whose underlying space is S^3 . With the material prepared in Sections 2 and 3, we will be able to explain why we can transfer the problem of finding OE_g into the problem of finding allowable 2-orbifolds in certain spherical 3-orbifolds and, more importantly, to outline how to get a practical method to find such 2-orbifolds. (Some people may prefer just read the definitions in Section 4 and skip the remaining part). In Section 5 we will give the list of 3-orbifolds containing allowable 2-suborbifolds which turns out to be a small subset of Dunbar’s list where the singular sets are relatively simple. In Section 6, we will find all allowable 2-orbifolds in the list of 3-orbifolds provided by Section 5, and then the main results are derived. Practically in Section 6, after some general argument, we only give detailed argument for several representative cases and the detailed argument of remaining cases can be found in the arXiv version [11].

Section 7 can be read directly after the introduction. Theorems 1.1 and 1.3 claim that OE_g is $4(g + 1)$ if $g \neq k^2$ or $4(\sqrt{g} + 1)^2$ if $g = k^2$ with 23 exceptions, and $\text{OE}_g^k = 4(g - 1)$ with 13 exceptions. Examples 7.1, 7.2 and 7.3 present $\Sigma_g \subset S^3$ to realize the maximal symmetries for those general g intuitively and then their orbifolds are derived. Example 7.4 presents $\Sigma_g \subset S^3$ realizing $\text{OE}_g^k = 12(g - 1)$ for $g = 11$.

Acknowledgements. We thank the referee for his sensitivity on orbifold theory and his aesthetic view on the structure of the paper, which enhance the paper. The first three authors are supported by grant No.11371034 of the National Natural Science Foundation of China and Beijing International Center for Mathematical Research.

2. Orbifolds and finite group actions

The orbifolds we consider have the form M/H , where M is a n -manifold and H is a finite group acting faithfully and locally smooth on M . For each point $x \in M$, denote its stable subgroup by $St(x)$, its image in M/H by x' . If $|St(x)| > 1$, x' is called a *singular point* and the *singular index* is $|St(x)|$, otherwise it is called a *regular point*. If we forget the singular set we get a topological space $|M/H|$ which is called *underlying space*. M/H is orientable if M is orientable and H preserve the orientation; M/H is connected if $|M/H|$ is connected.

We can also define covering spaces and fundamental group for an orbifold. There is a one to one correspondence between orbifold covering spaces and conjugacy classes of subgroup of the orbifold fundamental group, and regular covering spaces correspond to normal subgroups. A Van Kampen theorem is also valid, see [1]. In the following, covering space or fundamental group refers always to the orbifold setting.

Definition 2.1. A *discal orbifold (spherical orbifold)* has the form B^n/H (S^n/H), where B^n (S^n) is the n -dimension ball (sphere) and H a finite group acting orientation-preservingly on the corresponding manifold. A *handlebody orbifold* has the form V_g/H .

By a classical result for topological actions, $|B^2/H|$ is a disk, possibly with one singular point. Since $\text{SO}(3)$ contains only five classes of finite subgroups: the order n cyclic group C_n , the order $2n$ dihedral group D_n , the order 12 tetrahedral group T , the order 24 octahedral group O , and the order 60 icosahedral group J ,

it is easy to see B^3/H (S^2/H) belongs to one of the following five models. The underlying space $|B^3/H|$ ($|S^2/H|$) is the 3-ball (the 2-sphere).

By the equivariant Dehn lemma, see [7], it is easy to see that a handlebody orbifold is the result of gluing finitely many discal 3-orbifolds along some discal 2-orbifolds. And such gluing respecting orientations always gives us a handlebody orbifold.

Like in the manifold case we can say that an orientable separating 2-suborbifold \mathcal{F} in an orientable 3-orbifold \mathcal{O} is unknotted or knotted, depending on whether it bounds handlebody orbifolds on both sides.

It is easy to see that if the underlying space of a handlebody orbifold is a ball, then the singular set forms an unknotted tree in the ball, possibly disconnected. Unknotted means the complement of the regular neighborhood of the singular set is a handlebody. For more about handlebody orbifold theory one can see [6].

Suppose the action of G on Σ_g is extendable with respect to some embedding

$$e: \Sigma_g \hookrightarrow S^3;$$

let

$$\tilde{\Gamma} = \{x \in S^3 \mid \text{there exists } g \in G, g \neq \text{id}, \text{ s.t. } gx = x\}.$$

As locally there are only five kinds of model, $\tilde{\Gamma}$ is a graph, possibly disconnected, and S^3/G is a 3-orbifold whose singular set $\Gamma = \tilde{\Gamma}/G$ is a trivalent graph. Each edge of Γ can be labeled by an integer $n > 1$ which indicates its singular index. At each vertex the labels m, q, r of the three adjacent edges should satisfy

$$1/m + 1/q + 1/r > 1.$$

The 2-orbifold Σ_g/G maps to the 2-suborbifold $e(\Sigma_g)/G$ whose singular set $e(\Sigma_g)/G \cap \Gamma$ consists of isolated points.

We then have an orbifold covering

$$p: S^3 \longrightarrow S^3/G$$

and an orbifold embedding

$$e/G: \Sigma_g/G \hookrightarrow S^3/G.$$

Conversely, if we have an orbifold embedding from a 2-orbifold to a spherical orbifold and the preimage of the 2-suborbifold in S^3 is connected then we find an extendable action of G on some surface with respect to some embedding.

Definition 2.2. An orientable 2-suborbifold \mathcal{F} in an orientable 3-orbifold \mathcal{O} is *compressible* if either \mathcal{F} is spherical and bounds a discal 3-suborbifold in \mathcal{O} , or there is a simple closed curve in \mathcal{F} (not meeting the singular set) which bounds a discal 2-orbifold in \mathcal{O} , but does not bound a discal 2-orbifold in \mathcal{F} . Otherwise \mathcal{F} is called *incompressible*.

Lemma 2.3. Any orientable 2-suborbifold \mathcal{F} in a spherical orbifold S^3/G is compressible.

Proof. $|\mathcal{F}|$ is two sided in $|S^3/G|$. Since $\pi_1(S^3/G) = G$ is finite, $\pi_1(|S^3/G|)$ is also finite. Hence \mathcal{F} cuts S^3/G into two parts $\mathcal{O}_1, \mathcal{O}_2$, and $p^{-1}(\mathcal{F})$ cuts S^3 into several components M_1, M_2, \dots, M_k , each of which will be mapped by p to one of the two parts, the components have common boundary will be mapped to different parts.

If \mathcal{F} is spherical, $p^{-1}(\mathcal{F})$ is a disjoint union of 2-spheres. By the irreducibility of S^3 and B^3 , one M_i must be a ball, hence one \mathcal{O}_i is a discal 3-suborbifold and we have the result by definition.

Otherwise, $F = p^{-1}(\mathcal{F})$ is a disjoint union of homeomorphic closed surfaces in S^3 of genus $g \geq 1$. Since F is compressible in S^3 we can find an innermost compressing disk D . Suppose D is in M_i . By the equivariant Dehn Lemma we can find equivariant compressing disks in M_i . Suppose one of them is D' , then all the images of D' under the G action will be disjoint in S^3 . Then it gives a ‘compressing disk’ of \mathcal{F} in S^3/G . \square

Lemma 2.4. Suppose \mathcal{F} is a 2-suborbifold of a spherical orbifold S^3/G and $|\mathcal{F}|$ is homeomorphic to S^2 .

- (1) If \mathcal{F} has not more than three singular points, then \mathcal{F} is spherical and bounds a discal 3-orbifold.
- (2) If \mathcal{F} has precisely four singular points and its pre-image is connected, then \mathcal{F} bounds a handlebody orbifold in S^3/G .

Proof. As a 2-suborbifold, \mathcal{F} should be spherical or has ‘compressing disk’ by Lemma 2.3.

(1) If \mathcal{F} has no more than three singular points, every simple closed curve in \mathcal{F} bounds a discal orbifold in \mathcal{F} . So \mathcal{F} has no ‘compressing disk’ and hence is spherical, and then bounds a discal 3-orbifold.

(2) If \mathcal{F} has four singular points, \mathcal{F} is not spherical and hence has a ‘compressing disk’ D . Then ∂D separates \mathcal{F} into two discal orbifolds D_1, D_2 , each of which

contains two singular points. Now $D_1 \cup D$ and $D_2 \cup D$ are 2-suborbifolds in S^3/G each of which contains no more than three singular points; by the above argument each of them bounds a discal 3-orbifold.

There are two cases: the discal 3-orbifold bounded by $D_1 \cup D$ ($D_2 \cup D$) does not intersect the interior of D_2 (D_1). Then the two discal 3-orbifolds meet only along D , and the result is clearly a handlebody orbifold; otherwise for example the discal 3-orbifold, say V , bounded by $D_1 \cup D$ intersects the interior of D_2 .

Then D_2 is contained in V , which belongs to one of the five models in Figure 1. Then we get a handlebody orbifold with singular set contains two arcs.  \square

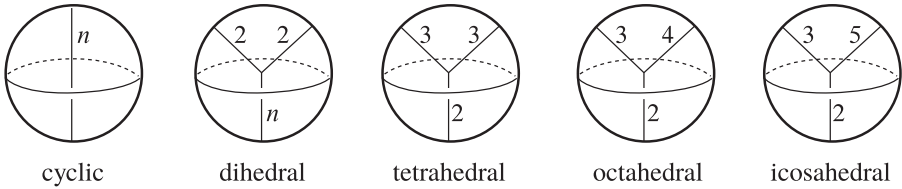

Figure 1

Proposition 2.5. *Suppose G acts on (S^3, Σ_g) . If $|G| > 4(g-1)$, then Σ_g/G has underlying space S^2 with four singular points and bounds a handlebody orbifold, and Σ_g bounds a handlebody.*

In conclusion

$$\text{OE}_g \leq \text{OH}_g \leq 12(g-1).$$

Proof. Σ_g/G is a 2-suborbifold in S^3/G whose singular set contains isolated points a_1, a_2, \dots, a_k , with indices $q_1 \leq q_2 \leq \dots \leq q_k$. Note that $|S^3/G|$ and $|\Sigma_g/G|$ are both manifolds. Suppose the genus of $|\Sigma_g/G|$ is \hat{g} . By the Riemann-Hurwitz formula

$$2 - 2g = |G| \left(2 - 2\hat{g} - \sum_{i=1}^k \left(1 - \frac{1}{q_i} \right) \right)$$

we have

$$|G| = (2g-2) / \left(\sum_{i=1}^k \left(1 - \frac{1}{q_i} \right) + 2\hat{g} - 2 \right).$$

If $\hat{g} \geq 1$ or $\hat{g} = 0, k \geq 5$, then $|G| \leq 4g-4$. Hence $\hat{g} = 0$ and $k \leq 4$. If $k \leq 3$ then Σ_g/G bounds a discal orbifold by Lemma 2.4 (1), which leads to a contradiction (since $g > 1$ by assumption). Hence $k = 4$, and by Lemma 2.4 (2) Σ_g/G bounds a handlebody orbifold. In this case Σ_g bounds a handlebody in S^3 .

By [10], or Example 7.1 in this paper,

$$\text{OE}_g \geq 4(g+1) (> 4(g-1)).$$

Hence each Σ_g in S^3 realizing OE_g must bound a handlebody, and therefore $\text{OE}_g \leq \text{OH}_g \leq 12(g-1)$. \square

Definition 2.6. Let \mathcal{F} be a 2-suborbifold in a spherical orbifold S^3/G , with $|\mathcal{F}|$ homeomorphic to S^2 and four singular points a_1, a_2, a_3, a_4 . Supposing $q_1 \leq q_2 \leq q_3 \leq q_4$ for their indices, we call (q_1, q_2, q_3, q_4) the *singular type* of \mathcal{F} .

Using the Riemann-Hurwitz formula, it is easy to see:

Lemma 2.7. *If $|G| > 4(g-1)$ then the singular type of Σ_g/G is one of*

$$(2, 2, 2, n) \quad (n \geq 3),$$

$$(2, 2, 3, 3),$$

$$(2, 2, 3, 4),$$

$$(2, 2, 3, 5).$$

Lemma 2.8. *The relation between the orders of extendable group actions and the surface genus for a given singular type is given in the following table:*

| | | | | |
|-------|---------------------------|----------------|----------------|----------------|
| Type | $(2, 2, 2, n) (n \geq 3)$ | $(2, 2, 3, 3)$ | $(2, 2, 3, 4)$ | $(2, 2, 3, 5)$ |
| Order | $4n(g-1)/(n-2)$ | $6(g-1)$ | $24(g-1)/5$ | $30(g-1)/7$ |

Lemma 2.9. *If the singular type of Σ_g/G is not $(2, 2, 3, 3)$, the handlebody orbifold bounded by Σ_g/G is as in Figure 2(a); if the singular type is $(2, 2, 3, 3)$, there are the two possibilities in Figure 2(a) and (b) for this handlebody orbifold.*

Proof. By the proof of Lemma 2.4, the handlebody orbifold bounded by Σ_g/G has underlying space B^3 and singular set a tree like in Figure 2(a) or two arcs. The indices of the end points of an arc must be the same. Hence if the singular set contains two arcs, the singular type must be $(2, 2, 3, 3)$. \square

Note that in the case of Figure 2(a) the handlebody orbifold is a regular neighborhood of a singular edge. In the case of Figure 2(b) the handlebody orbifold is a regular neighborhood of a dashed arc, and this dashed arc can be locally knotted as in the figure.

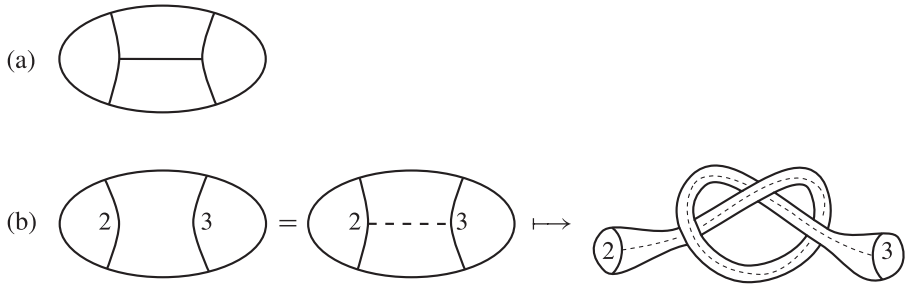

Figure 2

Lemma 2.10. *Suppose a finite group G acts on (M, F) , where M is a 3-manifold, with a surface embedding $i : F \hookrightarrow M$, so we have diagrams:*

$$\begin{array}{ccc}
 F & \xrightarrow{i} & M \\
 p \downarrow & & \downarrow p \\
 F/G & \xrightarrow{\hat{i}} & M/G
 \end{array}
 \quad
 \begin{array}{ccc}
 \pi_1(F) & \xrightarrow{i_*} & \pi_1(M) \\
 p_* \downarrow & & \downarrow p_* \\
 \pi_1(F/G) & \xrightarrow{\hat{i}_*} & \pi_1(M/G)
 \end{array}$$

Suppose F/G is connected. Then F is connected if and only if

$$\hat{i}_*(\pi_1(F/G)) \cdot p_*(\pi_1(M)) = \pi_1(M/G).$$

Proof. “ \implies ” Suppose

$$\hat{i}_*(\pi_1(F/G)) \cdot p_*(\pi_1(M)) \subsetneq \pi_1(M/G).$$

We find an orbifold covering space \hat{M} corresponds to $\hat{i}_*(\pi_1(F/G)) \cdot p_*(\pi_1(M))$. Then we have a diagram:

$$\begin{array}{ccc}
 F & \xrightarrow{i} & M \\
 p \downarrow & & \downarrow p \\
 F/G & \xrightarrow{\hat{i}} & M/G
 \end{array}
 \quad
 \begin{array}{ccc}
 & & \hat{M} \\
 & \nearrow & \searrow \\
 & & \hat{M} \\
 & \searrow & \nearrow \\
 & & \hat{M}
 \end{array}$$

Since $\hat{i}_*(\pi_1(F/G)) \subseteq \hat{p}_*(\pi_1(\hat{M}))$, F/G can lift to \hat{M} , and it lifts to a disjoint union of copies. Hence F must be disconnected.

“ \Leftarrow ” Suppose F is not connected. Let $F_1 \subsetneq F$ be a component of F and G_1 its stabilizer in G , that is

$$G_1 = \{h \in G \mid h(F_1) = F_1\}.$$

Then

$$F_1/G_1 = F/G.$$

Now

$$|\pi_1(M/G) : p_*(\pi_1(M))| = |G|,$$

and

$$\begin{aligned} & |\hat{i}_*(\pi_1(F/G)) \cdot p_*(\pi_1(M)) : p_*(\pi_1(M))| \\ &= |\hat{i}_*(\pi_1(F/G)) \cdot p_*(\pi_1(M)) / p_*(\pi_1(M))| \\ &= |\hat{i}_*(\pi_1(F/G)) / \hat{i}_*(\pi_1(F/G)) \cap p_*(\pi_1(M))| \\ &\leq |\hat{i}_*(\pi_1(F/G)) : \hat{i}_* p_*(\pi_1(F_1))| \\ &= |\pi_1(F/G) / \ker \hat{i}_* : p_*(\pi_1(F_1)) \cdot \ker \hat{i}_* / \ker \hat{i}_*| \\ &= |\pi_1(F_1/G_1) : p_*(\pi_1(F_1)) \cdot \ker \hat{i}_*| \\ &\leq |\pi_1(F_1/G_1) : p_*(\pi_1(F_1))| \\ &= |G_1| < |G|. \end{aligned}$$

Hence $\hat{i}_*(\pi_1(F/G)) \cdot p_*(\pi_1(M)) \subsetneq \pi_1(M/G)$. □

Remark 2.11. (1) When F is connected, we have

$$\hat{i}_* p_*(\pi_1(F)) = \hat{i}_*(\pi_1(F/G)) \cap p_*(\pi_1(M))$$

and

$$\ker(\hat{i}_*) \subseteq p_*(\pi_1(F)).$$

If M is simply connected, then F is connected if and only if \hat{i}_* is surjective.

(2) If $F/G \subset S^3/G$ bounds handlebody orbifolds on both sides then clearly \hat{i}_* is surjective.

Corollary 2.12. *Suppose \mathcal{F} is a connected 2-suborbifold with an embedding $\hat{i}: \mathcal{F} \hookrightarrow S^3/G$ into a spherical orbifold S^3/G . Let $p^{-1}(\mathcal{F}) = \Sigma$; then Σ is connected if and only if \hat{i}_* is surjective.*

Definition 2.13. Let (X, Γ) be an orientable 3-orbifold with underlying space X and singular set a trivalent graph Γ . An *edge killing operation* on a singular edge is defined to be a sequence of operations.

- First remove the edge (replace its label by 1).
- Then replace the labels m and n of its two adjacent edges with a common vertex by their greatest common divisor (m, n) , see Figure 3.

If $(m, n) = 1$ we continue this operation on the adjacent edges.

For example, the orbifold 23 in Table III of Section 3 has singular set a tetrahedra with three label 2 edges and three label 3 edges. If we kill a label 2 edge, we will get the orbifold 35 in Table III. If we kill a label 3 edge, then all the labels should be replaced by 1 and we get the manifold S^3 .

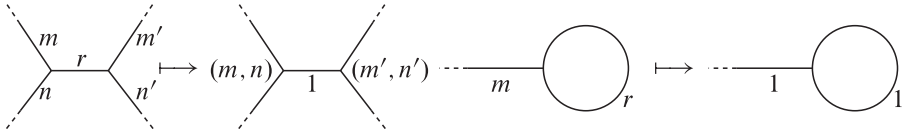

Figure 3

Lemma 2.14 (Edge killing). *Suppose (X, Γ) is an orientable 3-orbifold with underlying space X and singular set a trivalent graph Γ , and Γ' is obtained by an edge killing operation from Γ . Then we have a surjection*

$$\pi_1(X, \Gamma) \longrightarrow \pi_1(X, \Gamma').$$

Proof. Denoting by $N(\Gamma)$ a regular neighborhood of Γ in X , there is a surjective homomorphism from $\pi_1(X - N(\Gamma))$ to $\pi_1(X, \Gamma)$, and we can compute $\pi_1(X, \Gamma)$ from $\pi_1(X - N(\Gamma))$ by adding relations like $x^r = 1$ [1]. The effect of an edge killing operation on fundamental groups is just adding relations like $x = 1$, and then we obtain a presentation of $\pi_1(X, \Gamma')$. \square

Remark 2.15. This edge killing operation is just a way to get a quotient group. Using it we can show some \hat{i}_* is not surjective. The orbifold (X, Γ') may be not a good one (be covered by a manifold).

Lemma 2.16. *Let G be an extendable finite group action with respect to some embedding $e: \Sigma_g \hookrightarrow S^3$. If $|e(\Sigma_g)/G|$ is homeomorphic to S^2 , then $|S^3/G|$ is homeomorphic to S^3 .*

Proof. By Corollary 2.12 the homomorphism $(e/G)_*: \pi_1(\Sigma_g/G) \rightarrow \pi_1(S^3/G)$ is surjective. By Lemma 2.14, if we kill all the singular edges we get a surjection $\pi_1(|\Sigma_g/G|) \rightarrow \pi_1(|S^3/G|)$. Hence $\pi_1(|S^3/G|)$ is trivial and $|S^3/G|$ is homeomorphic to S^3 . \square

3. Dunbar’s list of spherical 3-orbifolds

In [3], [4] Dunbar lists all spherical orbifolds with underlying space S^3 . We list these pictures in Tables I, II, and III, and give a brief explanation such that one can check graphs conveniently. For more information, one should see the original papers.

Table I. Fibred case with base S^2 .

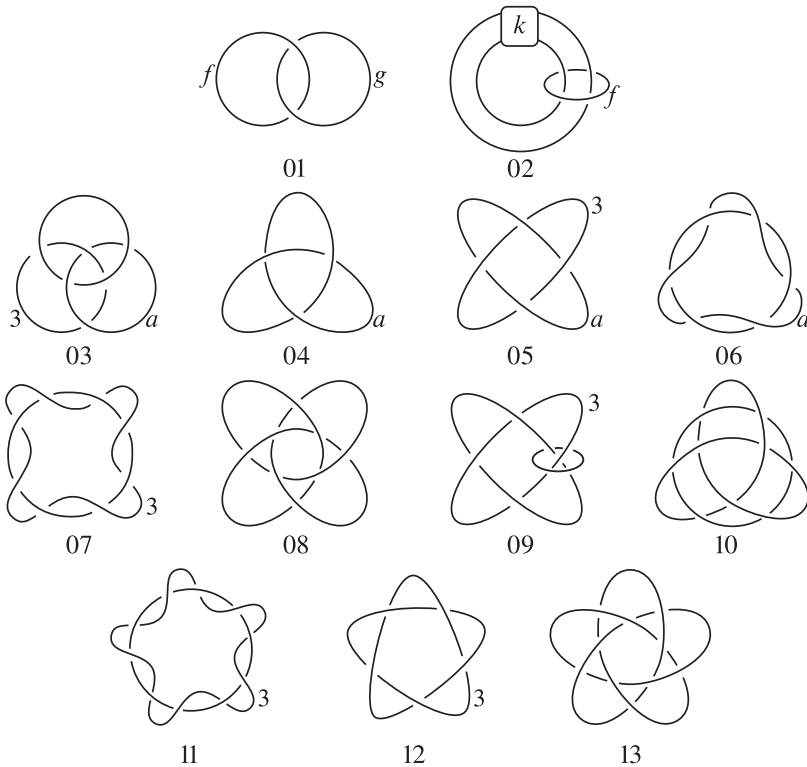
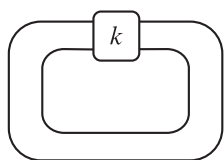
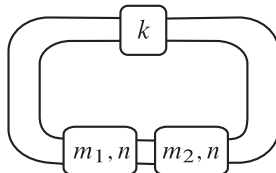

Table II. Fibred case with base D^2 .

$$k \neq 0$$

14



$$k + m_1/n + m_2/n \neq 0$$

15

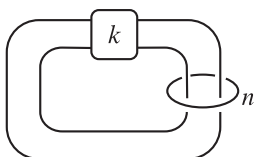

$$k \neq 0$$

16

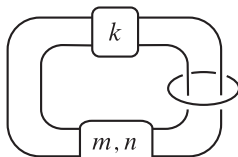

$$k + m/n \neq 0$$

17

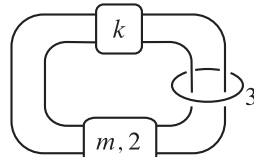

$$k + m/2 \neq 0$$

18

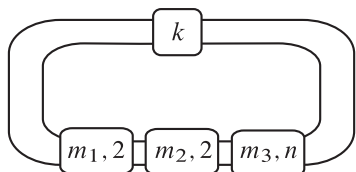

$$k + m_1/2 + m_2/2 + m_3/n \neq 0$$

19

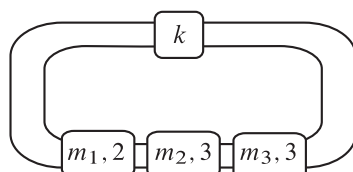

$$k + m_1/2 + m_2/3 + m_3/3 \neq 0$$

20

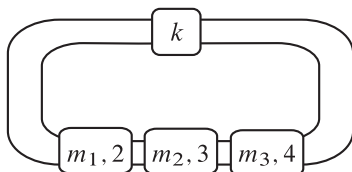

$$k + m_1/2 + m_2/3 + m_3/4 \neq 0$$

21

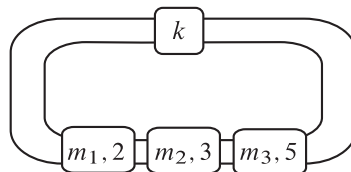

$$k + m_1/2 + m_2/2 + m_3/5 \neq 0$$

22

Table III. Non-fibred case.

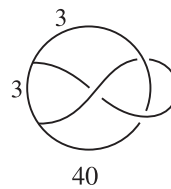
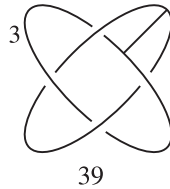
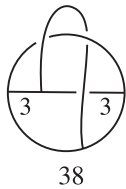
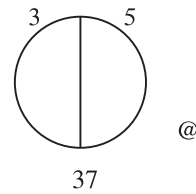
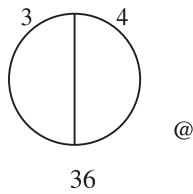
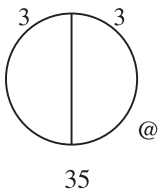
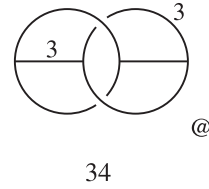
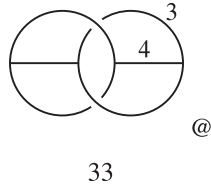
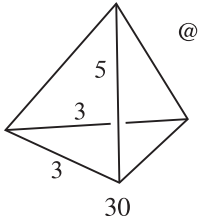
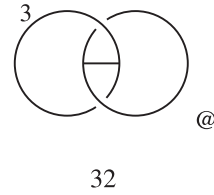
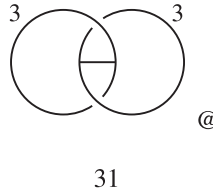
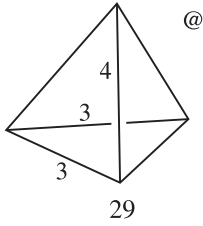
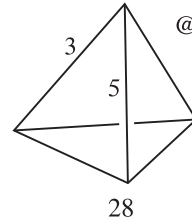
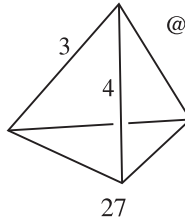
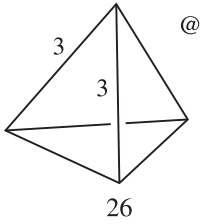
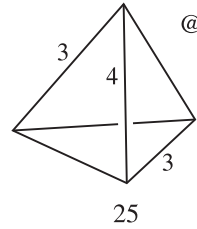
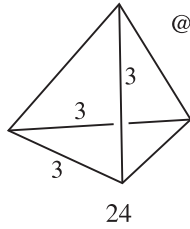
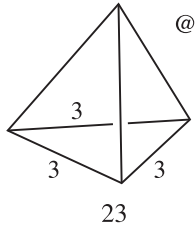

Since the underlying space is S^3 , all the information is contained in the trivalent graphs of the singular sets. Each edge in a graph is labeled by an integer indicating the singular index of the edge, with the convention that each unlabeled edge has index 2. If a graph has a vertex such that the incident edges have labels

$$(2, 3, 3), \quad (2, 3, 4), \quad (2, 3, 5),$$

the orbifold is non-fibred. All the non-fibred spherical orbifolds have underlying space S^3 and are listed in Table III. Otherwise the orbifolds are Seifert fibred and are listed in Table I (the basis of the fibration is a 2-sphere) and Table II (the basis is a disk with mirror boundary and corners).

In Table I and Table II many graphs have some free or undetermined parameters (just called *parameters* in the following). These parameters should satisfy

$$n > 1, \quad 3 \leq a \leq 5, \quad f \geq 1, \quad g \geq 1,$$

and in Table I we require

$$k \neq 0.$$

The letter ‘@’ means amphicheiral (there exists an orientation-reversing homeomorphism of the orbifold). If an orbifold is non-amphicheiral, as in the original paper its mirror image is not presented.

A box with an integer k indicates two parallel arcs with k -half twists, the over-crossings from lower left to upper right if $k > 0$, and upper left to lower right if $k < 0$. A box with two integers m, n stands for a picture as in Figure 4 and Figure 5; it satisfies

$$|2m| \leq n.$$

All the crossing numbers of the horizontal and vertical parts are determined by the unique continued fraction presentation of $|m|/n$, such that all k_i are positive and $k_i \geq 2$. All the over-crossings are from lower left to upper right if $m > 0$, and from upper left to lower right if $m < 0$. If the greatest common divisor $(|m|, n) = d > 1$, we add a ‘strut’ labeled d in the k_i twist as shown in the picture. If $m = 0$, we add a ‘strut’ labeled n between two parallel lines.

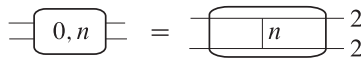
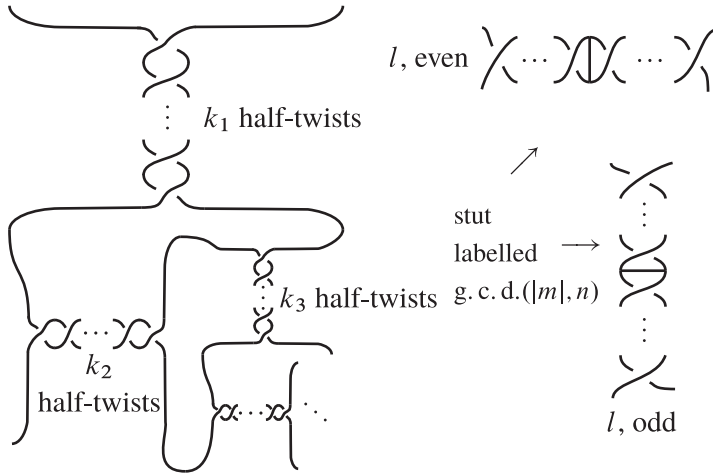

Figure 4



$$\frac{|m|}{n} = \frac{1}{k_1 + \frac{1}{k_2 + \frac{1}{\ddots + \frac{1}{k_l}}}}$$

Figure 5

4. Strategy and outline of finding OE_g

1. Obtain OE_g from allowable 2-suborbifolds in spherical 3-orbifolds. We know $OE_g \geq 4(g + 1)$ by Example 7.1, see also [10], hence to determine OE_g we can assume

$$|G| > 4(g - 1).$$

Definition 4.1. A 2-suborbifold \mathcal{F} in a spherical 3-orbifold S^3/G , with

$$|G| > 4(g - 1),$$

is called *allowable* if its preimage in S^3 is a closed connected surface Σ_g . A singular edge/dashed arc is called *allowable* if the boundary of its neighborhood is allowable.

Therefore if G acts on (S^3, Σ_g) and realizes OE_g then

$$\mathcal{F} = \Sigma_g/G \subset S^3/G$$

must be an allowable 2-suborbifold. We intend to find extendable actions from allowable 2-suborbifolds in spherical 3-orbifolds and, more weakly, to find the maximum orders of extendable actions from certain information about such allowable 2-suborbifolds.

Suppose we have a spherical 3-orbifold \mathcal{O} and an allowable 2-suborbifold $\mathcal{F} \subset \mathcal{O}$. By Proposition 2.5, \mathcal{F} has underlying space S^2 with four singular points, and moreover \mathcal{F} has a singular type as in the list of Lemma 2.7. Once we know the singular type of \mathcal{F} and the order of the orbifold fundamental group $\pi_1(\mathcal{O})$, we know the genus of the corresponding closed connected surface $\Sigma_g \subset S^3$ such that $(S^3, \Sigma_g)/G = (\mathcal{O}, \mathcal{F})$ by Lemma 2.8. So if we know the singular types of all allowable 2-orbifolds in \mathcal{O} , then we know all Σ_g which admit an extendable action of the group $G \cong \pi_1(\mathcal{O})$ with $|G| > 4(g-1)$; in other words, for a fixed g we know if Σ_g admits an extendable action of the group $G \cong \pi_1(\mathcal{O})$ with $|G| > 4(g-1)$. Hence if we know the singular types of all allowable 2-orbifolds in all spherical 3-orbifolds \mathcal{O} , then for a fixed g we know all finite groups $\pi_1(\mathcal{O}) \subset \text{SO}(4)$ such that Σ_g admits an extendable action of the group $\pi_1(\mathcal{O})$ with $|G| > 4(g-1)$, and consequently OE_g can be determined.

2. List all allowable 2-suborbifolds in spherical 3-orbifolds

Definition 4.2. A 2-sphere in a spherical 3-orbifold S^3/G is called *candidacy* if it intersects the singular graph of S^3/G in exactly four singular points of one of the types listed in Lemma 2.7.

Clearly for each allowable 2-suborbifold $\mathcal{F} \subset S^3/G$, $|\mathcal{F}| \subset |S^3/G|$ is a candidacy 2-sphere. On the other hand, each candidacy 2-sphere is the underlying space of a non-spherical 2-orbifold \mathcal{F} , and we will denote this candidacy 2-sphere by $|\mathcal{F}|$.

We say that a 2-orbifold

$$\hat{\iota}: \mathcal{F} \subset S^3/G$$

is π_1 -*surjective* if the induced map on the orbifold fundamental groups is surjective.

The process of listing all allowable 2-suborbifolds in spherical 3-orbifolds is divided into two steps.

(i) List all spherical 3-orbifolds containing allowable 2-suborbifolds.

Suppose $\hat{\iota}: \mathcal{F} \subset S^3/G$ is an allowable 2-suborbifold in a spherical 3-orbifold. Then the preimage of \mathcal{F} must be connected, and by Lemma 2.16 the underlying space of S^3/G is S^3 . All spherical 3-orbifolds with underlying space S^3 are listed in Dunbar's list provided in Section 3. Below we will denote spherical 3-orbifolds with underlying space S^3 by (S^3, Γ) , where Γ is the singular set.

Since $\hat{\iota}: \mathcal{F} \subset (S^3, \Gamma)$ is allowable, the preimage of \mathcal{F} is connected, and by Corollary 2.12, $\hat{\iota}$ is π_1 -surjective. Let (S^3, Γ) be a spherical 3-orbifold with parameters; we will show that, for each 2-suborbifold $\hat{\iota}: \mathcal{F} \hookrightarrow (S^3, \Gamma)$ such that $|\mathcal{F}|$ is a candidacy 2-sphere and $\hat{\iota}$ is π_1 -surjective, the parameters must satisfy certain equations. Then we can determine the parameters and get a list of spherical 3-orbifolds containing allowable 2-suborbifolds which is a small subset of Dunbar's list where the singular sets are relatively simple. Step (i) will be carried in Section 5.

(ii) List all allowable 2-suborbifolds in each spherical 3-orbifold obtained in Step (i).

How to find such 2-suborbifolds? Indeed this is already the question we must face in Step (i). Precisely, this question divides into two subquestions.

(a) How to find candidacy 2-spheres $|\mathcal{F}|$ in a given spherical 3-orbifold (S^3, Γ) ?

(b) For each candidacy 2-sphere $|\mathcal{F}|$ we find, how to verify if $\hat{\iota}$ is π_1 -surjective?

A simple and crucial fact in solving Question (a) is provided by Proposition 2.5. For each candidacy 2-sphere $|\mathcal{F}|$, the 2-orbifold \mathcal{F} must bound a handlebody orbifold V ; moreover the shape of V is given in Lemma 2.9.

If the singular type is not $(2, 2, 3, 3)$, then V is a regular neighborhood of a singular edge. In this case we can check all the edges to see whether the corresponding singular type is contained in the list of Lemma 2.7.

If the singular type is $(2, 2, 3, 3)$, there are two possibilities for the shape of V . The new one can be thought of as a neighborhood of a regular arc with its two ends on singular edges labeled 2 and 3 which will be presented by a dashed arc. If there is such a dashed arc then we can locally knot this arc in an arbitrary way and obtain infinitely many candidacy 2-spheres, see Figure 6; in this case we only give one such dashed arc, and this will be the unknotted one if it exists (here "unknotted" means that the boundary of a regular neighborhood of the dashed arc bounds a handlebody orbifold also on the outer side).

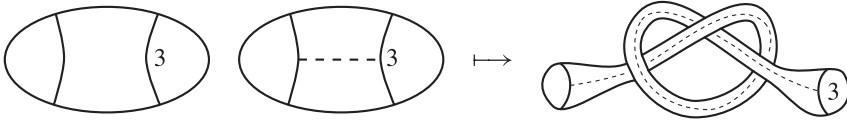

Figure 6

For Question (b), if $\mathcal{F} \subset (S^3, \Gamma)$ bounds handlebody orbifolds on both sides then \hat{i}_* is surjective (Remark 2.11 (2)). To verify the π_1 -surjectivity of $\hat{i}: \mathcal{F} \subset (S^3, \Gamma)$ for the knotted cases, we are still lucky, all π_1 -surjective cases of $\hat{i}: \mathcal{F} \subset (S^3, \Gamma)$ can be verified by the so-called *coset enumeration method*, and all non- π_1 -surjective cases can be verified by the edge killing method of Lemma 2.14, with three exceptions where Lemma 6.6 will be applied.

5. Fibred 3-orbifolds containing allowable 2-suborbifolds

Note first all graphs having parameters are contained in Table I and Table II, which are fibred 3-orbifolds.

We will establish the equations (and inequalities) which the parameters in Table I and Table II of Dunbar's list must satisfy in order to contain allowable 2-suborbifolds. We will solve these equations to get all solutions and redraw the pictures of the corresponding 3-orbifolds. Since different solutions often give the same orbifold up to the automorphisms of the orbifold, we will only draw the graphs of non-homeomorphic orbifolds.

The idea to establish those equations is as below. Suppose $\mathcal{F} \subset (S^3, \Gamma)$ is allowable. Perform suitable edge killings on Γ to get Γ' a Montesinos knot and $\pi_1(\mathcal{F}') = \mathbb{Z}_2$. Now the double branched covering N of S^3 over Γ' is a Seifert manifold, and $\pi_1(N)$ can be presented by its Seifert invariants, which are derived from those parameters of Γ . On the other hand $\mathcal{F}' \subset (S^3, \Gamma')$ is still π_1 -surjective, as suggested in the last section, which forces $\pi_1(N) = \{1\}$, and then the equations are derived. Solving those equations is an elementary but technique job.

Suppose $|\mathcal{F}| \subset |(S^3, \Gamma)|$ is a candidacy 2-sphere. Then $\mathcal{F} \subset (S^3, \Gamma)$ bounds a handlebody orbifold V of given singular type by the discussion in last section. We divide the discussion into two cases.

CASE 1. The singular type is not $(2, 2, 3, 3)$; then V is as in Figure 2(a).

CASE 2. The singular type is $(2, 2, 3, 3)$, and V is as in Figure 2(a) or as in Figure 2(b).

5.1. The discussion of Case 1. In Case 1, $\Gamma \cap V$ has two degree 3 vertices, and $\mathcal{F} = \partial V$ has singular type $(2, 2, 2, n)$, $n \geq 3$, $(2, 2, 3, 4)$ or $(2, 2, 3, 5)$. Hence $\Gamma \cap V$ must be a label 2 arc adding two ‘strut segments’ with different labels, see Figure 7; (r, s) is either $(2, n)$, or $(3, 4)$, or $(3, 5)$.

Only graphs 15, 19, 20, 21, 22 in Table II have more than one strut. So we need only to deal with these five graphs in Case 1.

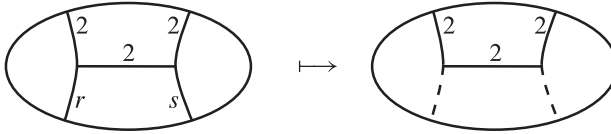

Figure 7

Suppose $\hat{i}: \mathcal{F} \subset (S^3, \Gamma)$ is π_1 -surjective. If we kill these two ‘strut segments,’ we obtain $\hat{i}: \mathcal{F}' \subset (S^3, \Gamma')$ which is also π_1 -surjective. Since $\pi_1(\mathcal{F}') = \mathbb{Z}_2$, it follows $|\pi_1(S^3, \Gamma')| \leq 2$, therefore Γ' contains no other ‘strut’ (otherwise $\pi_1((S^3, \Gamma'))$ would not be cyclic), and hence Γ' is a Montesinos link labeled by 2. The double branched cover of S^3 over Γ' must be a 3-manifold N with trivial $\pi_1(N)$ and hence $N = S^3$, that is to say Γ' is a trivial knot by the positive solution of the Smith conjecture. We use the parameters to compute $\pi_1(N)$ and then determine the parameters.

For short we present the graphs 15, 19, 20, 21, 22 by a single graph in Figure 8; the five graphs correspond to the choices $(n, n, 1)$, $(2, 2, n)$, $(2, 3, 3)$, $(2, 3, 4)$ and $(2, 3, 5)$ for (n_1, n_2, n_3) ($n > 1$). Since $|2m_i| \leq n_i$ and Γ contains exactly two ‘struts’ with different labels, we have condition

$$|2m_i| \leq n_i, \text{ at least one } m_i \text{ is zero and at least one } m_i \text{ is nonzero.} \quad (*)$$

Let $(|m_i|, n_i) = d_i$ be the greatest common divisor of $|m_i|$ and n_i , by the singular type restrictions we have

$$\{d_1, d_2, d_3\} = \{1, 2, d\}, (d > 2), \text{ or } \{1, 3, 4\} \text{ or } \{1, 3, 5\}. \quad (**)$$

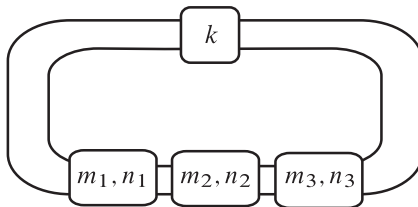

Figure 8

Write $m_i = m'_i d_i$, $n_i = n'_i d_i$, then Γ' is the Montesinos link presented by Figure 8, with each (m_i, n_i) replaced by (m'_i, n'_i) . By a theorem of Montesinos [2, Proposition 12.30], the double branched cover of S^3 over Γ' is a Seifert manifold N whose fundamental group has the following presentation:

$$\begin{aligned} \pi_1(N) = \langle x, y, z, t \mid & x^{n'_1} t^{m'_1} = y^{n'_2} t^{m'_2} = z^{n'_3} t^{m'_3} = 1, \\ & x y z t^{-k} = 1, \\ & [x, t] = [y, t] = [z, t] = 1 \rangle. \end{aligned}$$

If $m_i = 0$ for some i , then $n'_i = 1$ by definition, and it is easy to see $\pi_1(N)$ is an abelian group. Now $\pi_1(N)$ is trivial if and only if the determinant of the presentation matrix is ± 1 . Hence we have

$$k n'_1 n'_2 n'_3 + m'_1 n'_2 n'_3 + n'_1 m'_2 n'_3 + n'_1 n'_2 m'_3 = 1, \quad (1)$$

or

$$k n'_1 n'_2 n'_3 + m'_1 n'_2 n'_3 + n'_1 m'_2 n'_3 + n'_1 n'_2 m'_3 = -1. \quad (1')$$

Dividing $n'_1 n'_2 n'_3$ on both sides and using the facts that $|2m'_i| \leq n'_i$ and $m'_i = 0$ for some i , we have

$$|k| \leq 1/n'_1 n'_2 n'_3 + |m'_1|/n'_1 + |m'_2|/n'_2 + |m'_3|/n'_3 < 2$$

and then $k = 0, \pm 1$.

Noticing that solutions of (1) and (1)' have a one to one correspondence if we change the signs of k and m'_i simultaneously. And the corresponding knot of one solution is the mirror image of the other. Hence we need only deal with (1).

In (1) since $|2m'_i| \leq n'_i$ and one m'_i is zero, k can not be -1 . For example assume $m'_1 = 0$ and $k = -1$, then $n'_1 = 1$ and (1) becomes

$$-n'_2 n'_3 + m'_2 n'_3 + n'_2 m'_3 = 1.$$

But since $|2m'_i| \leq n'_i$,

$$-2n'_2 n'_3 + 2m'_2 n'_3 + 2n'_2 m'_3 \leq -2n'_2 n'_3 + n'_2 n'_3 + n'_2 n'_3 = 0.$$

Now for a given choice of (n_1, n_2, n_3) , we will find all possible solutions (k, m_1, m_2, m_3) or (k, m_1, m_2, m_3, n) satisfying (*), (**), (1) or (1)'. Changing signs of a solution will give us a mirror image. Moreover a picture of a solution with $k = 1$ always isomorphic to a picture of solution with $k = 0$ (an illustration is given in Figure 10, the illustrations of remaining cases are similar). We only draw the graphs of the non-homeomorphic orbifolds. We further divide the discussion into three subcases.

(i) **Solutions for $(n_1, n_2, n_3) = (2, 3, 3), (2, 3, 4), (2, 3, 5)$.** It is easy to get those solutions directly.

If $(n_1, n_2, n_3) = (2, 3, 3)$, then

$$(k, m_1, m_2, m_3) = (0, 0, \pm 1, 0),$$

$$(0, 0, 0, \pm 1).$$

We present the picture for the case of $(0, 0, 0, 1)$.

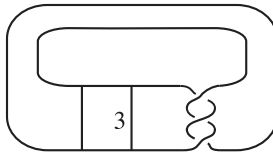

Figure 9

If $(n_1, n_2, n_3) = (2, 3, 4)$ then

$$(k, m_1, m_2, m_3) = (0, 0, 0, \pm 1),$$

$$(0, 0, \pm 1, 0),$$

$$(0, \pm 1, 0, 0),$$

$$(\pm 1, \mp 1, 0, 0).$$

We present $(0, 0, 0, 1), (0, 0, 1, 0), (0, 1, 0, 0)$ and $(1, 1, 0, 0)$. It is clear the last two pictures are homeomorphic.

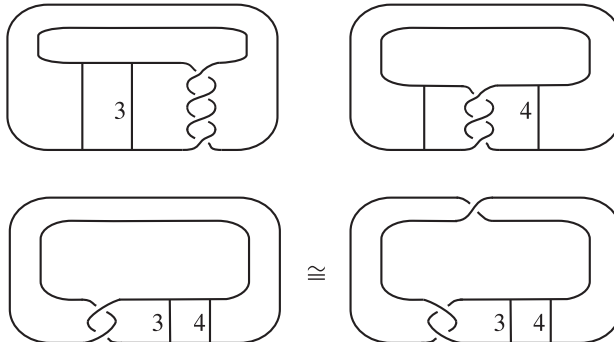

Figure 10

If $(n_1, n_2, n_3) = (2, 3, 5)$ then

$$\begin{aligned} (k, m_1, m_2, m_3) &= (0, 0, 0, \pm 1), \\ &(0, 0, \pm 1, 0), \\ &(0, \pm 1, 0, 0), \\ &(\pm 1, \mp 1, 0, 0). \end{aligned}$$

We present $(0, 0, 0, 1)$, $(0, 0, 1, 0)$ and $(0, 1, 0, 0)$.

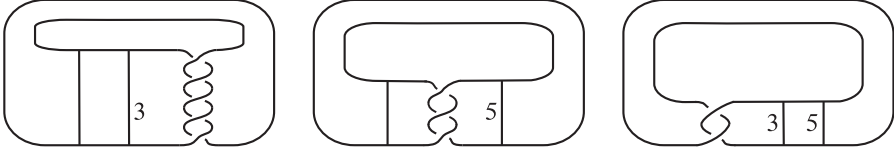

Figure 11

(ii) Solution for $(n_1, n_2, n_3) = (2, 2, n)$. Since m_1 and m_2 are symmetry, by (*) and (**) we can assume $|m_1| = 1$ and $m_2 = 0$. Then $n'_1 = 2, n'_2 = 1, m'_1 = m_1, m'_2 = 0, d_1 = 1, d_2 = 2$. (1) becomes to

$$2kn'_3 + m_1n'_3 + 2m'_3 = 1. \quad (2)$$

If $k = 0$, by (*) we have $m_1 = 1, n'_3 = 1 - 2m'_3$. Let $m = |m'_3|, d = d_3$. We have

$$(k, m_1, m_2, m_3, n) = (0, 1, 0, -md, (1 + 2m)d),$$

hence also

$$(k, m_1, m_2, m_3, n) = (0, -1, 0, md, (1 + 2m)d).$$

If $k = 1$, by (*) we have $m_1 = -1, n'_3 = 1 - 2m'_3$. Let $m = |m'_3|, d = d_3$. We have

$$(k, m_1, m_2, m_3, n) = (1, -1, 0, -md, (1 + 2m)d),$$

hence also

$$(k, m_1, m_2, m_3, n) = (-1, 1, 0, md, (1 + 2m)d).$$

Hence by symmetry and signs changing we have all the solutions:

$$\begin{aligned} (k, m_1, m_2, m_3, n) &= (0, \pm 1, 0, \mp md, (1 + 2m)d), \\ &(\pm 1, \mp 1, 0, \mp md, (1 + 2m)d), \\ &(0, 0, \pm 1, \mp md, (1 + 2m)d), \\ &(\pm 1, 0, \mp 1, \mp md, (1 + 2m)d), \end{aligned}$$

with $n > 1$. We present $(0, 1, 0, -md, (1 + 2m)d)$, $m \neq 0$, and $(0, 1, 0, 0, n)$.

Denote by \mathcal{O} the orbifold presented by the left graph in Figure 12. If we kill the edge which is labeled by d , we obtain an orbifold which is fibred over $D^2(2, 2, 1 + 2m)$ with $1 + 2m \geq 3$ [3] (the 2-orbifold with base D^2 and three corner points with labels $(2, 2, 1 + 2m)$). Then after killing the element presenting the fiber, we obtain a surjection

$$\pi_1(\mathcal{O}) \longrightarrow \pi_1(D^2(2, 2, 1 + 2m)).$$

The latter group is non-abelian. But the fundamental group of our 2-suborbifold, if it exists, would be $\mathbb{Z}_2 \times \mathbb{Z}_2$ after killing; this means that we cannot find an allowable 2-suborbifold in \mathcal{O} .

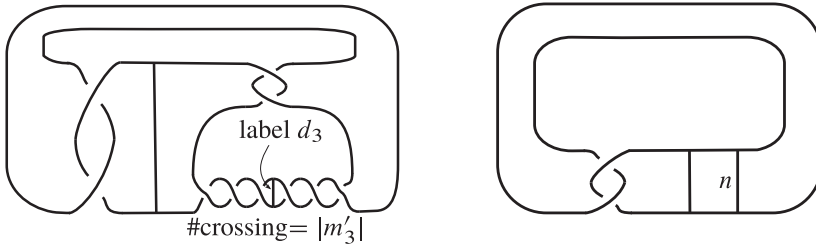

Figure 12

(iii) Solution for $(n_1, n_2, n_3) = (n, n, 1)$. Now let $n'_3 = n_3 = 1, m'_3 = m_3 = 0$, and $d_3 = 1$. (1) becomes

$$k n'_1 n'_2 + n'_1 m'_2 + n'_2 m'_1 = 1. \quad (3)$$

If $k = 0$, we have

$$n m_2 + n m_1 = d_1 d_2. \quad (4)$$

By (**), $\{d_1, d_2\} = \{2, d\}$ ($d > 2$), $\{3, 4\}$ or $\{3, 5\}$. By symmetry we can assume $d_1 < d_2$.

When $d_1 = 2, d_2 = d > 2$, by (4) we have $n = d$ or $n = 2d$.

If $n = d$, then $n'_2 = 1, m_2 = m'_2 = 0$, hence by (4) we have $m_1 = 2$ and $n = d$ is an even number $2n'$, here $n' = n'_1 > 1$. We have

$$(k, m_1, m_2, n) = (0, 2, 0, 2n'), \quad n' > 1.$$

If $n = 2d$, then $n'_2 = 2, |m'_2| = 1$, hence by (3) we have $m'_2 = 1, m_2 = d, d = n'_1 = 1 - 2m'_1$. Let $m = |m'_1|$, we have

$$(k, m_1, m_2, n) = (0, -2m, 1 + 2m, 2(1 + 2m)), \quad m > 0.$$

When $\{d_1, d_2\} = \{3, 4\}$ or $\{3, 5\}$, by a similar way one can get

$$(k, m_1, m_2, n) = (0, -3, 4, 12),$$

$$(0, 6, -5, 15).$$

If $k = 1$, by (3) and (*) we have

$$2 = n'_1(n'_2 + 2m'_2) + n'_2(n'_1 + 2m'_1) \geq 0.$$

If none of $(n'_i + 2m'_i)(i = 1, 2)$ is zero, then $n'_1 = n'_2 = 1$ and $d_1 = d_2$ which is a contradiction. By symmetry we can assume $n'_1 + 2m'_1 = 0$, then we have $n'_1 > 1$ and $n'_1(n'_2 + 2m'_2) = 2$. Hence we have $n'_1 = 2, m'_1 = -1$ and $n'_2 = 1 - 2m'_2$. By (**) if we let $m = |m'_2|$, we have

$$(k, m_1, m_2, n) = (1, -2, 0, 4)$$

or

$$(1, -1 - 2m, -2m, 2(1 + 2m))(m > 0).$$

By symmetry and signs changing we list all the solutions when $(n_1, n_2, n_3) = (n, n, 1)$.

First the solutions we get above adding signs changing solutions:

$$(k, m_1, m_2, n) = (0, \pm 2, 0, 2n'),$$

$$(0, \pm 2m, \mp(1 + 2m), 2(1 + 2m)),$$

$$(0, \pm 3, \mp 4, 12),$$

$$(0, \pm 6, \mp 5, 15),$$

$$(\pm 1, \mp 2, 0, 4),$$

$$(\pm 1, \mp(1 + 2m), \mp 2m, 2(1 + 2m)).$$

Then the symmetry solutions:

$$(k, m_1, m_2, n) = (0, 0, \pm 2, 2n'),$$

$$(0, \mp(1 + 2m), \pm 2m, 2(1 + 2m)),$$

$$(0, \pm 4, \mp 3, 12),$$

$$(0, \pm 5, \mp 6, 15),$$

$$(\pm 1, 0, \mp 2, 4)$$

$$(\pm 1, \mp 2m, \mp(1 + 2m), 2(1 + 2m)).$$

Here the parameters satisfies $n' > 1, m > 0$. Symmetry solutions give us the same picture, signs changing solutions give us the mirror picture, and a solution with $k = 1$ always has the same picture of a solution with $k = 0$. We present

$$(0, -1 - 2m, 2m, 2 + 4m) \quad (m > 0),$$

$$(0, 0, 2, 2n') \quad (n' > 1),$$

$$(0, 4, -3, 12),$$

$$(0, 5, -6, 15).$$

Note that each of the corresponding graphs is isotopic to a simple one as indicated in Figure 13.

This finishes the discussion for Case 1.

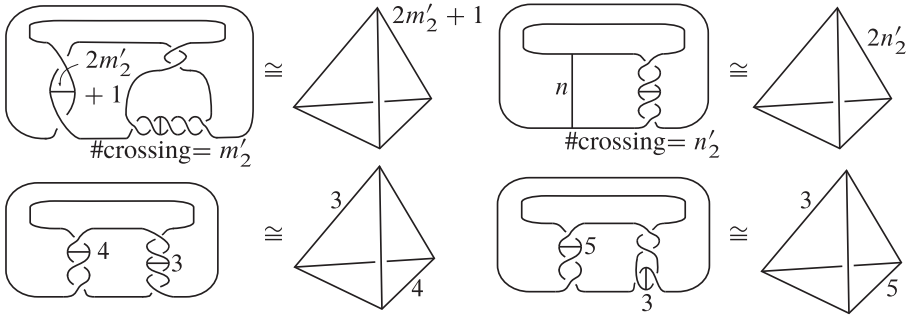

Figure 13

5.2. The discussion of Case 2. For Case 2, by the same discussion as in Case 1, the graphs we find have the property that if we kill the label 3 ‘struts’ or a label 3 singular edge, then we get a trivial knot labeled by 2.

By this property, the link cases (no vertices or struts), including Table I now and also the graphs 14 and 16 in Table II, are easy to handle. Graphs 04, 08, 10, 12, 13 and 14 are ruled out since each of them has only one index. Graphs 03 and 09 are ruled out since after killing an index 3 component (intersecting V), the remaining is not a trivial knot.

In Table II, there are two further graphs which possibly contain exactly one ‘strut,’ the graphs 17 and 18. Now 17 is ruled out since after killing the possible index 3 ‘strut’ (intersecting V), the remaining is not a trivial knot. Concerning 18, the only possible graph is the link on the upper right hand side of Figure 14 which presents all possible labeled links; the graph on the lower left hand side come from 02, 05 and 16, and the the remaining four graphs are come from 01, 06, 07 and 11.

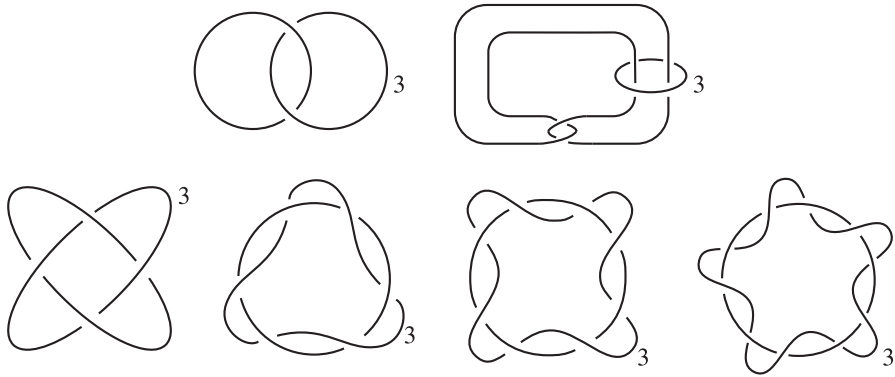

Figure 14

Concerning the possible ‘strut’ cases, we still have to consider the five graphs discussed in Case 1, but the case here is much simpler since the possible ‘strut’ can only label 3. We list the solutions and pictures below as in Case 1. Since most of the solutions present the same graph or a mirror image we only picture the graphs of non-homeomorphic orbifolds.

If $(n_1, n_2, n_3) = (2, 3, 3)$ then

$$\begin{aligned}
 (k, m_1, m_2, m_3) &= (0, \pm 1, 0, 0), \\
 &(\pm 1, \mp 1, 0, 0), \\
 &(\pm 1, \mp 1, 0, \mp 1), \\
 &(0, \pm 1, 0, \mp 1), \\
 &(\pm 1, \mp 1, \mp 1, 0), \\
 &(0, \pm 1, \mp 1, 0).
 \end{aligned}$$

We present $(0, 1, 0, 0)$ and $(0, -1, 0, 1)$.

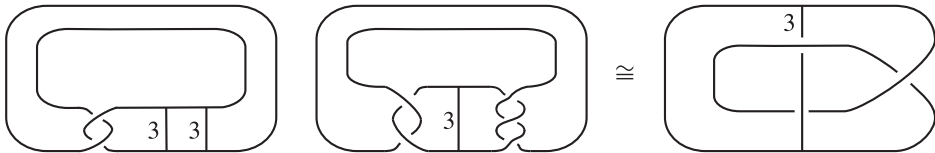

Figure 15

If $(n_1, n_2, n_3) = (2, 3, 4)$, there is no solution.

If $(n_1, n_2, n_3) = (2, 3, 5)$ then

$$(k, m_1, m_2, m_3) = (\pm 1, \mp 1, 0, \mp 2),$$

$$(0, \pm 1, 0, \mp 2).$$

We picture $(0, -1, 0, 2)$.

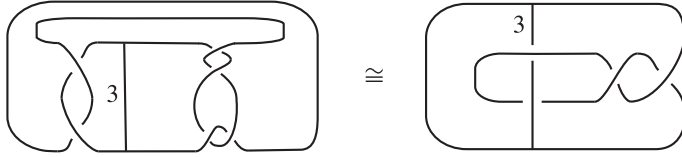

Figure 16

If $(n_1, n_2, n_3) = (2, 2, n)$, there is no solution.

Notice that when $(n_1, n_2, n_3) = (n, n, 1)$, we must have $\{d_1, d_2\} = \{1, 3\}$ or $\{3, 3\}$. By a similar way as above we have

$$(k, m_1, m_2, n) = (\pm 1, 0, 0, 3),$$

$$(0, \pm 1, 0, 3),$$

$$(0, 0, \pm 1, 3).$$

We picture $(1, 0, 0, 3)$ and $(0, 0, 1, 3)$.

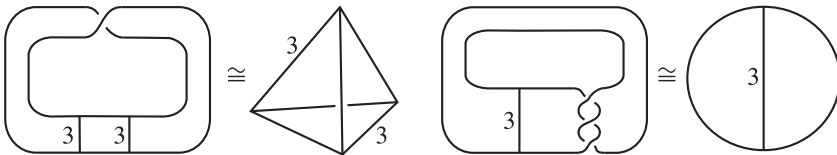

Figure 17

This finishes also the possible ‘strut’ cases. And we finished the discussion of Case 2.

Concluding, we have found all spherical fibred 3-orbifolds in which an allowable 2-suborbifold might exist. Up to automorphism of orbifolds, they are pictured in Figures 9–17, except the left one in Figure 12. Those fibred 3-orbifolds and the 3-orbifolds in Table III (non-fibred case) provides the list in the next section (note that the first two orbifolds in Figure 13 are recorded as the orbifold 15E in Table V).

6. List of allowable 2-suborbifolds

In this section our main result Theorem 6.1 will be presented and proved. We are going to give some explanations and conventions before we state Theorem 6.1.

From now on, an edge always means an edge of Γ , the singular set of the orbifold; and a dashed arc is always a regular arc with two ends at two edges of indices 2 and 3.

The primary part of Theorem 6.1 is the list of spherical 3-orbifolds which have survived after the discussion in Section 5. For each 3-orbifold in the list, we first give the order of its fundamental group. Then we use edges and dashed arcs marked by letters a, b, c, \dots , to denote the allowable 2-suborbifolds which are the boundaries of regular neighborhoods of these edges and arcs. Next we write down the singular type of these allowable 2-suborbifold, followed by the corresponding genus which can be computed by Lemma 2.8. When the singular type is $(2, 2, 3, 3)$, there are two types denoted by I and II, corresponding to Figure 2(a) and Figure 2(b), respectively. If the 2-suborbifold is a knotted one we give a foot notation ' k ' to this edge or dashed arc. In the type II cases, if a dashed arc can be chosen as an unknotted one then it can also be chosen as a knotted one, and we add a foot notation ' uk ' to this arc. We first list the fibred cases of type I and II, then the fibred cases not of type $(2, 2, 3, 3)$, and finally the non-fibred cases.

Theorem 6.1. *The following table lists all allowable singular edges/dashed arcs except those of type II. In the type II case, if there exists an allowable dashed arc we give just one such dashed arc, and this will be unknotted if there exists an unknotted one.*

Remark 6.2. From the list it is easy to see when $g = 21$ or $g = 481$ the maximal order can only be realized by a knotted embedding. The orbifolds corresponding to these situations are 28, 34 and 38.

Table IV. Fibred case: type is $(2, 2, 3, 3)$.





| | |
|--|---|
|  <p>01</p> <p>$G = 6$ $a_{uk}: \text{II}, g = 2$</p> |  <p>02 or 05 or 16</p> <p>$G = 18$ $a_{uk}: \text{II}, g = 4$</p> |
|  <p>06</p> <p>$G = 48$ $a_{uk}: \text{II}, g = 9$</p> |  <p>07</p> <p>$G = 144$ $a_{uk}: \text{II}, g = 25$</p> |
|  <p>11</p> <p>$G = 720$ $a_{uk}: \text{II}, g = 121$</p> |  <p>15A</p> <p>$G = 6$ $a: \text{I}, g = 2$ $b_{uk}: \text{II}, g = 2$</p> |
|  <p>15B</p> <p>$G = 18$ $a: \text{I}, g = 4$</p> |  <p>20A</p> <p>$G = 144$ $a: \text{I}, g = 25$</p> |
|  <p>20B</p> <p>$G = 48$ $a: \text{I}, g = 9$ $b_{uk}: \text{II}, g = 9$ $c_k: \text{I}, g = 9$</p> |  <p>22A</p> <p>$G = 720$ $a: \text{I}, g = 121$ $b_{uk}: \text{II}, g = 121$ $c_k: \text{I}, g = 121$</p> |
|  <p>18</p> <p>$G = 144$ $a_{uk}: \text{II}, g = 25$</p> | |

Table V. Fibred case: type is not $(2, 2, 3, 3)$.

$$|G| = 24$$

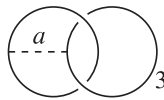
$$a:(2,2,3,4), g = 6$$

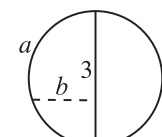
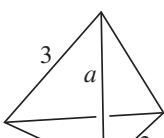
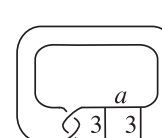
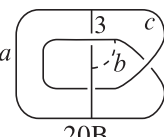
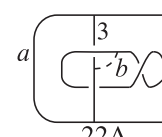
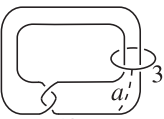
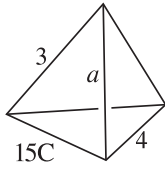
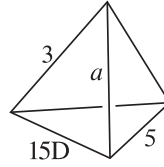

$$|G| = 30$$

$$a:(2,2,3,5), g = 8$$

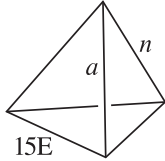

$$|G| = 4n$$

$$a:(2,2,2,n)$$

$$g = n - 1$$

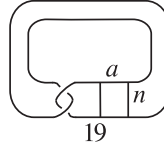

$$|G| = 4n^2$$

$$a:(2,2,2,n)$$

$$g = (n - 1)^2$$

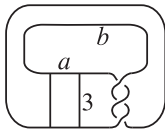

$$|G| = 96$$

$$a:(2,2,2,3), g = 9$$

$$b_k:(2,2,2,3), g = 9$$

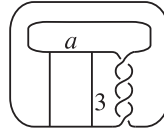

$$|G| = 288$$

$$a:(2,2,2,3), g = 25$$

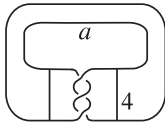

$$|G| = 384$$

$$a:(2,2,2,4), g = 49$$

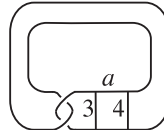

$$|G| = 576$$

$$a:(2,2,3,4), g = 121$$

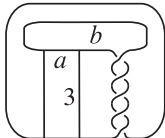

$$|G| = 1440$$

$$a:(2,2,2,3), g = 121$$

$$b_k:(2,2,2,3), g = 121$$

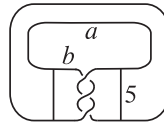

$$|G| = 2400$$

$$a:(2,2,2,5), g = 361$$

$$b_k:(2,2,2,5), g = 361$$

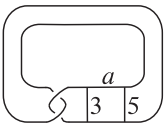

$$|G| = 3600$$

$$a:(2,2,3,5), g = 841$$

22D

Table VI. Non-fibred case (first part).

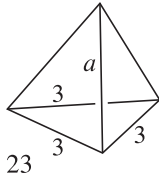

$|G| = 96$
 $a: \text{I}, g = 17$

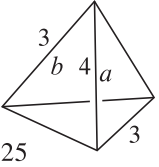

$|G| = 576$
 $a: \text{I}, g = 97$
 $b: (2,2,2,4), g = 73$

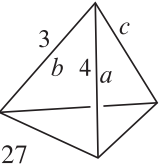

$|G| = 48$
 $a: (2,2,2,3), g = 5$
 $b: (2,2,2,4), g = 7$
 $c: (2,2,3,4), g = 11$

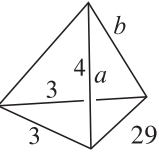

$|G| = 192$
 $a: (2,2,2,3), g = 17$
 $b: (2,2,3,4), g = 41$

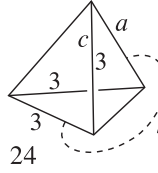

$|G| = 60$
 $a: \text{I}, g = 11$
 $b_k: \text{II}, g = 11$
 $c: (2,2,2,3), g = 6$

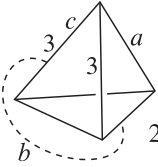

$|G| = 24$
 $a: \text{I}, g = 5$
 $b_k: \text{II}, g = 5$
 $26 c: (2,2,2,3), g = 3$

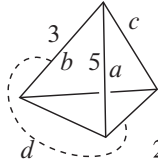

$|G| = 120$
 $a: (2,2,2,3), g = 11$
 $b: (2,2,2,5), g = 19$
 $c: (2,2,3,5), g = 29$
 $d_k: \text{II}, g = 21$

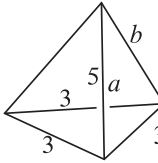

$|G| = 7200$
 $a: (2,2,2,3), g = 601$
 $b: (2,2,3,5), g = 1681$

Table VI. Non-fibred case (second part).

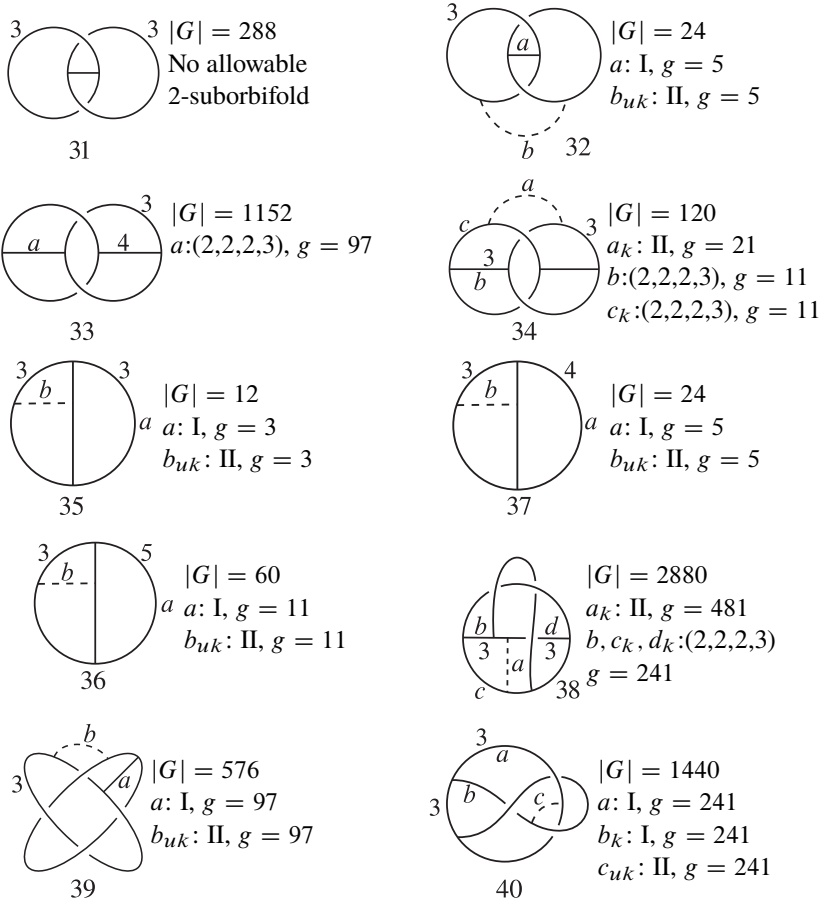

Proof. One can easily check that the list of 3-orbifolds in Theorem 6.1 contains exactly those in Tables I and II which survive after Section 5, and those in Table III. By the discussion of Section 5, all allowable 2-orbifolds are contained in one of these 3-orbifolds.

There are two infinity sequences of 3-orbifolds, 15E and 19 in the above list. For these two sequences, we know the group actions on the pair (S^3, Σ_g) clearly, see Examples 7.1 and 7.2 in Section 7. The other orders of the fundamental groups can be calculated directly from their Wirtinger presentations of these graphs and by using [13], see Example 6.3 for details. And for the non-fibred case, the group order can also be got from the group structure, see [4].

To finish the proof of Theorem 6.1, we still need to answer questions below.

- I. Why do those marked edges and the dashed arcs give allowable 2-suborbifolds?
- II. Why do those marked edges and the dashed arcs give all allowable 2-suborbifolds (up to some equivalences)?

Concerning I, by direct inspections each marked edge and each dashed arc gives a candidacy 2-sphere $|\mathcal{F}|$ (see Definition 4.1). One can easily check that all standard edges and dashed arcs (without subscript k) give rise to unknotted 2-suborbifolds, and then the surjection condition is automatically satisfied (Remark 2.11). So one has to check only edges and dashed arcs which exist only in a knotted version (i.e. with the subscript ' k ').

There are 9 knotted marked edges which are c in 20B, 22A, 34, 38; b in 20C, 22B, 22C, 38, 40; and 5 knotted dashed arcs which are b in 24, 26; d in 28; a in 34, 38. The verification of the surjectivity in these 14 cases is based on the so-called *coset enumeration method* ([8], p. 351, Chapter 11).

To answer Question II, we divide the discussion into two cases.

CASE 1. If an edge is not marked, then either

- (i) the corresponding 2-suborbifold is not a candidacy 2-sphere, or
- (ii) the corresponding 2-suborbifold can be mapped to a marked edge by an index preserving automorphism of (S^3, Γ) , or
- (iii) the inclusion of $\mathcal{F} \subset (S^3, \Gamma)$ is not π_1 -surjective.

CASE 2. If there is no dashed arc in a 3-orbifold (S^3, Γ) in the list, then for any dashed arc in (S^3, Γ) giving a candidacy 2-sphere the corresponding 2-suborbifold $\mathcal{F} \subset (S^3, \Gamma)$ is not π_1 -surjective.

The verification of Case 1 (i) and (ii) is just by a direct inspection. The verification of Case 1 (iii) and Case 2 will use Edge killing method (Lemma 2.14) and Lemma 6.6 below. \square

Now we would like to prove three examples in detail. All the other cases can be proved by the same arguments.

Example 6.3. This is the orbifold 34 in the above list. We use this example to explain two things: 1. How do we get the group order? 2. How do we find all allowable singular edges and dashed arcs in such a 3-orbifold?

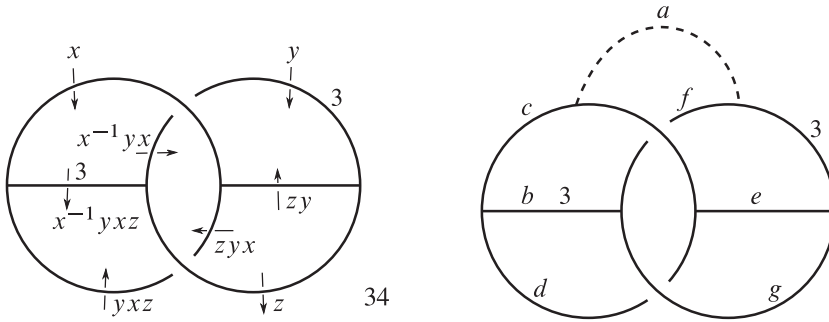

Figure 18

Denote the corresponding 3-orbifold by \mathcal{O} . From Figure 18 we obtain the following presentation of the orbifold fundamental group of \mathcal{O} :

$$\pi_1(\mathcal{O}) = \langle x, y, z \mid x^2 = y^3 = z^2 = 1, (zy)^2 = (y_xz)^2 = (y_xz_x)^3 = 1 \rangle$$

We input these generators and relations into [13], and the computer uses the standard procedure (called *coset enumeration*) to show the group order is 120.

Then there are 6 singular edges in this orbifold, b, c, d, e, f, g . For each we should consider if it is allowable. First, b and e are unknotted, because the boundary of their neighborhoods are isotopic, so the corresponding 2-orbifold bounds handlebody orbifolds on both sides. And for an unknotted 2-suborbifold, its fundamental group naturally surjectively mapped into $\pi_1(\mathcal{O})$. So b and e are allowable. But since they give the same 2-orbifold, we only label b here. For c , its fundamental group is generated by

$$\pi_1(\mathcal{F}_c) = \langle y_xz, x, zy \rangle$$

also by [13], the computer can show that $[\pi_1(\mathcal{O}) : \pi_1(\mathcal{F}_c)] = 1$, so c is allowable. We can see there is an automorphism of \mathcal{O} which changes c and d , so d is also allowable and we only label c in the list. Furthermore, the boundary of the neighborhood of c is not the boundary of the neighborhood of another singular edge, so we get c_k . The type of g is $(2, 3, 3, 3)$, which is not in the list of Lemma 2.7, so g is not allowable. f is also not allowable since $[\pi_1(\mathcal{O}) : \pi_1(\mathcal{F}_f)] > 1$ (this can be verified by either coset enumeration method or edge killing method).

Now we consider dashed arcs in this orbifold. As in the figure, we choose a dashed arc a , its fundamental group is generated by

$$\pi_1(\mathcal{F}_a) = \langle x, y \rangle$$

also by [13], the computer can show that $[\pi_1(O) : \pi_1(\mathcal{F}_a)] = 1$, so a is allowable. So we already find an allowable dashed arc. Then since different dashed arcs will give surfaces with the same genus, we don't need to find more dashed arcs. And in this orbifold, out of the neighborhood of each dashed arc there must be 4 singular edges, it can not be a handlebody orbifold, so each allowable dashed arc must be knotted. So we have a_k .

Example 6.4. This orbifold is labeled with number 33 in the above list. We use this example to explain: how do we proof a 3-orbifold contains no allowable dashed arc?

If there is an allowable dashed arc corresponding to an allowable 2-orbifold \mathcal{F} , then one end of the dashed arc must lay on the edge e labeled 3. Kill the edge e , then $\pi_1(\mathcal{F}) = \mathbb{Z}_2$, but $\pi_1(S^3, \Gamma') = \mathbb{Z}_2 \oplus \mathbb{Z}_2$. Hence the dashed arc can not be allowable. There is no allowable dashed arc at all.

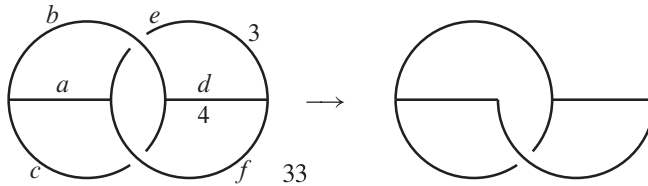

Figure 19

Example 6.5. There are three orbifolds 23, 29, 30 for which by the edge killing method we do not get the non- π_1 -surjectivity of the inclusion corresponding to the dashed arcs. We use Lemma 6.6 to deal with these three cases.

Lemma 6.6. *Let S be one of the permutation groups A_4, S_4, A_5 . Let H be a subgroup of $S \times S$ such that the restrictions to H of the two canonical projections of $S \times S$ to S are both surjective. If H is not isomorphic to S then an order 2 element and an order 3 element in H cannot generate H .*

Proof. Let (x, x') and (y, y') be order 2 and order 3 elements in H which generate H . Since the two projections restricted to H are surjective, both x and x' have order 2, and both y and y' have order 3; moreover the subgroups generated by x, y and also by x', y' are both equal to S . One can check now by explicit computations in each of the three groups that the map $x \mapsto x', y \mapsto y'$ gives an isomorphism of S to itself. Hence H is isomorphic to S . \square

Notice that $T \cong A_4, O \cong S_4, J \cong A_5$. We will use this lemma to some finite groups, with form $S \times S$, in $\text{SO}(3) \times \text{SO}(3)$ which is 2-sheet covered by $\text{SO}(4)$.

In 23, 29 and 30 the fundamental groups of these orbifolds are the finite groups

$$\mathbf{T} \times_{C_3} \mathbf{T}, \quad \mathbf{O} \times_{D_3} \mathbf{O}, \quad \mathbf{J} \times \mathbf{J}$$

of $\text{SO}(4)$, see [4] for the notations. They can map surjectively to $T \times_{C_3} T, O \times_{D_3} O, J \times J$ under the 2 to 1 map $\text{SO}(4) \rightarrow \text{SO}(3) \times \text{SO}(3)$. For an allowable dashed arc, the fundamental group of a regular neighborhood is generated by an order 2 element and an order 3 element. But by Lemma 6.6, any two such elements in the groups $T \times_{C_3} T, O \times_{D_3} O, J \times J$ cannot generate the whole group.

Now we prove our main results.

Theorem 1.4 follows from Theorem 6.1; Theorem 1.1 and Theorem 1.2 follow from Theorem 1.4, with some elementary arithmetic.

Note that $4n(g-1)/(n-2)$ will be $12(g-1)$ when $n=3$ and $8(g-1)$ when $n=4$; also, $4n(g-1)/(n-2)$ will be $4(\sqrt{g}+1)^2$ when $g=(n-1)^2$ and $4(g+1)$ when $g=n-1$.

Only the last two rows of the tables in Theorems 1.1 contain infinitely many genera, corresponding to the orbifolds 15E and 19 in Theorem 6.1.

To derive Theorem 1.3 we notice that by Example 7.3 we have $\text{OE}_g^k \geq 4(g-1)$. And by Theorem 1.4, we know all cases with $|G| > 4(g-1)$. Then we reach Theorem 1.3.

Comment. We define two actions of a finite group G to be equivalent if the corresponding groups of homeomorphisms of (S^3, Σ_g) are conjugate (i.e., allowing isomorphisms of G). By the proof of Theorem 6.1 and the tables above, there are only finitely many types of actions of G on (S^3, Σ_g) such that $|G| > 4(g-1)$ and the handlebody orbifold bounded by Σ_g/G is not of type II. In particular there are only finitely many types of actions of G on (S^3, Σ_g) realizing OE_g for $g \neq 21, 481$.

7. See the maximum symmetries of Σ_g in S^3 for general g

Example 7.1. For every $g > 1$, we will construct a group G of order $4(g + 1)$ which acts on $S^3 = V_g \cup V'_g$, the standard Heegaard splitting of S^3 . Let P_{g+1} be the equator sphere S^2 of S^3 with $g + 1$ punctured holes, see Figure 20 for $g = 4$. We choose the holes all on the equator S^1 of S^2 , centered at the vertices of a regular $g + 1$ -polygon. There is a dihedral group D_{g+1} acting on (S^3, S^2) which keeps P_{g+1} invariant. And there is also a \mathbb{Z}_2 action on S^3 changing the inner and outer of S^2 , whose fixed point set is the equator of the 2-sphere in Figure 20. So there is a $D_{g+1} \times \mathbb{Z}_2$ action on P_{g+1} , therefore on Σ_g , the boundary of its invariant regular neighborhood V_g . This group has order $4(g + 1)$.

Figure 21 shows how the orbifold 15E is obtained from this action. Note the first branched covering of degree $2n$ is given by the action of $\mathbb{Z}_{g+1} \oplus \mathbb{Z}_2$ for $\mathbb{Z}_{g+1} \subset D_{g+1}$.

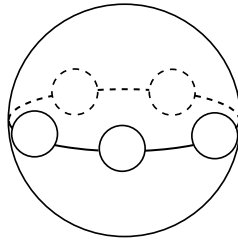

Figure 20

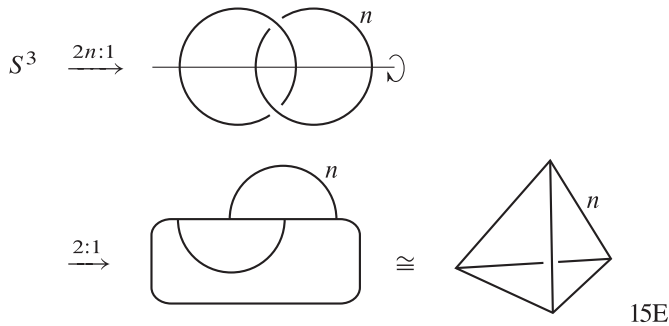

Figure 21

Example 7.2. For each $g = k^2 > 1$, we construct a group G of order $4(\sqrt{g} + 1)^2$ which acts on

$$S^3 = V_g \cup V'_g,$$

where G is a semidirect product

$$(\mathbb{Z}_{k+1} \times \mathbb{Z}_{k+1}) \rtimes_{\varphi} (\mathbb{Z}_2 \times \mathbb{Z}_2).$$

Writing

$$\begin{aligned} \mathbb{Z}_{k+1} \times \mathbb{Z}_{k+1} &= \langle x, y \mid xy = yx, x^{k+1} = y^{k+1} = 1 \rangle, \\ \mathbb{Z}_2 \times \mathbb{Z}_2 &= \langle s, t \mid st = ts, s^2 = t^2 = 1 \rangle, \end{aligned}$$

the semidirect product is given by

$$\varphi: sxs^{-1} = y, sy s^{-1} = x, txt^{-1} = x^{-1}, tyt^{-1} = y^{-1}.$$

Consider S^3 as the unit sphere in \mathbb{C}^2

$$S^3 = \{(z_1, z_2) \in \mathbb{C}^2 \mid |z_1|^2 + |z_2|^2 = 1\},$$

and let

$$a_j = (e^{\frac{2j\pi i}{k+1}}, 0), \quad b_j = (0, e^{\frac{2j\pi i}{k+1}}), \quad j = 0, 1, \dots, k.$$

Then the G -action on S^3 is given by

$$\begin{aligned} x: (z_1, z_2) &\longmapsto (e^{\frac{2\pi i}{k+1}} z_1, z_2), \\ y: (z_1, z_2) &\longmapsto (z_1, e^{\frac{2\pi i}{k+1}} z_2), \\ s: (z_1, z_2) &\longmapsto (z_2, z_1), \\ t: (z_1, z_2) &\longmapsto (\overline{z_1}, \overline{z_2}). \end{aligned}$$

It is easy to check this is a faithful orientation-preserving action.

Notice that this G -action keeps the set $\{a_i, b_j\}, i, j = 0, 1, \dots, k$, invariant. If we join each a_i and b_j by a geodesic in S^3 , we get a complete bipartite graph $\Gamma \subset S^3$ with $2k+2$ vertices and $(k+1)^2$ edges. Hence $\chi(\Gamma) = -k^2 + 1$. Hence the G -action maps Γ to itself, and induces an action on $\Sigma_g = \partial V_g$, V_g is an invariant neighborhood of Γ in S^3 with $k^2 = g$. Figure 22 gives the picture for $g = 4$. This gives an extendable group action of order $4(\sqrt{g} + 1)^2$, corresponding to orbifold 19 in the list of Theorem 6.1.

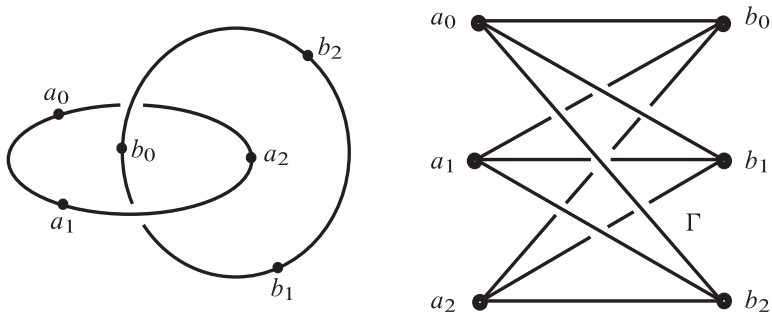

Figure 22

Figure 23 shows how the orbifold 19 be obtained from this action.

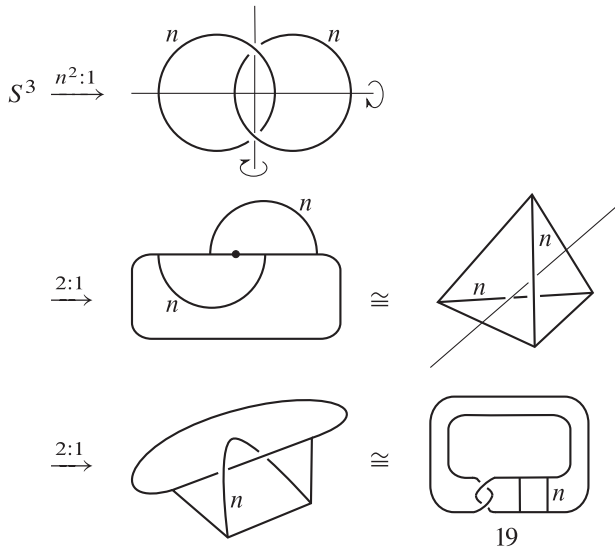

Figure 23

Example 7.3. Denote the graph in Figure 24 by $C_{g-1} \subset S^3$, where $g = 4$ and “ K ” is the connected sum of a knot “ k ” $\subset S^3$ and its π -rotation. Imitate the argument of Example 7.1, we can see that there is a $(D_{g-1} \oplus \mathbb{Z}_2)$ -action on (S^3, C_{g-1}) , therefore on $\Sigma_g = \partial V_g$ for an invariant regular neighborhood of C_{g-1} . And $\Sigma_g \subset S^3$ is knotted if k is knotted. Figure 25 gives its orbifold. The blue lines with knots in Figures 24 and 25 are dashed lines in previous sections and their preimages.

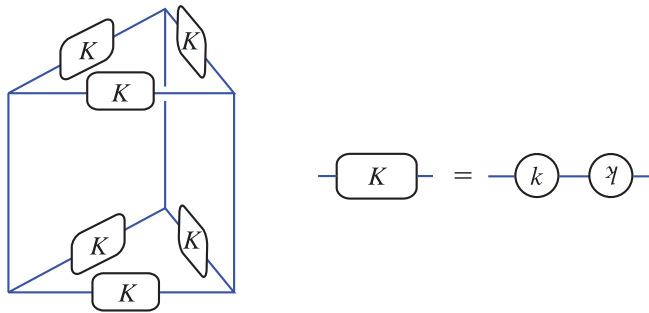

Figure 24

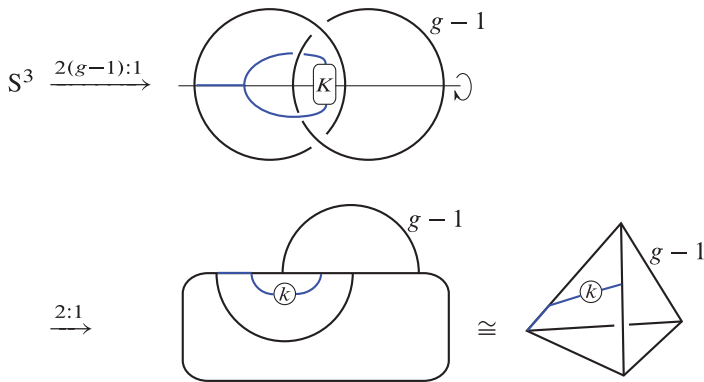

Figure 25

Example 7.4. Figure 27 shows a knotted handlebody of genus $g = 11$ which is invariant under a group action of order 120 of S^3 , corresponding to edge c in 34 (Table VI). All points are colored by their distance from the origin.

The group is isomorphic to $A_5 \times \mathbb{Z}_2$, where we consider the alternating group A_5 as the orientation preserving symmetry group of the 4-dimensional regular Euclidean simplex, and \mathbb{Z}_2 is generated by $-\text{id}$ on E^4 . Let the 4-simplex be centered at the origin of E^4 and inscribed in the unit sphere S^3 . The radial projection of its boundary to S^3 gives a tessellation of S^3 by 5 tetrahedra invariant under the action of A_5 . We present one of these tetrahedron in Figure 26.

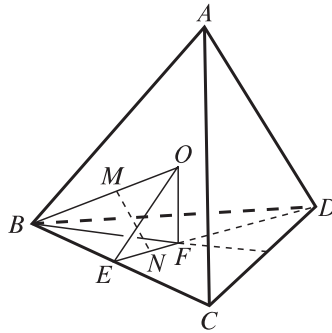

Figure 26

Imagine the figure has spherical geometry. O is the center of the tetrahedron, F is the center of triangle $\triangle BCD$, E is the middle points of BC , M is the middle points of BO , N is the middle points of EF . The orbit of the geodesic MN under the group action of A_5 joins to a graph in S^3 ; note that this graph is invariant also under $-id$ on S^3 . Projecting to E^3 , Figure 27 shows this graph and the boundary surface of the regular neighborhood of the projected image (by [14]).

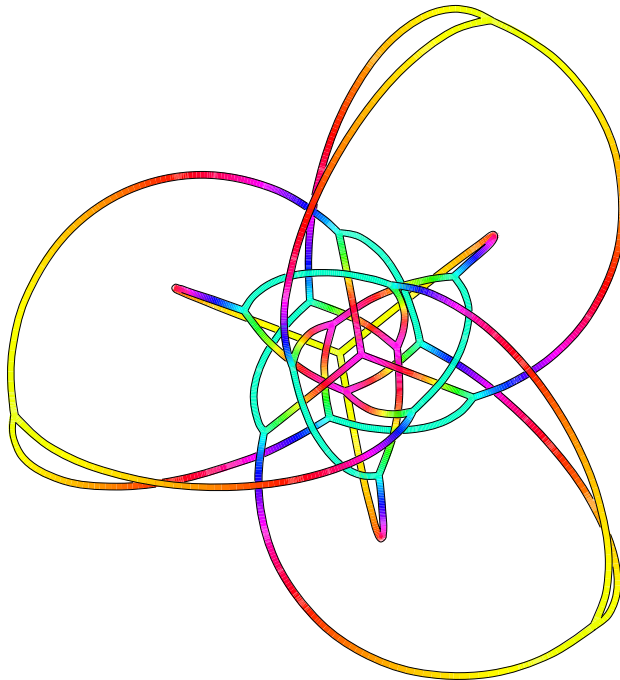

Figure 27

References

- [1] M. Boileau, S. Maillot, and J. Porti, *Three-dimensional orbifolds and their geometric structures*. Panoramas et Synthèses, 15. Société Mathématique de France, Paris, 2003. [Zbl 1058.57009](#) [MR 2060653](#)
- [2] G. Burde and H. Zieschang, *Knots*. De Gruyter Studies in Mathematics 5. Walter de Gruyter & Co., Berlin 1985. [Zbl 0568.57001](#) [MR 0808776](#)
- [3] W. D. Dunbar, Geometric orbifolds. *Rev. Mat. Univ. Complut. Madrid* **1** (1988), no. 1-3, 67–99. [Zbl 0655.57008](#) [MR 0977042](#)
- [4] W. D. Dunbar, Nonfibering spherical 3-orbifolds. *Trans. Amer. Math. Soc.* **341** (1994), no. 1, 121–142. [Zbl 0808.57007](#) [MR 1118824](#)
- [5] A. Hurwitz, Über algebraische Gebilde mit eindeutigen Transformationen in sich. *Math. Ann.* **41** (1892), no. 3, 403–442. [JFM 24.0380.02](#) [MR 1510753](#)
- [6] D. McCullough, A. Miller, and B. Zimmermann, Group actions on handlebodies. *Proc. London Math. Soc.* (3) **59** (1989), no. 2, 373–416. [Zbl 0638.57017](#) [MR 1004434](#)
- [7] W. H. Meeks and S. T. Yau, The equivariant Dehn’s lemma and loop theorem. *Comment. Math. Helv.* **56** (1981), no. 2, 225–239. [Zbl 0469.57005](#) [MR 0630952](#)
- [8] J. Rotman, *An introduction to the theory of groups*. 4th ed. Graduate Texts in Mathematics, 148. Springer, New York, 1995. [Zbl 0810.20001](#) [MR 1307623](#)
- [9] W. P. Thurston, *The geometry and topology of three-manifolds*. Lecture Notes. Princeton University, Princeton, 1978. <http://library.msri.org/books/gt3m/PDF/1.pdf>
- [10] C. Wang, S. C. Wang, Y. M. Zhang, and B. Zimmermann, Extending finite group actions on surfaces over S^3 . *Topology Appl.* **160** (2013), no. 16, 2088–2103. [MR 3106463](#) [Zbl 1286.57018](#)
- [11] C. Wang, S. C. Wang, Y. M. Zhang, and B. Zimmermann, Embedding surfaces into S^3 with maximum symmetry. Preprint 2012. [arXiv:1209.1170v2](https://arxiv.org/abs/1209.1170v2) [math.GT]
- [12] B. Zimmermann, *Über Homöomorphismen n -dimensionaler Henkelkörper und endliche Erweiterungen von Schottky-Gruppen*, *Comment. Math. Helv.* **56** (1981), 474–486.
- [13] The GAP Group, *GAP – Groups, Algorithms, and Programming*. Version 4.4.12, 2008. www.gap-system.org
- [14] Wolfram Research, Inc., *Mathematica*, Version 6.0, Champaign, IL (2007).

Chao Wang, School of Mathematical Sciences, Peking University,
Beijing, 100871 P. R. China

e-mail: chao_wang_1987@126.com

Shicheng Wang, School of Mathematical Sciences, Peking University,
Beijing, 100871 P. R. China

e-mail: wangsc@math.pku.edu.cn

Yimu Zhang, School of Mathematical Sciences, Peking University,
Beijing, 100871 P. R. China

e-mail: zym534685421@126.com

Bruno Zimmermann, Università degli Studi di Trieste,
Dipartimento di Matematica e Geoscienze, via Alfonso Valerio 12/1,
34100 Trieste, Italy

e-mail: zimmer@units.it